



CRE100HTP

Smart Fan

Installation and Maintenance



1.0 SAFETY INFORMATION

- The installation must be completed by competent persons in accordance with good industry practice and should conform to all governing and statutory bodies i.e. IEE, CIBSE, HVCA, etc.
- If the environment in which the product is installed also houses a fuel-operating device (water heater, methane stove etc. that is not a “sealed chamber” type), it is essential to ensure adequate air intake, to ensure good combustion and proper equipment operation.
- Ensure adequate air return into the room in compliance with existing regulations in order to ensure proper device operation. Ensure the fans capability by checking the performance fan curve. Flexible ducting is not recommended.
- Disconnection from the supply mains must be incorporated within the fixed wiring in accordance with the wiring regulations and shall have a minimum contact separation of 3mm in accordance with the latest edition of the IEE Wiring Regulations.
- In case of window installation it is necessary to use the appropriate window kit, which is not included. Glass thickness from 11mm to 35mm.
- This appliance can be used by children aged from 8 years and above and persons with reduced physical, sensory or mental capabilities or lack of experience and knowledge if they have been given supervision or instruction concerning use of the appliance in a safe way and understand the hazards involved. Cleaning and user maintenance should not be made by children without supervision. The unit is not intended for use by persons (including children) with reduced physical, sensory or mental capacities or those with a lack of experience and knowledge, unless they have been given supervision or instruction concerning use of the unit from a person responsible for their safety. Children should be supervised to ensure that they do not play with the unit.

2.0 INTRODUCTION

These high quality extractor fans are mechanical ventilation units designed to ensure air extraction in small / medium sized rooms. The units are suitable for air discharge directly to the outside or in the presence of short ducted system.

Please read these instructions carefully **before** installing the fan unit. Failure to comply with these instructions could reduce both the life and performance of the product and may invalidate the warranty. Kair assume no responsibility for damage to persons or property resulting from failure to observe the regulations contained in this booklet.

This appliance can be used by children aged from 8 years and above and persons with reduced physical, sensory or mental capabilities or lack of experience and knowledge if they have been given supervision or instruction concerning use of the appliance in a safe way and understand the hazards involved. Cleaning and user maintenance should not be made by children without supervision. The unit is not intended for use by persons (including children) with reduced physical, sensory or mental capacities or those with a lack of experience and knowledge, unless they have been given supervision or instruction concerning use of the unit from a person responsible for their safety. Children should be supervised to ensure that they do not play with the unit.

2.1 Unit Features

- Construction Material: High quality, impact and UV-resistant ABS.
- Unit fascia is removable for cleaning without the use of tools.
- Single phase DC brushless motor with locked rotor protection.
- Motor mounted on high quality ball bearings.
- The fan is double insulated: no earth connection is required.
- Trickle speed selectable: 4, 6, 8, 10, 13 l/s or off.
- Option to boost through a Switch Live (SL) connection or pull cord. Boost speed selectable: 8, 13, 15, 18, 20 or 25 l/s.
- Three button, three digit 7 segment LED display, for configuration
- Installation type selection available (through wall or ducted).
- Timer and integral humidistat.
- Constant volume facility.
- IPX4 rating with wall installation.
- Power supply 220V to 240V~ 50/60Hz.
- Operating temperature: 0°C to +40°C
- Filterless

2.2 Code Descriptions

CODE	DESCRIPTION
CRE100HTP	230V Continuous Mixed Flow Extract Fan
CRE100HTP	230V Decentralised Mechanical Extract Ventilation fan (dMEV) – see Section 6.11
CRE100-WINKIT	Window Kit for CRE Units
CRE100-WP	Wall Plate for CRE Units

3.0 DIMENSIONS

Figure 1. Unit Dimensions

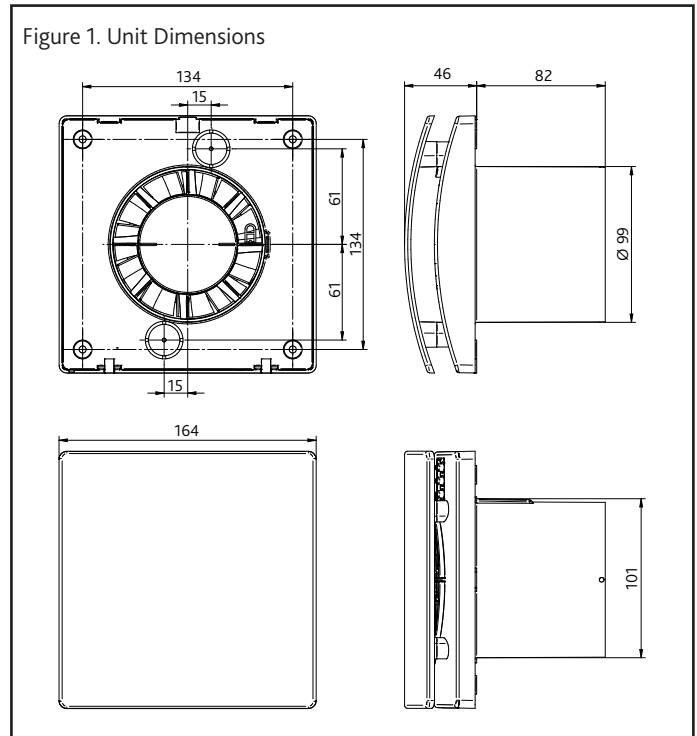

Installation and Maintenance

4.0 INSTALLATION

Before commencing any work read the following instructions carefully and ensure you have the necessary competency to complete the work safely.

The installation must be completed by competent persons in accordance with good industry practice and should conform to all governing and statutory bodies i.e. IEE, CIBSE, HVCA, etc.

If the environment in which the product is installed also houses a fuel-operating device (water heater, methane stove etc., that is not a "sealed chamber" type), it is essential to ensure adequate air intake, to ensure good combustion and proper equipment operation.

Ensure adequate air return into the room in compliance with existing regulations in order to ensure proper device operation. Ensure the fans capability by checking the performance fan curve. Flexible ducting is not recommended.

Ensure that the fan or exhaust grille are not obstructed, to guarantee optimum air passage.

4.1 Wall Installation

1. Select a suitable position for the fan that keeps the duct as short and as straight as possible (ideally on a wall within 400mm of the ceiling).
2. Cut a hole in the wall to suit the outside diameter of the ducting or wall-liner. Install the duct or wall-liner taking care to seal at both ends between it and the wall using proprietary waterproof mastic.
3. Remove the magnetic fascia of the fan by pulling the fascia straight off.
4. Loosen the front fan plate by unscrewing the front fixing screws (Figure 2).
5. Use a small flat-head screwdriver to release the retaining clips between the front fan plate and fan backplate. Remove front fan plate (Figure 3).
6. Position the fan in the duct and mark the four retaining screw positions through the fan backplate. Fit screw anchors suitable for the wall construction.
7. If installing via recessed cable entry, drill a hole of sufficient diameter in the fan backplate to fit the rubber grommet and allow the supply cable to pass through the backplate (Figure 4).
8. Screw the backplate to the wall in positions marked earlier.
9. For surface cable entry remove the white rubber cable gland (Figure 5) and cable clamp from the backplate, cut the cable gland to the required diameter and thread the supply cable through the gland. Slot the gland into place in the fan backplate.
10. For recessed cable entry, fit the rubber grommet into the hole drilled in step 7 and thread the supply cable through the grommet.
11. Complete the wiring by following the relevant wiring diagram in section 5.0. Ensure that the cable gland is slotted into place in the backplate, for surface cable entry the cable is to be secured via the cable clamp (Figure 6 & Figure 7).
12. Replace the front fan plate, an audible "Click" should be heard when the front cover clips into place. Fix with the screws provided, and replace the fascia.

4.2 Window Installation

See additional installation instructions provided with optional window kit.

Figure 2. Unscrewing front fixing screws.

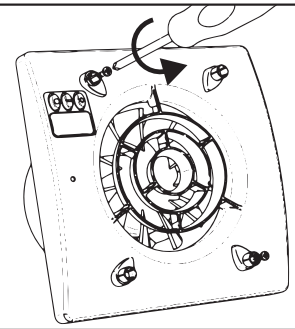

Figure 3. Releasing retaining clips with flat-head screwdriver.

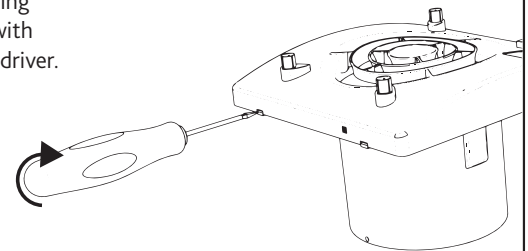

Figure 4. Drilling fan backplate for recessed cable entry.

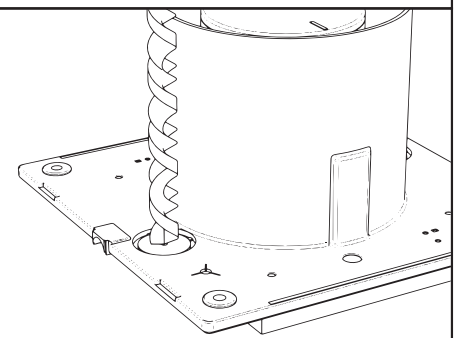

Figure 5. Removing cable gland for surface cable entry.

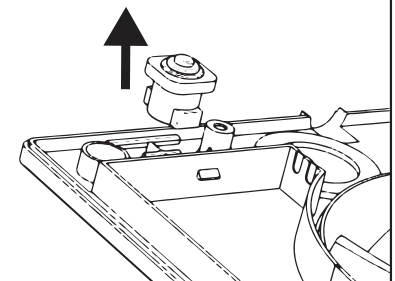

Figure 6. Cable installation for surface cable entry.

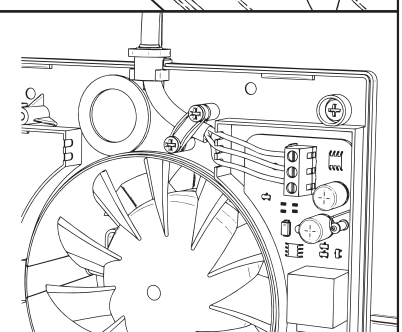
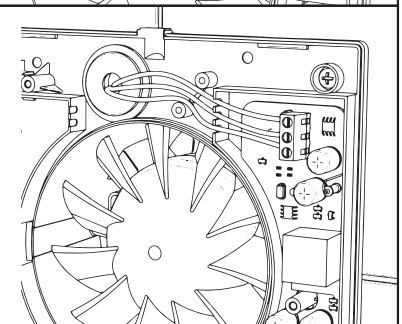

Figure 7. Cable installation for recessed cable entry.



5.0 WIRING

IMPORTANT

Isolation: Before commencing work, ensure the unit, switched live and any controls are electrically isolated from the electric supply.

IMPORTANT

Do not over tighten terminal block screws, maximum torque 0.15Nm

Disconnection from the supply mains must be incorporated within the fixed wiring in accordance with the wiring regulations and shall have a minimum contact separation of 3mm in accordance with the latest edition of the IEE Wiring Regulations.

Before connecting the product to the power supply or the power outlet, ensure that:

- The data plate (voltage and frequency) correspond to those of the electrical mains.
- The electrical power supply/socket is adequate for maximum unit power. If not, contact a qualified technician.

The electrical system to which the unit is connected must comply with regulations.

IMPORTANT

When wiring to the PCB terminals, do not overtighten the screws.

5.1 CRE100HTP

Figure 8. Unit Wiring

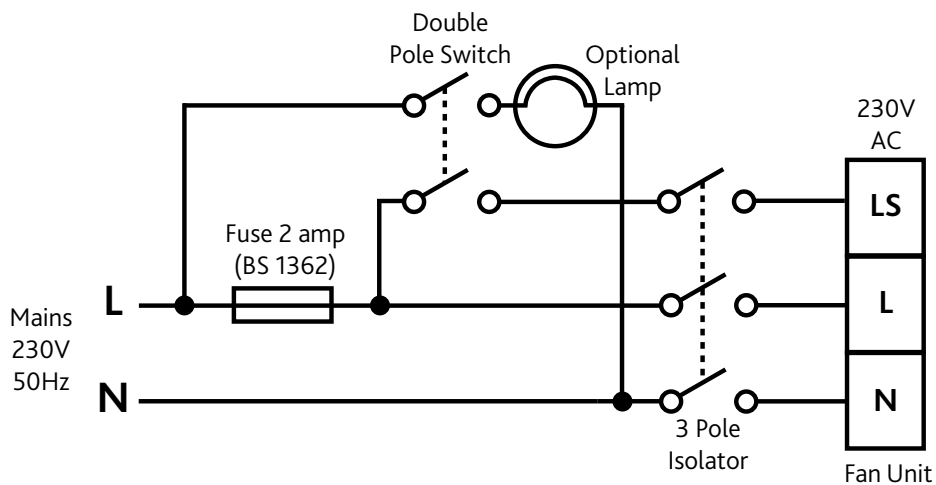

Installation and Maintenance

6.0 OPERATION

Read this manual carefully before operating the product and keep it in a safe place for reference.

The unit is provided with a 7 segment LED display which is visible by removing the fascia. The LED display illuminates upon pressing any button, and stays on for 10 seconds after the last button press.

IMPORTANT

Additional Safety Feature: When the front cover support is removed, the impeller stops turning. To aid with installation, this feature is disabled for the first 60 minutes of operation.

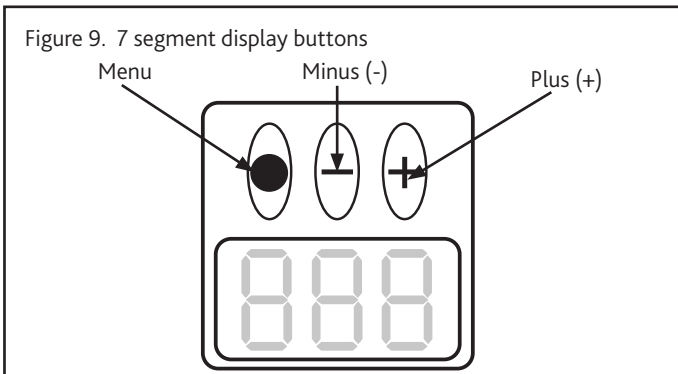

6.1 Description of Operation

Upon power-up, the unit works at 'trickle' speed ('A').

If humidistat is activated, the unit works at 'comfort boost' speed ('b').

If the SL or pull-cord is activated, the unit runs at 'boost' speed ('B').

After the pull cord switch is turned off, the fan continues to run at 'boost' speed for a settable period of time, then it returns to selected 'trickle' speed (or to 'comfort boost' speed in case automatic humidistat operation is on). The front cover LED illuminates to indicate when the pull cord switch is on.

The run-on timer function is activated only if the SL has been on for at least 3 minutes. This function does not activate with use of the pull cord.

6.2 Run Hours Monitor

An integral run time monitor is included with the unit. Upon power-up the display shows the running hours counter in a user friendly format.

E.g. 000 -> 000 (1 year) -> 004 (4 months) -> 006 (6 days) -> 003 (13 hours) -> 000...

Note that due to the format of a 7 segment display 'm' cannot be used for months with 0 being displayed in its place.

6.3 Unit of Measure

All air volumes shown on the unit for trickle, comfort boost and boost and in litres per second (l/s), this is displayed on the unit as a lower case 'u' (u).

Unit of Measure (u)	
Setting	Value Displayed
l/s (Default)	LS

6.4 Trickle Speed

Upon power up and in the absence of an active SL or pull cord, the unit will run continuously at a settable trickle speed of between 0-13 l/s.

6.4.1 Setting Trickle Speed

Select the trickle speed setting on the unit by pressing the menu button until the first digit on the 7 segment display shows an upper case 'A' (A).

Press '+' or '-' to raise and lower the trickle speed between the values given in the table below.

Trickle Speed (A)	
Setting (l/s)	Value Displayed
0	00
4 (Default)	04
6	06
8	08
10	10
13	13

6.5 Comfort Boost Speed

The unit will run at a settable comfort boost speed of between 6-25 l/s when either of the below conditions have been met.

- The humidistat has been activated.
- The run-on timer has been activated.

6.5.1 Setting Comfort Boost Speed

Select the comfort boost speed setting on the unit by pressing the menu button until the first digit on the 7 segment display shows an lower case 'b' (b).

Press '+' or '-' to raise and lower the comfort boost speed between the values given in the table below.

Comfort Boost (b)	
Setting (l/s)	Value Displayed
6	06
8	08
10	10
13 (Default)	13
15	15
18	18
20	20
25*	25

* 25 l/s is only available when through the wall installation is selected (see section 6.8).

6.6 Boost Speed

The unit will run at a settable boost speed of between 8-25 l/s when either of the below conditions have been met.

- The SL (Switched Live) has been activated.
- The pull cord has been activated.

6.6.1 Setting Boost Speed

Select the boost speed setting on the unit by pressing the menu button until the first digit on the 7 segment display shows an upper case 'B' (B).

Press '+' or '-' to raise and lower the boost speed between the values given in the table below.

Boost (H)	
Setting (l/s)	Value Displayed
8	08
13	13
15	15
18	18
20	20
25* (Default)	25

* 25 l/s is only available when through the wall installation is selected (see section 6.8).

6.7 Constant Flow Operation

The unit can run at a constant speed.

6.7.1 Choosing Constant Flow

Select constant flow on the unit by pressing the menu button until the first digit on the 7 segment display shows a lower case 'c' (C).

Press + or - to raise and select the appropriate installation type as given in the table below.

Constant Flow (C)	
Setting	Value Displayed
Off (Default)	0C
On	1C

6.8 Installation Type

The unit will scale its speed to obtain the air flow rates given for the trickle, comfort boost and boost speeds based on installation type.

'Through Wall' installation is typically for fans that are mounted on an external wall / window and extract direct to the outside.

An 'In Room' installation is typically for fans that are mounted on the ceiling or internal wall and which are ducted to the outside. Note, that the unit will run at a higher RPM when an 'In Room' installation is selected.

6.8.1 Setting Installation Type

Select the installation type on the unit by pressing the menu button until the first digit on the 7 segment display shows an upper case 'I' (I).

Press + or - to raise and select the appropriate installation type as given in the table below.

Installation Type (I)	
Setting	Value Displayed
Through Wall (Default)	1I
In Room - Ducted	2I

6.9 Humidity

An integral humidistat is included with the unit and has an adjustable threshold of 65-95%. If the humidistat is activated, the unit runs at comfort boost speed and continues running for a fixed 5 minute run-on cycle after humidity levels drop below the selected threshold.

In AUTO mode, the humidistat triggers if there's a steep humidity variation and humidity is over 65%.

6.9.1 Setting the Humidistat

Select the humidistat setting on the unit by pressing the menu button until the first digit on the 7 segment display shows a lower case 'h' (H).

Press the '+' or '-' to raise and lower the humidistat threshold between the values given in the table below.

Humidistat Threshold (H)	
Setting	Value Displayed
AUTO (Default)	8H
65%	65
75%	75
85%	85
95%	95
OFF	0H

6.10 Run-on Timer

An integral run-on timer is included with the unit which is easily adjustable between 1-25 minutes. When the SL is deactivated, the unit runs at comfort boost speed and continues running for a fixed time run-on cycle according to the setting of the run-on timer.

After the run-on time has expired, the unit returns to trickle speed.

If the SL does not stay active for 3 minutes run-on is not performed.

In AUTO mode the run-on timer works automatically according to the user's habits with the run-on time increasing depending on how long the SL is active. The principles behind this mode of operation are described below.

- If SL is active for under 3 minutes, the unit does not run-on.
- If SL is active for between 3-10 minutes, the unit runs-on for 5 minutes.
- If SL is active for between 10-20 minutes, the unit runs-on for 10 minutes.
- If SL is active for over 20 minutes, the unit runs-on for 15 minutes.

6.10.1 Setting the Run-on Time

Select the run-on time setting on the unit by pressing the menu button until the first digit on the 7 segment display shows a lower case 't' (T).

Press '+' or '-' to raise and lower the run-on time between the values given in the table below.

Run-On Timer (T)	
Setting (minutes)	Value Displayed
AUTO (Default)	8T
1	01
5	05
10	10
15	15
20	20
25	25
OFF	0T

Installation and Maintenance

6.11 Decentralised Mechanical Extract Ventilation (dMEV)

These units are suitable for decentralised mechanical extract ventilation and are recognised by the Government's Standard Assessment Procedure (SAP) under the Product Characteristic Database (PCDB).

In order to meet requirements, the unit must be set to the below specifications:

- Run continuously (see Section 6.4) at 4, 6 or 8l/s, depending on the requirements under Part F of the building regulation, Table 5.1a.
- Boost speed (see Section 6.6) should be set at 6, 8 or 13 l/s, again see Building Regulation Part F Table 5.1a.
- Comfort Boost (see Section 6.5) should be set between trickle speed and boost speed settings .
- Constant Flow – ON (see Section 6.7).
- Through Wall or In-Room (ducted) installation (see Section 6.8).
- All other settings are as per customers' requirements.

7.0 MAINTENANCE

Before any maintenance or cleaning operation, switch off the fan and disconnect from the power supply.

The magnetic front cover can be removed and cleaned with water and a mild detergent using a soft cloth and the motor fan assembly can be cleaned with a dry brush or dry cloth. Any other maintenance or cleaning should be carried out by properly qualified personnel.

Ensure the unit does not come into contact with any kind of liquid or solvent. If this should occur, contact a qualified technician before reassembling the fan.

NOTE: The motor does not require lubrication as it is of the maintenance free "sealed for life" type.

8.0 WARRANTY

The 5 year warranty starts from the day of delivery and includes parts and labour for the first year. The remaining period covers replacement parts only.

This warranty is void if the equipment is modified without authorisation, is incorrectly applied, misused, disassembled, or not installed, commissioned and maintained in accordance with the details contained in this manual and general good practice.

The product warranty applies to the UK mainland and in accordance with our Conditions of Sale.

If any abnormalities in operation are detected, disconnect the unit from the supply and contact a qualified technician immediately. Use original spare parts only for repairs.

If the supply cord is damaged, it must be replaced by the manufacturer, its service agent or similarly qualified persons in order to avoid a hazard.

9.0 DISPOSAL AND RECYCLING

Information on disposal of units at the end of life.

This product complies with EU Directive 2002/96/EC.

The symbol of the crossed-out dustbin indicates that this product must be collected separately from other waste at the end of its life. The user must, therefore, dispose of the product in question at suitable electronic and electro-technical waste disposal collection centres, or else send the product back to the retailer when purchasing a new, equivalent type unit.



Separate collection of decommissioned equipment for recycling, treatment and environmentally compatible disposal helps to prevent negative effects on the environment and on health and promotes the recycling of the materials that make up the equipment.

Improper disposal of the product by the user may result in administrative sanctions as provided by law.

10.0 AFTER SALES ENQUIRIES

For technical assistance or further product information, including spare parts and replacement components, please contact the After Sales Department.

Telephone 08451 66 22 40
aftersales@kair.co.uk

Technical or commercial considerations may, from time to time, make it necessary to alter the design, performance and dimensions of equipment and the right is reserved to make such changes without prior notice.