

# Unity CV2GIP / CV2SVGIP

## Decentralised Mechanical Extract Ventilation (dMEV) User / Homeowner Guide

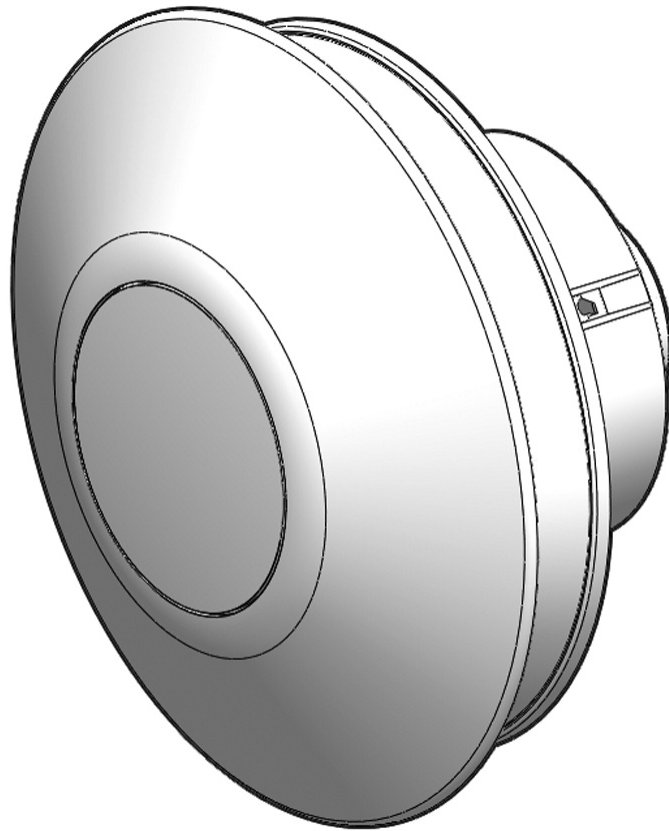

### **Commissioning and Inspection Record:**

Located on page 10 of this guide, should have been completed  
by the Commissioning Engineer.

# Contents

<b>User / Homeowner Information</b>	<b>Page</b>
1. Ventilation in Your Home	3
2. General Overview	4
3. Homeowner Controls	6
4. Servicing / Maintenance	10
5. Commissioning & Inspection Record	10

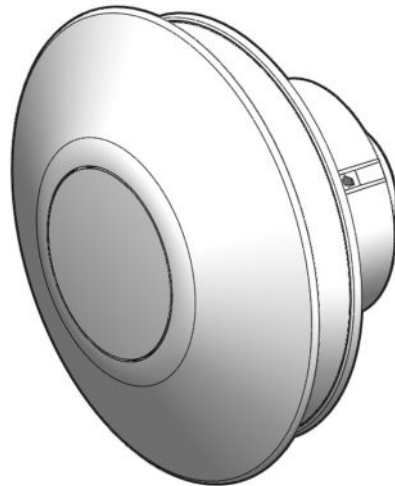

To disassemble the unit, disconnect from mains supply and use a screwdriver to segregate the electronic components and motor from the plastic housing. Dispose items in accordance with WEEE.

## **WEEE Statement**

This product may not be treated as household waste. Instead it should be handed to an appropriate collection point for the recycling of electrical and electronic equipment.

For more detailed information about the recycling of this product, please contact your local council office or your household waste disposal service.



# 1.0 Ventilation In Your Home

Your home has continuously running ventilation Unity CV2GIP / CV2SVGIP (dMEV) fans installed. This consists of locally sited extract fans that form part of a whole house ventilation approach. These fans extract air on a continual basis from the following areas (defined as wet rooms within Building Regulations) in residential dwellings –

- Kitchen
- Bathroom
- Utility Room
- WC/Cloakroom
- Ensuite Bath/Shower Room

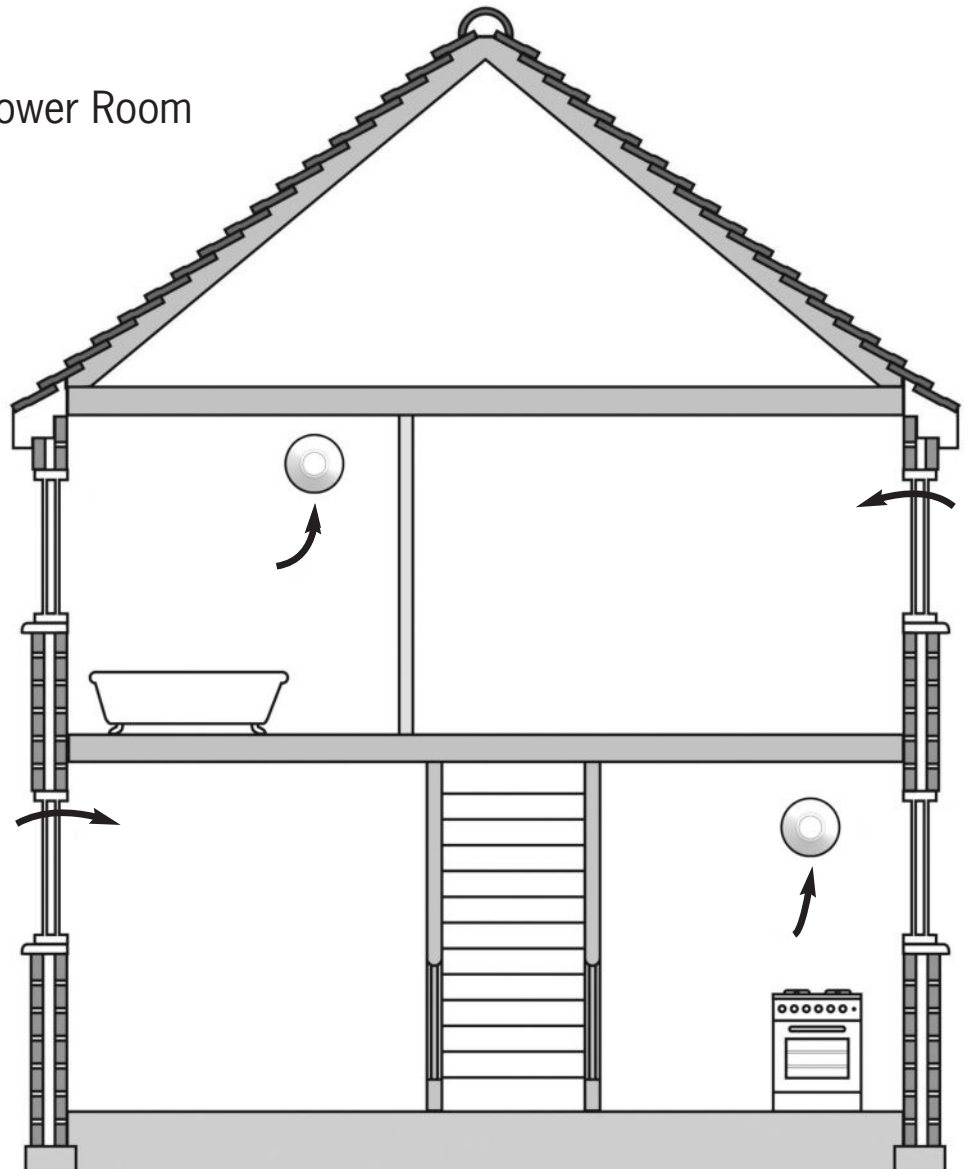

## 2.0 General Overview

2.1.1 The specific operation of your fan may vary depending on the way it has been installed.

The options are –

Trickle Speed: Operating on a continual basis.

Boost Speed: Activated manually using our GS2 switch or via the room light switch.

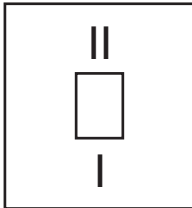

GS2 switch markings - Trickle (I) & Boost (II)  
Operation

**Note:** Other manufacturers switches may show different markings.

2.1.2 To maintain a healthy indoor environment the Unity CV2GIP / CV2SVGIP includes SMART technology for Over-run Timer (Greenwood TimerSMART™) and Humidity (Greenwood HumidiSMART™).

2.1.3 **Greenwood TimerSMART™** monitors the length of time that there is an occupancy presence within a wet room (via the 'switch-live') and provides a fixed over-run time period to best match the length of time that the 'switch live' is active (as shown below):

**Note:** The first 5 minutes will not activate an over-run.

Time 'Switch Live' is Active	Over-run Boost Period
0 – 5 minutes	No over-run
5 – 10 minutes	5 minutes
10 – 15 minutes	10 minutes
15+ minutes	15 minutes

This removes nuisance running noise and unnecessary energy wastage typically associated with traditional timers.

- 2.1.4 **Greenwood HumidiSMART™** monitors the ambient humidity within the wet room environment and looks for short peaks of humidity made by either showering or bathing. This smart technology ensures that your Unity CV2GIP / CV2SVGIP is not on boost for prolonged periods of time, removing nuisance running noise and unnecessary energy wastage typically associated with increases to background humidity which naturally occurs with the changing seasons.
- 2.1.5 To maintain good indoor air quality within the dwelling it is important that the fan remains in operation at all times unless switched off for maintenance. (See section 4.0 Servicing / Maintenance).
- 2.1.6 Depending on when your home was built, background window trickle ventilators may be provided in dry habitable rooms. **Trickle vents should not be installed in the same rooms as the fan, as overall ventilation effectiveness can be reduced.**
- 2.1.7 **Warning:** This appliance can be used by children aged from 8 years and above and persons with reduced physical, sensory or mental capabilities or lack of experience and knowledge if they have been given supervision or instruction concerning use of the appliance in a safe way and understand the hazards involved. Children shall not play with the appliance.
- 2.1.8 Where an open-flued oil or gas-fuelled appliance is installed precaution must be taken to avoid a back-flow of gases into the room.
- 2.1.9 The CV2SVGIP fan must only be installed by using the supplied Safety Extra Low Voltage (SELV) controller corresponding to the markings on the appliance.
- 2.1.10 Cleaning and user maintenance shall not be made by children without supervision.
- 2.1.11 Always isolate fan from mains supply before cleaning. Do not use solvents to clean this fan.

# 3.0 Homeowner Controls

## 3.1.1 Controls

This section shows how to operate the Unity CV2GIP / CV2SVGIP control panel.

## 3.1.2 Control Panel

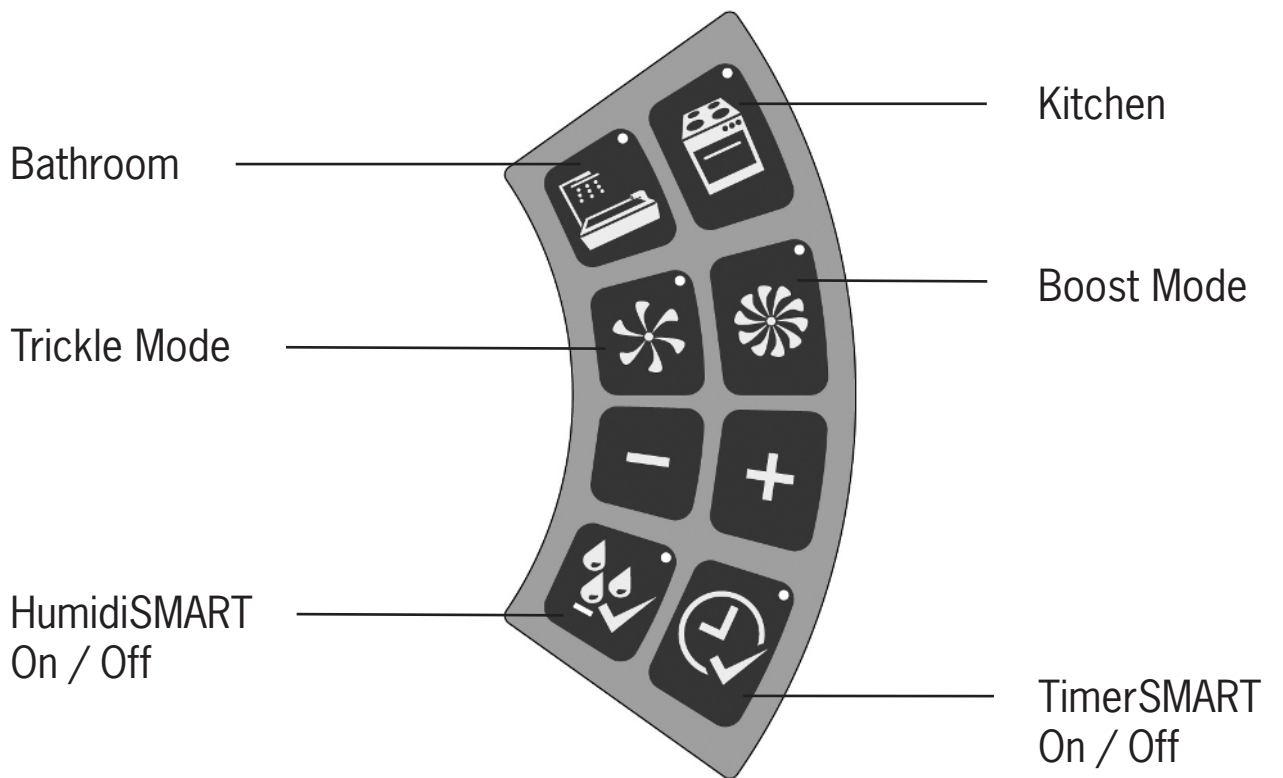

### 3.1.3 To View Fan Set Up / Status

Press any button to activate the panel. The current fan set up / status will be shown via the green lights.

Example shows: Bathroom setting selected  
Boost mode activated  
HumidiSMART feature selected

**Note:** The Unity CV2GIP / CV2SVGIP is commissioned during installation to provide the correct airflow requirements for your dwelling. Post adjustment of the room setting or airflow speeds is not available.



### 3.1.4 To Change the HumidiSMART Setting

The HumidiSMART monitors the humidity of the extracted air at all times. A rapid rise in humidity from a bath / shower, should be picked up by the sensor and should cause the fan to automatically switch to Boost mode.

When humidity falls below a calculated threshold close to background levels, the fan should return to trickle mode.

To identify current fan status, press any button to activate the panel. Upon identification of control status, either press [  ] to activate or deactivate the HumidiSMART. Please note the light should come on to indicate that the function is active.

Factory set to OFF

Option's ON / OFF

**Note:** After approximately 10 seconds of inactivity, the control panel lights should turn off and save selection settings.

**Note:** This feature can be activated at the same time as the TimerSMART.





### 3.1.5 To Change the TimerSMART Setting

The TimerSMART monitors the length of time the unit has been in boost mode via the Switch Live. Once the Switch Live is deactivated the TimerSMART over-run period should continue to run the unit for a calculated time if required.

**Note:** The first 5 minutes should not activate an over-run.

Time 'Switch Live' is Active	Over-run Boost Period
0 – 5 minutes	No over-run
5 – 10 minutes	5 minutes
10 – 15 minutes	10 minutes
15+ minutes	15 minutes

To identify current fan status, press any button to activate the panel. Upon identification of control status, either press [] to activate or deactivate the TimerSMART. Please note the light should come on to indicate that the function is active.

Factory set to OFF

Option's ON / OFF

**Note:** After approximately 10 seconds of inactivity, the control panel lights should turn off and save selection settings.

**Note:** This feature can be activated at the same time as the HumidiSMART.



## 4.0 Servicing / Maintenance

- 4.1.1 The Unity CV2GIP / CV2SVGIP contains a unique backward curved mixed flow impellor that has been designed to reduce against any build up of dirt. **The fan motor has sealed for life bearings, which do not require lubrication.**
- 4.1.2 Periodic cleaning of the fans front cover and casing can be carried out using a soft damp cloth. Care must be taken when wiping around the control panel.
- 4.1.3 **Warning:** The Unity CV2GIP / CV2SVGIP must be isolated from the mains supply before removing the electronics cover. Do not use solvents to clean this fan.
- 4.1.4 Cleaning and user maintenance shall not be made by children without supervision.
- 4.1.5 Please note that your stored fan settings will not be lost during any interruptions to your fan's power supply.

## 5.0 Commissioning & Inspection Record

- 5.1.1 This section should be used to record all installation details. The Commissioning Engineer should use the following Parts 1 to 3, to record important information relating to the installation, of which, should be incorporated into the Home Information Pack for the homeowner to keep.
- **Part 1** – **System details and declarations**
  - **Part 2a** – **Installation details**
  - **Part 2b** – **Inspection of installation**
  - **Part 3** – **Air flow measurement test and commissioning details**

## Part 1 – System details and declarations

1.1 Installation Address Details	
Dwelling Name/Number	
Street	
Locality	
Town	
County	
Post Code	
1.2 Installation Details	
System Classification	System 3 – Decentralised Mechanical Extract Ventilation
Manufacturer	Zehnder Group UK Limited
Model Number	
Serial Number (where available)	
Location of dMEV fans	

## Part 2a – Installation details

2.1 Installation Checklist – General (all Systems)		Tick as appropriate	
Has the system been installed in accordance with manufacturer's requirements?		Yes	No
Have relevant system installation clauses been followed as detailed in Tables 1, 3, 5 and 7 as applicable?		Yes	No
Type of ductwork installed (e.g. rigid, semi-rigid)			
If any deviation from Tables 1, 3, 5 and 7, these should be detailed here.			
Description of installed controls (e.g. timer, central control, humidistat, PIR, etc)			
Location of manual / override controls			

2.2 Installation Engineer's Details	
Name	
Company	
Address Line 1	
Address Line 2	
Telephone Number	
Post Code	
Signature	
Competent Person Scheme / Registration Number (if applicable)	
Date of Installation (completion)	

## Part 2b – Inspection of Installation

This section should be completed before completing part 3.

2.3 Visual Inspections – General (all Systems)	Tick as appropriate	
Total installed equivalent area of background ventilators in dwelling?		mm
Total floor area of dwelling?		m <sup>2</sup>
Does the total installed equivalent ventilator area meet the requirements given in Tables 5.2a, 5.2b, or 5.2c in ADF?	Yes	No
Have all background ventilators been left in the open position?	Yes	No
Have the correct number and location of extract fans/ terminals been installed that satisfy Table 5.2a in ADF?	Yes	No
Is the installation complete with no obvious defects present?	Yes	No
Do all internal doors have sufficient undercut to allow air transfer between rooms (i.e. 10 mm over and above final floor finish)?	Yes	No
Has all protection/packaging been removed (including from background ventilators) such that system is fully functional?	Yes	No
For ducted systems, has the ductwork installation been installed in such manner that air resistance and leakages kept to a minimum?	Yes	No
Are the correct number and size of background ventilators provided that satisfy ADF?	Yes	No
Has the entire system been installed such that there is sufficient access for routine maintenance and repair/replacement of components?	Yes	No
Upon initial start up, was any abnormal sound or vibration experienced, or unusual smells detected?	Yes	No

## 2.4 Inspector's Details

Name		
Company		
Address Line 1		
Address Line 2		
Telephone Number		
Post Code		Signature
Competent Person Scheme / Registration Number (if applicable)		
Date of Inspection (completion)		

## Part 3 – Air flow measurement test and commissioning details

### 3.1 Test Equipment

Schedule of air flow measurement equipment used, (model and serial)	Date of last UKAS calibration
1.	

### 3.2 Air Flow Measurements

Room reference (location of terminals)	Measured Air Flow High Rate (l/s)	Design Air Flow High Rate (l/s) Refer to Table 5.1a ADF	Measured Air Flow Low Rate (l/s)	Design Air Flow Low Rate (l/s) Refer to Table 5.1a in ADF
Kitchen				
Bathroom				
En Suite				
Utility				
Other...				

**3.3 Commissioning**

Tick as appropriate

Have controls been set-up in accordance with the manufacturer's recommendations?

**Yes****No****3.4 Test Engineer's Details**

Name

Company

Address Line 1

Address Line 2

Telephone Number

Post Code

Signature

Competent Person Scheme /  
Registration Number (if applicable)

Date of Test

All information is believed correct at time of going to press. All dimensions referred to are in millimetres unless otherwise shown. E&OE.

All goods are sold according to Zehnder Group UK Ltd's Standard Conditions of Sale which are available on request. See website for warranty period details.

Zehnder Group UK Ltd reserves the right to change specifications and prices without prior notice. © Copyright Zehnder Group UK Ltd 2017.

## **Zehnder Group UK Limited**

Watchmoor Point, Camberley,  
Surrey, GU15 3AD

Customer Services: +44 (0) 1276 408404  
Technical Services: +44 (0) 1276 408402  
Email: [info@greenwood.co.uk](mailto:info@greenwood.co.uk)  
Web: [www.greenwood.co.uk](http://www.greenwood.co.uk)

