

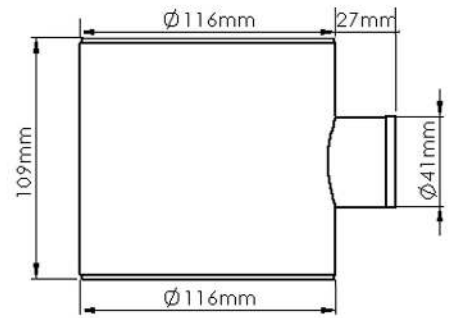

PRODUCT DATA SHEET

DUCVKC434

CONDENSATION TRAP WITH OVERFLOW

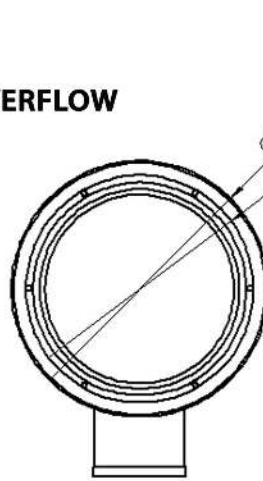

SPECIFICATION DETAILS

The DUCVKC434 100mm diameter Condensation Trap is manufactured from (white) PVC and has a minimum free area of 5,594mm². It has a female adaptor for connection to the outside of our System 100 Round Ducting.

The Condensation Trap is installed at the lowest point in vertical rises where moisture from condensation can occur. The DUCVKC434 captures any moisture running down the inside of the duct and is drained via a 22mm overflow pipe connector.

DUCVKC434 is manufactured in compliance with Domestic Plastic Ductwork Specification DW/154 and does meet UL94HB flammability standard.

DUCVKC434 has been designed for use with Kair System 100 Round.

Manufacturer:	Kair Ventilation
Part Number:	DUCVKC434
Size:	100mm Diameter
For use with:	Kair System 100
Box quantity:	7
Individual Weight:	1900g
Colour:	White

MAX/MIN OPERATING TEMPERATURES

+ 60°C to - 15°C

PERFORMANCE CURVE

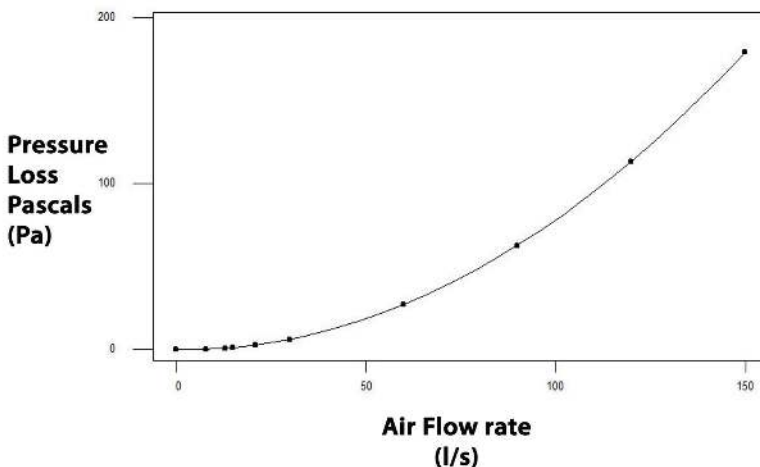

AIRFLOW	RESISTANCE
8 l/s	0.18 pa
13 l/s	0.80 pa
21 l/s	2.65 pa
30 l/s	5.90 pa
60 l/s	26.90 pa
120 l/s	113.52 pa

Associated Ancillaries

