

The MRXBOX family is growing... but the size isn't



# NEW MRXBOX ECO5



Compact case size

Low SFP

You told us what you needed out of an MVHR unit and we delivered.

MRXBOX is Nuaire's award-winning range of MVHR systems. Units are designed to provide optimised and balanced extract and supply ventilation with superior levels of heat recovery.

But our customers told us that our MRXBOX range of MVHR units was missing something - a medium-sized unit with high performance.

## Introducing MRXBOX-ECO5

Our new MRXBOX-ECO5 unit comes in the same sized case as our ECO3 units, with higher airflow at selected duty points. This makes specifying easier on projects with space restrictions.

### SAP 2012 Results

K+n wet rooms	SFP (W/l/s) [2012]	Efficiency (%) [2012]
n = 1	0.63	90%
n = 2	0.61	89%
n = 3	0.68	88%
n = 4	0.79	87%
n = 5	0.91	86%

### Performance

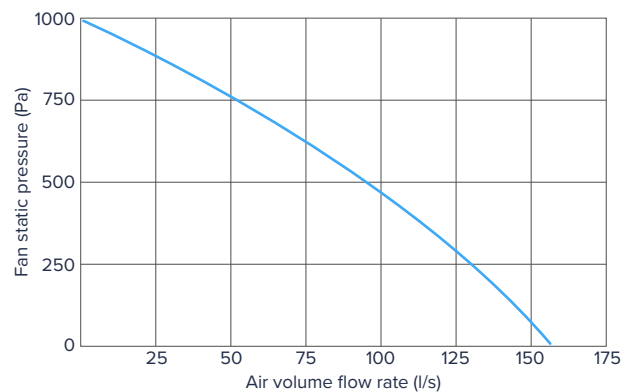

### Dimensions

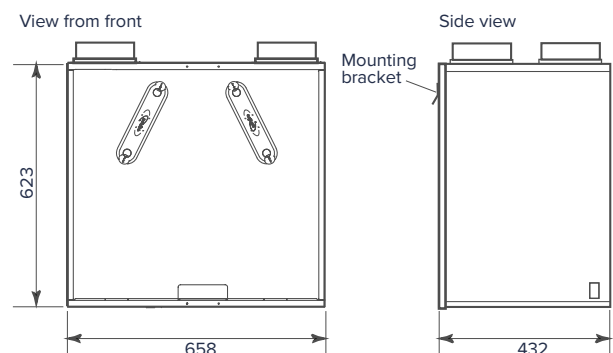

For more information visit [www.nuaire.co.uk/ECO5](http://www.nuaire.co.uk/ECO5) or call 029 2085 8500.

