



KWH150-ECO-HEAT-HCS

Whole House Ventilation Unit With Hall Control

Installation Manual



1.0 SAFETY INFORMATION

- The provision of the electrical supply and the connection of the unit to the mains must be carried out by a qualified electrician.
- Isolate from power supply before removing any covers. During installation / maintenance ensure all covers are fitted before switching on the mains supply.
- All-pole disconnection from the mains as shown in the wiring diagram must be incorporated within the fixed wiring and shall have a minimum contact separation of 3mm in accordance with latest edition of the wiring regulations.
- This unit must be earthed.
- Ducting must be securely fixed with screws to the spigot(s) to prevent access to live parts. Duct runs terminating close to the fan must be adequately protected by suitable guards.
- If the supply cord is damaged, it must be replaced by the manufacturer, its service agent or similarly qualified persons in order to avoid a hazard.
- Precautions must be taken to avoid the back-flow of gases into the room from the open flue of gas or other fuel-burning appliances.
- This appliance should not be used by children or persons with reduced physical, sensory or mental capabilities or lack of experience and knowledge, unless they have been given supervision or instruction concerning the safe use of the appliance by a person responsible for their safety. Children shall not play with the appliance. Cleaning and user maintenance shall not be carried out by children.
- In order to avoid a hazard due to inadvertent resetting of the thermal cut-out, this appliance must not be supplied through an external switching device, such as a timer, or connected to a circuit that is regularly switched on and off by the utility.
- The heater unit must be connected to the ceiling vent and fan unit using the 3 looms that protrude from the heater module.

1.1 Hazard Symbols



ELECTRIC SHOCK

This unit must be completely electrically isolated before any panels are removed. Check mains supply and control connections.



REFER TO INSTRUCTION MANUAL

Read and understand the installation and maintenance manual before installing, operating or maintaining this product.

1.2 Important Information

This manual contains important information on the safe and appropriate assembly, transport, commissioning, operation, maintenance, disassembly and simple troubleshooting of the product.

While the product has been manufactured according to the accepted rules of current technology, there is still a danger of personal injury or damage to equipment if the following general safety instructions and the warnings contained in these instructions are not complied with.

- Read these instructions completely and thoroughly before working with the product.
- Keep these instructions in a location where they are accessible to all users at all times.
- Always include the operating instructions when you pass the product on to third parties.

1.3 Personal Protective Equipment

The following minimum Personal Protective Equipment (PPE) is recommended when interacting with Kair product:

- Protective Steel Toed Shoes - when handling heavy objects.
- Full Finger Gloves (Marigold PU800 or equivalent) - when handling sheet metal components.
- Semi Fingerless Gloves (Marigold PU3000 3DO or equivalent) - when conducting light work on the unit requiring tactile dexterity.
- Safety Glasses - when conducting any cleaning/cutting operation or exchanging filters.
- Reusable Half Mask Respirators - when replacing filters which have been in contact with normal room or environmental air.

Kair would always recommend a site specific risk assessment by a competent person to determine if any additional PPE is required.

2.0 INTRODUCTION

The KWH150-ECO-HEAT-HCS provides whole home ventilation using the Positive Input Ventilation principle. The concept is to introduce fresh, filtered air into the dwelling at a continuous rate, encouraging movement of air from inside to outside. To achieve this the unit is mounted in the loft space, drawing air through the filters and inputting it, at ceiling level, into the property.

The KWH150-ECO-HEAT-HCS fan unit includes an internal sensor to regulate the fan speed according to the temperature of the loft. The internal sensor is to increase airflow to the dwelling when the loft is warmer than the house. The units 'Fixed Temperature Heat Recovery' strategy shall be achieved via a sensor located in the unit and shall improve energy performance accordingly. This unit has all the controls for the fan in the ceiling vent allowing the user to control, programme and monitor the unit from inside the property. A heater section incorporating a 400W heating element shall be fitted to the fan unit. It shall be electronically controlled so as to minimise energy use. A temperature sensor shall be fitted to the outlet of the heater and will control the output of the heater in an attempt to maintain the set point. The set point will be adjustable between 5°C and 15°C.

Once installed, the airflow can be set to suit the house size and, if required, the way it responds to the temperature changes within.

3.0 GENERAL INSTALLATION

Successful operation of the fan depends entirely upon the unit being installed strictly in accordance with these instructions.

Please read through this guide in its entirety before commencing installation and follow step by step to ensure a satisfactory completion.

Whilst the installation of the unit may be achieved by suitable persons, the provision of the electrical supply and the connection of the unit to the mains must be carried out by a qualified electrician.

Warning: Isolate from power supply before removing any covers. During installation/maintenance ensure all covers are fitted before switching on the mains supply.

This appliance can be used by children aged from 8 years and above and persons with reduced physical, sensory or mental capabilities or lack of experience and knowledge if they have been given supervision or instruction concerning use of the appliance in a safe way and understand the hazards involved. Children shall not play with the appliance. Cleaning and user maintenance shall not be made by children without supervision.

Precautions must be taken to avoid the back-flow of gases into the room from the open flue of gas or other fuel-burning appliances.

Means for disconnection must be incorporated in the fixed wiring as shown in the wiring diagram in accordance with IEE wiring or national wiring rules.

CAUTION: In order to avoid a hazard due to inadvertent resetting of the thermal cut-out, this appliance must not be supplied through an external switching device, such as a timer, or connected to a circuit that is regularly switched on and off by the utility.

3.1 Loft Inspection

Check to ensure that the loft has adequate ventilation. There may be occasions where a loft is so well sealed that additional ventilation may have to be provided by the owner/occupier.

- Ensure that all water tanks are covered and sealed.
- Check that all water pipes are lagged.
- Ensure that any extract fans are discharging to outside and not into the loft.
- Check that the loft hatch is tightly sealed.
- Ensure that all holes in the ceilings are sealed i.e. ceiling light fittings etc.
- Check any flues or chimneys for leakage in the loft via a visual inspection, should be carried out by the installer.
- If any leakage points are found, or if there is any doubt at all, then the installer should advise the house owner/provider as soon as possible and seek instruction from them before proceeding with the installation.

4.0 DIFFUSER INSTALLATION

4.1 Siting The Diffuser

The diffuser has a unique air throw pattern and it is essential that it is located correctly in the central hallway in single storey properties or in the ceiling of the top floor landing on 2 or more storey dwellings.

The diffuser discharges air evenly in all directions along the underside of the ceiling.

Speed Setting	Minimum Distance Of Diffuser From Wall
1	100mm
2	155mm
3	400mm
4	625mm
5	850mm
6	1000mm

SMOKE ALARMS - It is also important to ensure that the diffuser is NOT placed within 1 metre of a smoke alarm.

If the diffuser cannot be repositioned, the diffuser must be positioned so as to encourage the air through the 2 open sides that face at least 1.5 metres of unobstructed area away from the smoke alarm sensor.

4.2 Fitting The Air Dams (If Required)

Air dams are provided to alter the direction of airflow and should be fitted as needed. 2 air dams are supplied and will fit on any of the diffuser sides to guide airflow away from a smoke detector and/or obstructions.

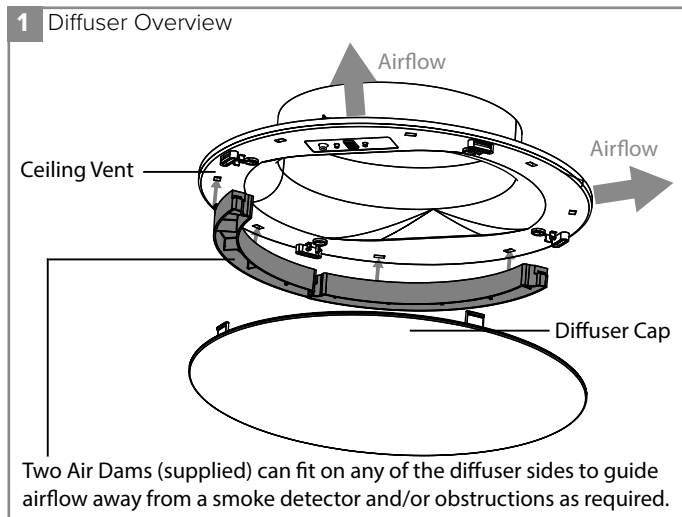

4.3 Fitting The Ceiling Diffuser

To install the diffuser, use the tear-out template from the lid of the unit packaging and trace the shape onto the ceiling between two convenient joists. The shape is elliptical to allow space for the PCB of the controls and this should be positioned for ease of access (i.e. NOT facing over a stairwell). Once the shape has been cut out, position the ceiling and secure it in place using the 4 screws and plugs provided. After fitting attach the diffuser cap to the frame using the four built-in press on clips provided.

5.0 HEATER INSTALLATION

The heater unit must be electrically connected to the ceiling vent and fan unit using the 3 looms that protrude from the heater module. Connect the ceiling vent control loom to the circuit board on the ceiling vent and insert the heater module into the ceiling vent. Connect the interconnect loom into the rear of the fan unit. Connect the mains power loom into the power outlet on the underside of the fan unit.

The flexible duct (maximum length 2m) is connected to the base unit by inserting the duct over the outlet duct and held in place using the supplied cable tie.

Push heater enclosure onto the back of the ceiling diffuser ensuring all four clips engage.

Finally when installing the duct to the heater unit insert the duct over the back of the heater, over the four protruding lugs and fasten the cable tie below. This ensures that the duct will be held on securely, check all duct joints are air tight.

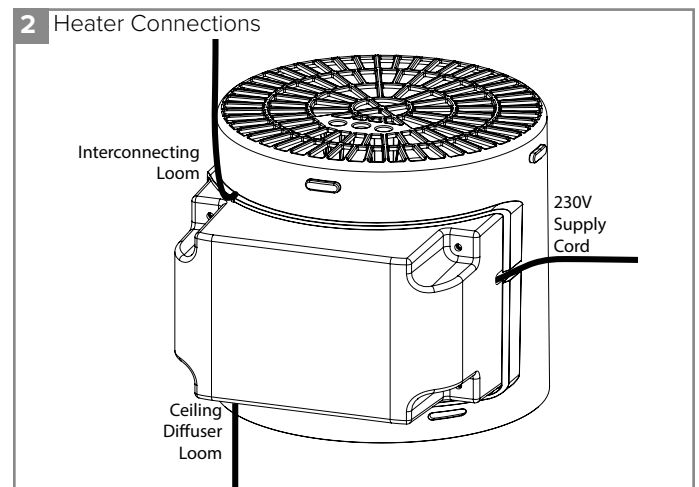

6.0 FILTER INSTALLATION

The filter has a push fit rim to attach itself to the main body of the unit. Offer the filters up to the unit and apply a small amount of pressure to the filters rim (by hand). The filter will clip into place.

The unit can then be attached to the roof via the cord provided (or fixed to the floor joists using the optional anti vibration mounting kit).

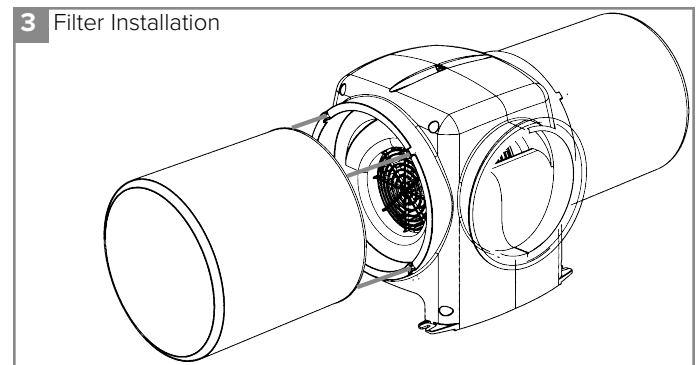

7.0 KWH150-ECO-HEAT-HCS INSTALLATION

7.1 Joist Hung (Standard Mounting)

The standard method of installation is to suspend from a convenient roof beam via the cord supplied (Note: unit weight = 3.5 kg). The method of locating the cord to the roof timber is the responsibility of the installer.

The flexible duct (maximum length 2m) is connected to the fan unit by inserting the duct over the fan outlet and held in place using the supplied cable tie. This method is repeated when connecting the duct to the ceiling vent. Note: Ensure all duct joints are airtight.

The flexible ducting should NOT be installed in a compressive state, as this will negatively impact on the performance of the unit.

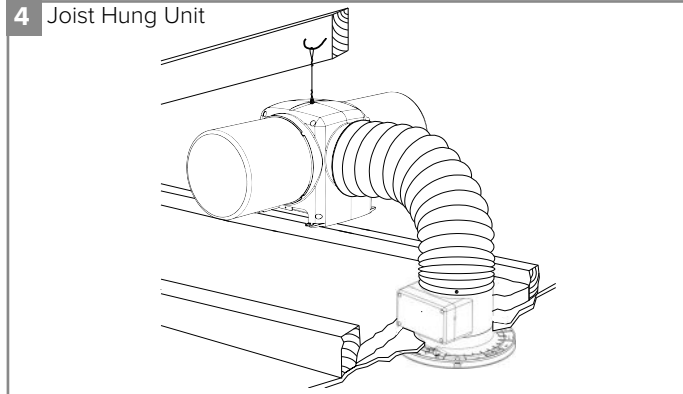

7.2 Anti-Vibration Mounts (Optional)

The AV kit contains all the parts necessary to complete a joist mounted installation. If AV mounts are required, the kit can be purchased direct from Kair using the following part number: **771393**.

Lower the unit with battens (not supplied) attached to the joists. Mark and drill the 12mm diameter clearance holes required in the ends of the battens. Place anti-vibration mounts above and below each batten fixing point and, using the 4 large screws and special washers, fix the unit to the joists.

Do not overtighten the fixings. The distance from the top washer to the joist when installed must not be less than 50mm.

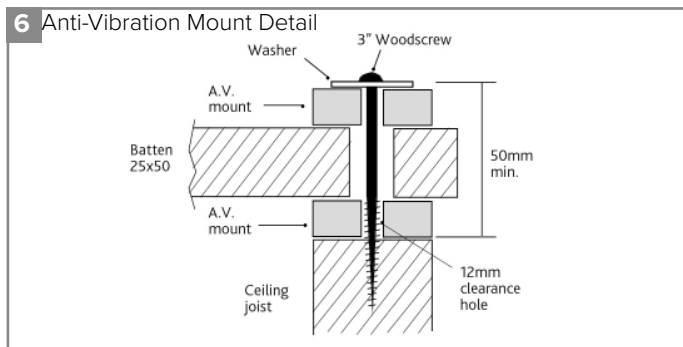
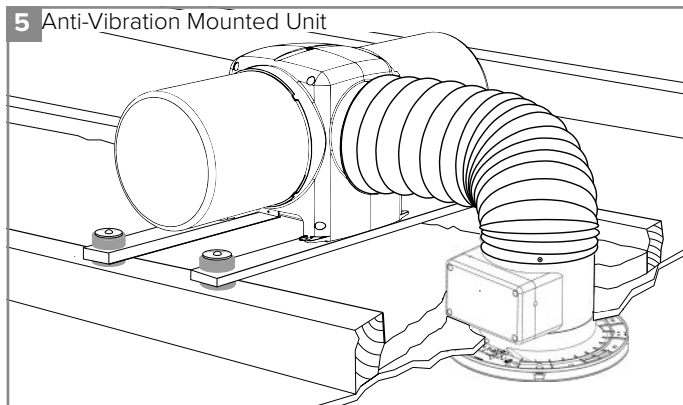

8.0 ELECTRICAL INSTALLATION

8.1 Electrical Information

The electrical connection of the unit must be carried out by a qualified electrician.

- Voltage:** 230V 1ph 50Hz
- Consumption:** 1.6W(min) 15.3W(max) Up to 422W with heater at full load.
- Fuse size:** 3 Amp

The fan unit is also supplied with a fused spur. The three core mains cable from the power supply should be connected to a fixed wiring installation, via the spur, in accordance with current IEE wiring regulations.

Disconnection from mains must be incorporated within the fixed wiring and shall have a maximum contact separation of 3mm in accordance with latest edition of the wiring regulations.

For good EMC engineering practice, the KWH150-ECO-HEAT-HCS power supply output cable and any sensor cables should not be placed within 50mm of other cables or each other.

8.2 Wiring Diagram

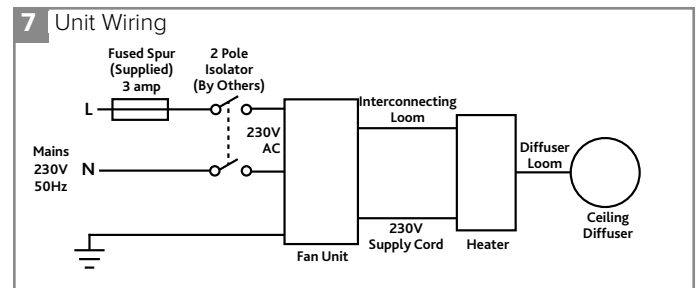

8.3 Replacing a Supply Cord

If the mains supply cord to the PSU is damaged, it must be replaced by the manufacturer, its service agent or similarly qualified persons in order to avoid a hazard.

9.0 SMOKE / CARBON MONOXIDE ALARM AUTOMATIC SHUT DOWN

If the unit is required to switch off in the event of smoke/CO detection, alarms are available with separate relay bases from companies such as:

- Kidde – www.kiddesafetyeurope.co.uk**
- Aico Ltd – www.aico.co.uk**

This is a mandatory requirement for all units installed in a 3 Storey property.

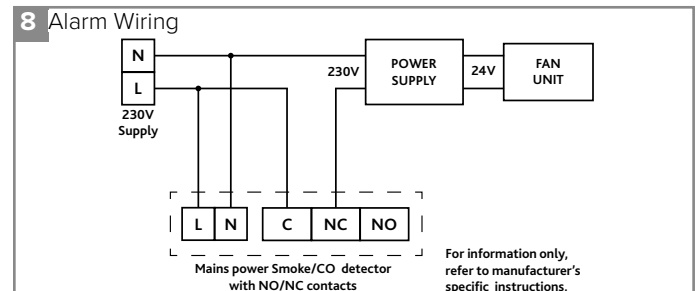

10.0 CONTROLS

In the event of conducted RF interference between 80 to 127 MHz or transient radiated interference between 80 to 87 MHz, the unit may go into standby mode or the LED display may go blank and fan stop temporarily, then go into reset mode (LED flashing with the number of the speed setting) and run at high speed.

The unit will return to normal after 2 minutes after the RF interference has stopped.

10.1 Speed Settings

The unit has 5 air flow rate (speed) settings, 2-6. Switches to control the speed settings and the display are located on the underside of the diffuser. The following table shows the flow rates and their corresponding speed settings.

As an example a one bedroom bungalow should be set to speed 2, and a large 5 bedroom detached property would require speed 6.

Speed Setting	Airflow Rate (litres / Second)
0	Standby (0)
1	10*
2	20
3	30
4	40
5	50
6	60

*At speed 1 the heater will not be enabled.

10.2 Selecting a Speed

When power to the unit is switched on the display will show the temperature control option for 2 minutes. Once the start-up pattern has completed you may now press the “up” or “down” switch to choose the flow rate appropriate to the property you are installing the unit in.

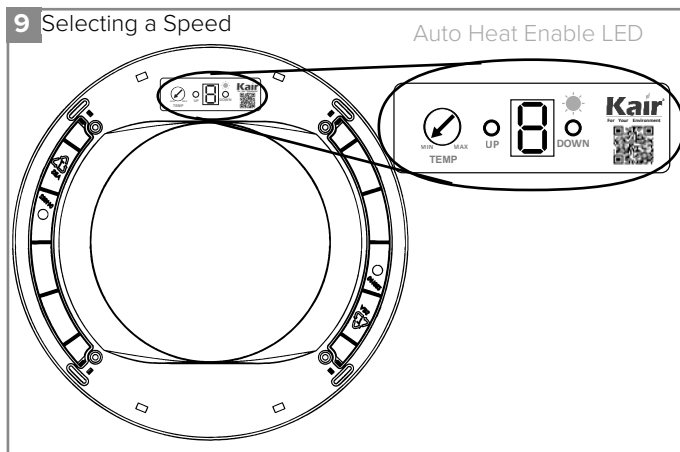

10.3 Setting the Temperature Control Option

When delivered, the unit is set to temperature setting 1 as a default. To change this setting, switch the power to the unit on via the isolator (supplied by others). The display in the ceiling vent will show the start-up pattern for two minutes and the unit will be running at speed 6. In this time you can change the temperature setting by pressing and holding the “up” switch. The display will show a flashing value of 1 and will increase every 4 seconds.

Once you have reached the temperature setting you require press and release the “down” button to store the setting. The fan will now enter into its normal speed setting mode and a speed can be selected at this point.

Option	Temperature Control Description
1 (Default)	At loft temperatures below 19°C the unit will operate on “ Normal Operation Mode ”. At loft temperatures above 18°C but less than 24°C, the unit will switch automatically to “ Intelligent Heat Recovery Mode ”. At loft temperatures above 23°C the unit will switch itself automatically to “ Standby Mode ”.
2	At loft temperatures below 19°C the unit will operate on “ Normal Operation Mode ”. At loft temperatures above 18°C but less than 31°C, the unit will switch automatically to “ Intelligent Heat Recovery Mode ”. At loft temperatures above 30°C the unit will switch itself automatically to “ Standby Mode ”.
3	This option removes the temperature sensing function out of the unit. The unit will operate continuously in “ Normal Operation Mode ” depending on the volume control setting selected.
4	At loft temperatures below 16°C the unit will operate on “ Normal Operation Mode ”. At loft temperatures above 15°C but less than 28°C, the unit will switch automatically to “ Heat Recovery Mode ”. At loft temperatures above 27°C the unit will switch itself automatically to “ Standby Mode ”.
5	Not applicable for the HEAT model.

10.4 Setting the Temperature Set Point

10.5 A temperature sensor is fitted to the outlet of the heater and will control the heater output to maintain the set point. The set point ranges between 5°C (fully anti-clockwise) and 15°C (fully clockwise) and can be adjusted via the min/max commissioning pot located on the ceiling vent diffuser.

10.6 Heater On (Auto Heat) / Off Control

When the orange LED on the diffuser control panel is illuminated, the heater is active in autoheat mode and is controlled by the temperature setpoint. When the orange LED is not lit, the heater is off.

In order to enable the heater, press the DOWN button for three seconds and release. The orange LED will illuminate indicating that the heater is active and in auto heat mode.

To turn the heater off, press the DOWN button for three seconds and release. The Orange LED will no longer be illuminated, indicating that the heater is off. **Heater is enabled only when the orange LED is illuminated.**

11.0 MAINTENANCE

Isolate before commencing work, make sure that the unit, switched live and Kair control are electrically isolated from the mains supply and switched live supply.

It is important that maintenance checks are recorded and that the schedule is always adhered to, in all cases, the previous report should be referred to.

11.1 Filter Maintenance

The filters are required to be changed every five years, failure to do so may impair the performance and energy efficiency of this unit. The unit display will show the letter 'C' once 5 years of use has elapsed.

New filters can be purchased direct from Kair using the following part number: **KWH150-ECO-FLT** (five year filter). To reset the change filter message, press and hold BOTH "up and "down" button until the letter 'C' starts to flash then release and press the "down" button.

If the units' performance has been reduced dramatically or black dust becomes visible around the outlet diffuser, check that the filter has not become dislodged in any way.

12.0 WARRANTY

The Kair 7 year warranty against faulty material or workmanship starts from the day of delivery and is limited to replacement parts only.

This warranty is void if the equipment is modified without authorisation, is incorrectly applied, misused, disassembled, or not installed, commissioned and maintained in accordance with the details contained in this manual and general good practice.

The product warranty applies to the UK mainland only and in accordance with our Conditions of Sale.

END-OF-LIFE AND RECYCLING

Where possible Kair use components which can be largely recycled when the product reaches its end-of-life:

- Fans, motors, controls, actuators, cabling and other electrical components can be segregated into WEEE recycling streams.
- Sheet metal parts, aluminium extrusion, heating/cooling coils and other metallic items can be segregated and fully recycled.
- EPP, plastic ducting, nylon corner pieces, plastic heat exchangers, packaging material and other plastic components can be segregated into mixed plastic and widely recycled.
- Cardboard packaging, wood, used filters and other paper components can be largely recycled or fully processed in energy from waste centres.
- Remaining Items can be further segregated and processed in accordance with the zero waste hierarchy. Please call After Sales Support for further information on items not listed above.

Ensure that Kair product is made safe from any electrical / water / refrigerant supplies before dismantling commences. This work should only be undertaken by a qualified person in accordance with local authority regulations and guidelines, taking into account all site based risks.

13.0 FREQUENTLY ASKED QUESTIONS

While very rare, issues with newly installed units can occur. Typically these issues can be easily solved by referring to the below table.

Symptom	Cause	Solution
Fan not running.	NO power to the unit (Display is NOT lit).	Ensure unit has not been switched off or that the local fuse has not blown.
	Software error - Power to the unit (Display is lit).	If electricity present, power off, wait and power on again – this may restart the unit.
	Fan failure - Power to the unit ('F' is flashing on display).	Fan has failed and a replacement unit is required.
	High loft temperature.	This is normal, see temperature control options.

14.0 AFTER SALES AND REPLACEMENT PARTS

For technical assistance or further product information, including spare parts and replacement components, please contact the After Sales Department.

If ordering spares please quote the serial number of the unit together with the part number, if the part number is not known please give a full description of the part required. The serial number will be found on the identification plate attached to the unit casing.

A QR code linking directly to the Kair website is located behind the diffuser plate and can be used to order spare parts and replacement components.

Telephone 020 8463 9695
aftersales@kair.co.uk

Technical or commercial considerations may, from time to time, make it necessary to alter the design, performance and dimensions of equipment and the right is reserved to make such changes without prior notice.

