

DOMUS 297 Condensate Drainage Kit (refer to HRX or HRX2 installation and operating instructions)

- 1 Using a small amount of solvent weld suitable for ABS pipe fittings (not supplied), attach the threaded socket to the selected condensate outlet spigot. **Important:** follow the health and safety and user instructions supplied with the solvent weld. This is particularly important when working in confined spaces.

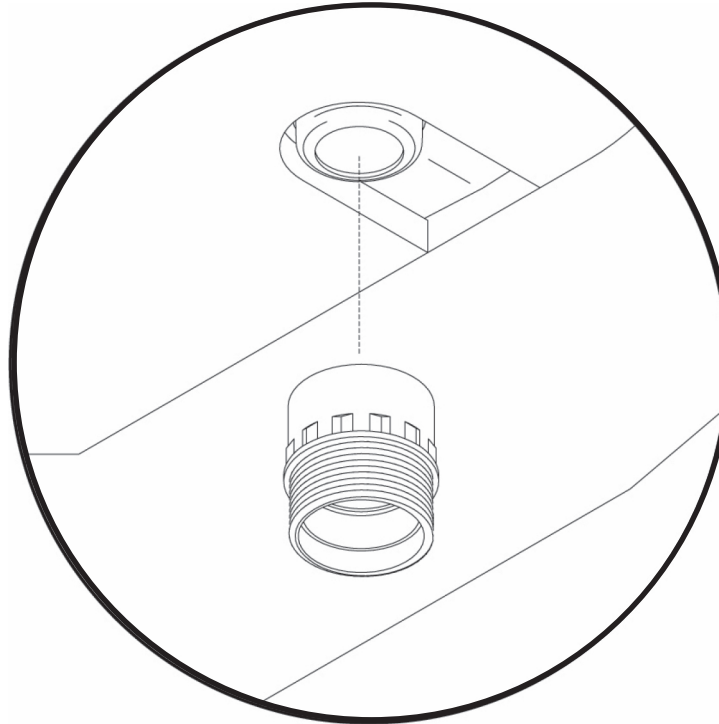

- 2 When the threaded socket is secure, fit and hand-tighten the threaded elbow making sure that the rubber seal washer is seated correctly.
- 3 To ensure that the waterless trap operates correctly, run a trickle of water from a tap through the trap in the direction of the arrows. Gently push the waterless trap onto the elbow stem. **Important:** Check that the arrows printed on the trap point away from the HRX unit (in the direction of flow).
- 3 Using the remainder of the kit items complete the condensate drain-system to suit the dwelling layout. **Important:** The drain must incorporate a continuous fall of no less than 5° (87.5mm in every 1000mm) to the nearest waste water network.
- 4 The condensate drain system should be adequately supported and suitably insulated if it passes through unheated spaces and voids (e.g. loft spaces) to prevent freezing.

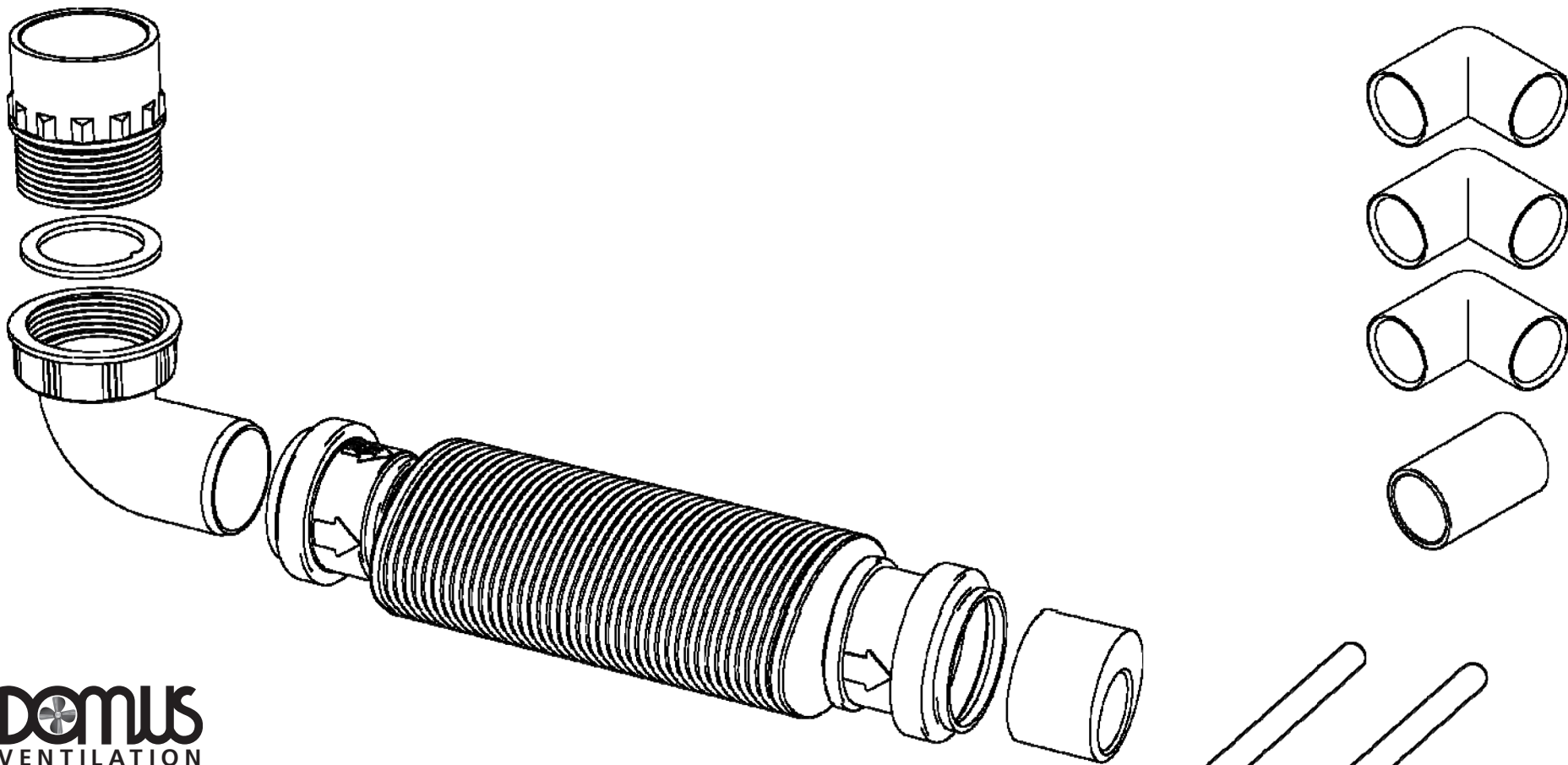

Domus
VENTILATION

Domus Ventilation
Cambria House
Caerphilly Business Park
Van Road
Caerphilly
CF83 3ED
Tel: +44 (0)3443 715523
Fax: +44 (0)3443 715524
Email: vent.info@domusventilation.co.uk
www.domusventilation.co.uk

2 x 980mm Ø21.5mm ABS PIPE

Domus
VENTILATION