

Lo-Carbon SOLO Plus SELV Centrifugal Bathroom/Toilet Fan

Installation and Wiring Instructions

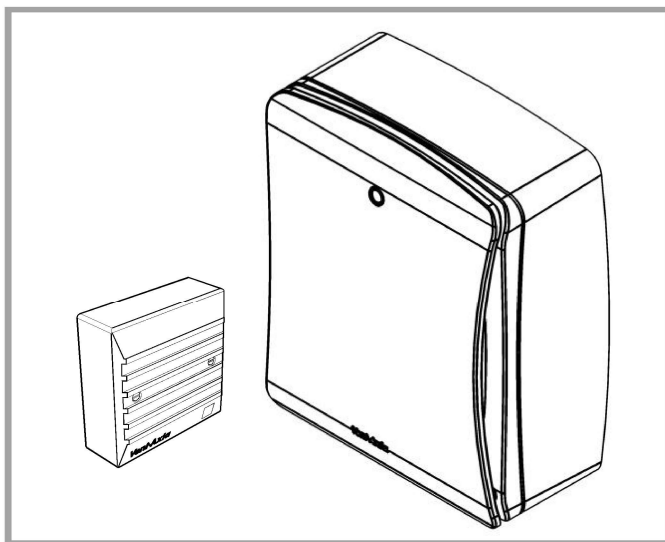

Stock Ref. N°

427485B (P)
427486B (T)
427487B (HT)
427488B (TM)

FAN UNITS 12V DC SELV (CLASS III)
CONTROLLERS 220-240V 50Hz MAINS SUPPLY (CLASS II)
WITH 12V DC SELV OUTPUT

Vent-Axia®

PLEASE READ INSTRUCTIONS IN CONJUNCTION WITH THE ILLUSTRATIONS.
PLEASE SAVE THESE INSTRUCTIONS

T

IPX7
(FAN)

AVAILABLE NOW FROM

i-sells.co.uk



Showroom:
2 St John's Parade
Sidcup High Street
DA14 6ES

EMAIL: sales@i-sells.co.uk
SALES: 020 8463 9696
FAX: 08456 44 60 02
WEB: <http://www.i-sells.co.uk>

CE

Installation and Wiring Instructions for the Lo-Carbon SOLO Plus SELV Bathroom Extract Fan.



**IMPORTANT:
READ THESE INSTRUCTIONS BEFORE COMMENCING THE INSTALLATION**

DO NOT install this product in areas where the following may be present or occur:

- Excessive oil or a grease laden atmosphere.
- Corrosive or flammable gases, liquids or vapours.
- Ambient temperatures higher than 40°C or less than -5°C.
- Possible obstructions which would hinder the access or removal of the Fan.

SAFETY AND GUIDANCE NOTES

- A.** All wiring to be in accordance with the current I.E.E. Regulations, or the appropriate standards of your country and **MUST** be installed by a suitably qualified person.
- B.** The Fan should be provided with a local isolator switch capable of disconnecting all poles, having a contact separation of at least 3mm.
- C.** Ensure that the mains supply (Voltage, Frequency, and Phase) complies with the rating label.
- D.** The Fan should only be used in conjunction with the appropriate Vent-Axia products.
- E.** It is recommended that the connection to the fan connector terminals is made with flexible cable.
- F.** When the Fan is used to remove air from a room containing a fuel-burning appliance, ensure that the air replacement is adequate for both the fan and the fuel-burning appliance.
- G.** The Fan should not be used where it is liable to be subject to direct water spray for prolonged periods of time.
- H.** Where ducted Fans are used to handle moisture-laden air, a condensation trap should be fitted. Horizontal ducts should be arranged to slope slightly downwards away from the Fan.
- I.** This appliance is not intended for use by persons (Including children) with reduced physical, sensory or

mental capabilities, or lack of experience and knowledge, unless they have been given supervision or instruction concerning use of the appliance by a person responsible for their safety.

J. Young children should be supervised to ensure that they do not play with the appliance.

K. Fans used for tropical climates.

IMPORTANT:- ONLY CONNECT TOGETHER PRODUCTS FROM THE LO-CARBON SOLO PLUS SELV RANGE SINCE THE FANS ARE SPECIALLY DESIGNED TO WORK ON 12V DC AND ARE NOT COMPATIBLE WITH OTHER VENT-AXIA CONTROLLERS. DO NOT CONNECT MORE THAN ONE FAN TO THE CONTROLLER.

DESCRIPTION

As standard, the Lo-carbon SOLO Plus SELV is suitable for panel/wall installations, flush or surface mounting, either in a horizontal or vertical plane. 100mm ducting (flexible or straight) can be attached using the supplied adjustable spigot, providing rear or side exit options. Adaptors for System 25 and System 50 ducting can be used in conjunction with the adjustable spigot. For wall installations a Wall Kit (25 41 02 White / 25 41 00 Brown) can be used. An optional filter is also available (449265). Please see our catalogue or web site (www.vent-axia.com) for more information on System 25/50 and for alternative ducting and termination options.

SITING THE CONTROLLER

1. The controller must not be installed in a shower cubicle or enclosure. It must be sited away from direct sources of water spray and out of reach (1.5m) of a person using a fixed bath or shower.
2. Site away from direct sources of heat. Ambient temperature range 0 to 40°C. Do not site in an area containing excessive levels of grease.
3. Decide where to site the controller and fan (see section siting the fan), and work out the required cable runs.

SITING THE FAN

1. The electrical supply to this fan is 12V DC SELV from the mains controller. This means that the fan may be installed within reach of a person using a fixed bath or shower, i.e. in a nearby wall. However, the fan must not be placed where it could be submerged in water or regularly exposed to direct water spray, e.g. from a shower head whether permanently fixed or movable.

A. INSTALLATION

PANEL MOUNTING (Surface)

1. Cut a 105mmØ hole through the panel, ensuring that there is sufficient space for the product to be installed and that the filter (If fitted) can be removed for maintenance.
2. Removing the grille. Firstly remove the front cover by carefully pulling each corner of the front panel until it is free to be removed from the inner grille (Fig 1). Unscrew the two screws at the bottom of the inner grille. The screws will remain in the inner grille but will be loose when the grille is ready to be removed (Fig 1). Lift the inner grille from the bottom edge ensuring not to damage the sensor cable (TM model only) attached to the front assembly and Base Housing (Fig 6).
3. Remove the Spigot Ring from inside the carton and clip over the Spigot Adaptor making sure the lip on the Spigot Ring locates firmly inside the groove on the Spigot Adaptor (Fig 2). Ensure that the Spigot Adaptor is firmly located onto the Base Housing and the shutter is still securely fastened and fully functional.
4. Set-up the appropriate speed selection and other features as outlined in **Section B SETUP.**
5. Attach the ducting to the Spigot and locate into the hole in the panel ensuring the Skirt is located correctly into the Base Housing. Secure into position using appropriate fixtures (Fig 3)
6. Ensure the Impeller rotates freely.
7. Select and follow the appropriate wiring diagram in **Section C WIRING.**
8. Replace the inner grille ensuring that the PIR sensor cable (TM model only) is reconnected to the PIR sensor PCB (Fig 6) Replace the front panel.
9. Switch the mains power supply on and check the fan is operating correctly.

PANEL MOUNTING (Flush)

1. Mark and cut a rectangular hole (190mm x 240mm) through the panel, ensuring that there is sufficient space for the product to be installed and that the filter (If fitted) can be removed for maintenance. **IMPORTANT:** Be careful to avoid joists and hidden cables.

2. Removing the grille. Firstly remove the front cover by carefully pulling each corner of the front panel until it is free to be removed from the inner grille (Fig 1). Unscrew the two screws at the bottom of the inner grille. The screws will remain in the inner grille but will be loose when the grille is ready to be removed (Fig 1). Lift the inner grille from the bottom edge ensuring not to damage the sensor cable (TM model only) attached to the front assembly and Base Housing (Fig 6).
3. Remove the Spigot Ring from inside the carton and clip over the Spigot Adaptor, making sure the lip on the Spigot Ring locates firmly inside the groove on the Spigot Adaptor (Fig 2). The Spigot can be repositioned for side exit installations by removing the screw and sliding the spigot away from the rear of the Base Housing, carefully observing the guide rails (Fig 4). The Spigot can then be rotated and repositioned for side exit using the same guide rails and retaining screw (Fig 4). Ensure that the Spigot Adaptor is firmly located onto the Base Housing in the required orientation and the shutter is still securely fastened and fully functional.
4. Remove the Skirt and pass the supplied screw fully through the flange of the base housing. Then attach the 3 supplied Panel Clips (Fig 5) and partially screw into place until they are properly retained (allowing enough gap for the panel thickness).
5. Set-up the appropriate speed selection and other features as outlined in **Section B SETUP.**
6. Attach the ducting to the Spigot and locate into the hole in the panel, ensuring the cable is fed into the Base Housing and the Panel Clips spring out behind the panel.
7. Secure into position by carefully tightening the Panel Clips. It maybe necessary to hold the product centrally in the hole while tightening so that no gaps are seen once the cover is on. **IMPORTANT: If power tools are used, set them to the minimum torque setting or preferably use a manual screwdriver. Do not over tighten.**
8. Ensure the Impeller rotates freely.
9. Select and follow the appropriate wiring diagram in **Section C WIRING.**
10. Replace the inner grille ensuring that the PIR sensor cable (TM model only) is reconnected to the PIR sensor PCB (Fig 6). Replace the front panel.
11. Switch the mains power supply on and check the fan is operating correctly.

WALL MOUNTING (Surface) For wall installations a Wall Kit (25 41 02 White / 25 41 00 Brown) can be used.

1. Cut a 115mm. Ø hole through the wall, ensuring that there is sufficient space for the product to be installed and that the filter (If fitted) can be removed for maintenance.
2. Insert the wall sleeve with the smaller diameter sleeve on the room-side and cement both ends into position flush with the wall faces. The wall sleeve should be angled downwards, away from the fan, to allow any condensation to drain to the outside wall.
3. Outside Grille: Using the Back Plate as a template, mark the fixing hole centres on the wall. Drill and plug the wall and fix the Back Plate into position.
4. Fix the Outside Grille on to the Back Plate (screws provided). Ensure the louvres are pointing downwards.
5. Removing the grille. Firstly remove the front cover by carefully pulling each corner of the front panel until it is free to be removed from the inner grille (Fig 1). Unscrew the two screws at the bottom of the inner grille. The screws will remain in the inner grille but will be loose when the grille is ready to be removed (Fig 1). Lift the inner grille from the bottom edge ensuring not to damage the sensor cable (TM model only) attached to the front assembly and Base Housing (Fig 6).
6. Remove the Spigot Ring from inside the carton and clip over the Spigot Adaptor making sure the lip on the Spigot Ring locates firmly inside the groove on the Spigot Adaptor (Fig 2). Ensure that the Spigot Adaptor is firmly located onto the Base Housing and the shutter is still securely fastened and fully functional.
7. Set-up the appropriate speed selection and other features as outlined in **Section B SETUP.**
8. Using the Base Housing as a template, mark the fixing hole centres on the wall, carefully sliding the spigot into the Wall Liner. Secure the Base Housing into position using the screws and fixings provided ensuring the Skirt is located correctly into the Base Housing (Fig 3).
9. Ensure the Impeller rotates freely.
10. Select and follow the appropriate wiring diagram in **Section C WIRING.**
12. Replace the inner grille ensuring that the PIR sensor cable (TM model only) is reconnected to the PIR sensor PCB (Fig 6). Replace the front panel.
13. Switch the mains power supply on and check the fan is operating correctly.

B. SETUP



WARNING: THE FAN AND ANCILLARY CONTROL EQUIPMENT MUST BE ISOLATED FROM THE POWER SUPPLY DURING THE INSTALLATION / OR MAINTENANCE.



IMPORTANT

On first power up, the fan will run through its initialization routine.
 On **T, HT & TM** models the fan will switch on and off during this routine (Including the LED)
 Once complete after approximately 2 minutes, the fan will run as normal.

1. SELECTING THE CONSTANT TRICKLE OPTION - Switch dip switch 2 into the ON position to activate the constant trickle operation. To disable the constant trickle option, move dip switch 2 into the OFF position. (Fig 7).

2. SELECTING THE TRICKLE SPEED (if enabled)

This will determine the speed at which the fan will run continuously if the constant trickle speed option is enabled (1 above).

- Low trickle speed – Switch dip switch 1 into the OFF position (Fig 7).
- High trickle speed – Switch dip switch 1 into the ON position (Fig 7).

3. SELECTING THE INSTALLATION RUNNING MODE

This will determine the speed at which the fan will run when activated by either the Pull-cord/LS line/Humidity/PIR.

- Wall mode – Switch dip switch 3 into the OFF position (Fig 7).
- Ducted mode – Switch dip switch 3 into the ON position (Fig 7).

4. SELECTING THE DELAY-ON OPTION (T and HT models) - Switch dip switch 4 into the ON position to activate the delay-on feature. This will prevent the fan from going to boost for approximately 2 minutes. If the Switch Live is disconnected (switched off) within this period the fan will not boost. If the Switch Live is still active after the period the fan will boost (Fig 7).

5. TIMER ADJUSTMENT (T, HT, TM models)

The overrun time period is factory set to 15 minutes. The overrun time period may be adjusted from 5-30 minutes by altering the adjuster on the control PCB [T] (Fig 7).

- i. To REDUCE the operating time, turn the adjuster [T] ANTI-CLOCKWISE (Fig 7).
- ii. To INCREASE the operating time, turn the adjuster [T] CLOCKWISE (Fig 7).

6. HUMIDITY ADJUSTMENT (HT model)

The fan's Humidity Set-Point is factory set to switch the fan on at 72%RH (Fig 7).

- i. To LOWER the Set-Point, turn the Humidity Adjuster [H] ANTI-CLOCKWISE. This makes the fan more sensitive to RH%, i.e. the fan will come on at a lower RH% (Fig 7).
- ii. To RAISE the Set-Point, turn the Humidity Adjuster [H] CLOCKWISE. This makes the fan less sensitive to RH%, i.e. the fan will come on at a higher RH% (Fig 7).

C. WIRING.



WARNING: THE FAN AND ANCILLARY CONTROL EQUIPMENT MUST BE ISOLATED FROM THE POWER SUPPLY DURING THE INSTALLATION / OR MAINTENANCE.

IMPORTANT

- **The Controller MUST** be surface mounted to allow air to freely circulate around the unit. When installed in a loft void it **MUST NOT** be enclosed or covered with insulation.
1. Select and follow the appropriate wiring diagram (Fig 8-9)
 2. It may be necessary to feed the mains cable around between the outside of the Base Housing and the Skirt to prevent the cable from being trapped.
 3. Check all connections have been made correctly and ensure all terminal connections and cable clamps are securely fastened.
 4. Ensure the impeller rotates and is free from obstructions.

D. SERVICING AND MAINTENANCE.



WARNING: THE FAN AND ANCILLARY CONTROL EQUIPMENT MUST BE ISOLATED FROM THE POWER SUPPLY DURING MAINTENANCE.

1. At intervals appropriate to the installation, the fan should be inspected and if required cleaned to ensure there is no build-up of dirt or other deposits.
 2. If a filter is fitted, remove the filter and wash in warm soapy water.
 3. Wipe the inlets and front face with a damp cloth until clean.
 4. Once the filter is dry it can be replaced.
- The fan has sealed for life bearings, which do not require lubrication.**

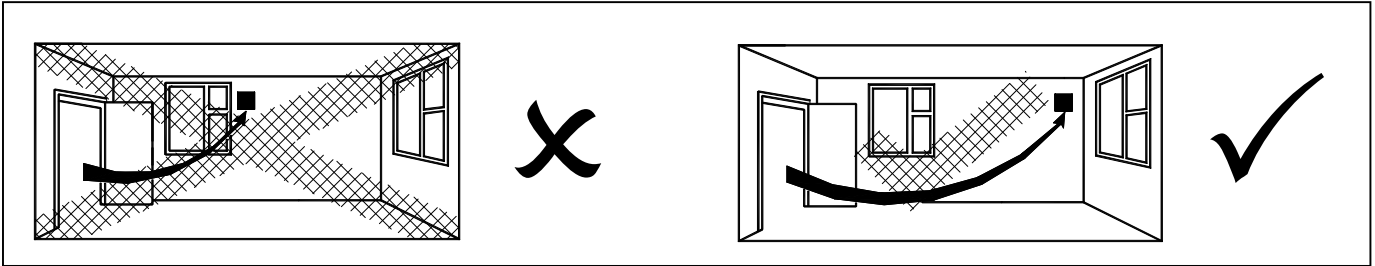

Fig. 1.
Removing the grille

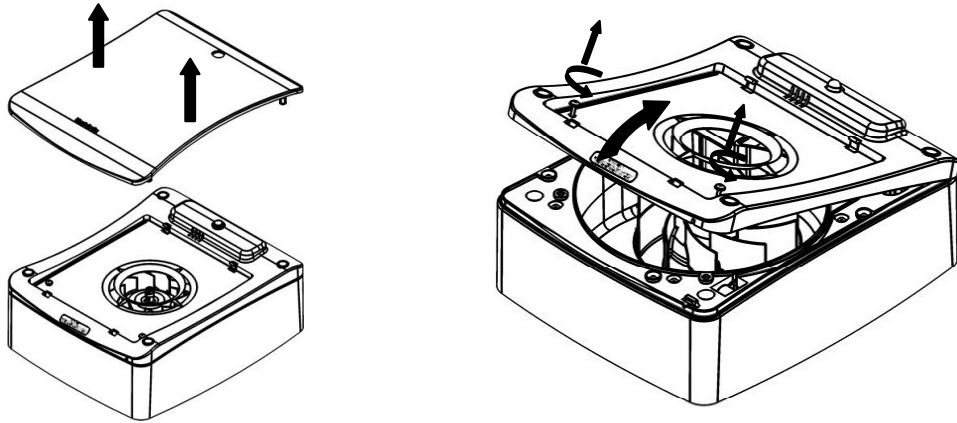

Fig. 2.
Attaching the spigot

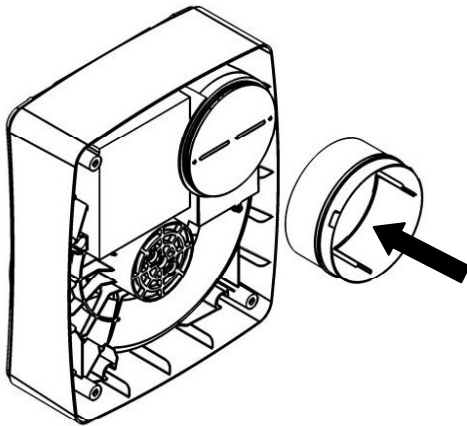

Fig. 3.
Surface mounting screw hole locations

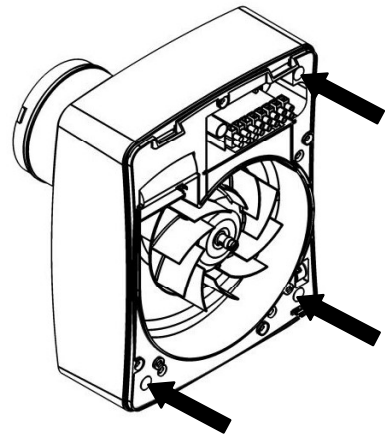

Fig. 4.
Converting outlet spigot for side exit and recess mounting

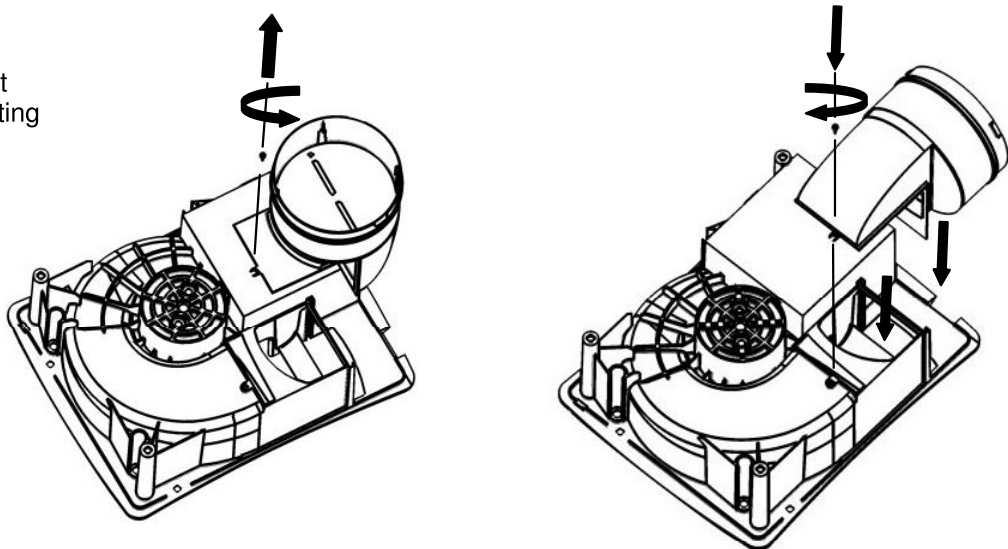

Fig. 5.
Recess mounting clips
In 3 positions.

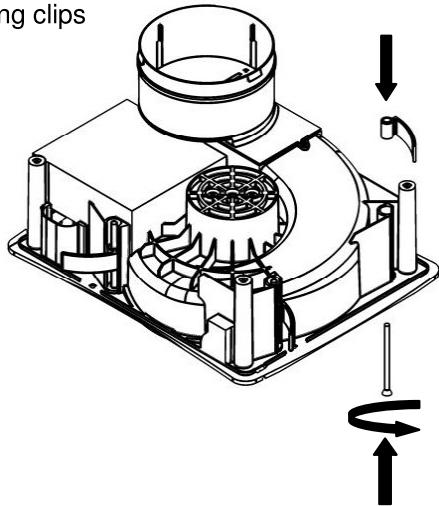

Fig. 6. PIR sensor cable - (**TM only**)



To remove the cover on TM models the sensor lead must be disconnected

Fig. 7. Settings

Top view of PCB cover showing pot locations
And dip switch location

LED position

Timer adjuster
(**T/HT/TM Models**)

To reduce time
Turn anti-clockwise.

To increase time
Turn Clockwise.

Humidity adjuster
(**HT Model**)

To LOWER the set-point
Turn Anti-clockwise.
To RAISE the set-point
Turn clockwise.

Dip switch
settings



- 1 = Trickle speed
- 2 = Constant trickle on or off
- 3 = Wall or Duct mode
- 4 = Delay-On timer on or off (Not on **TM** model)

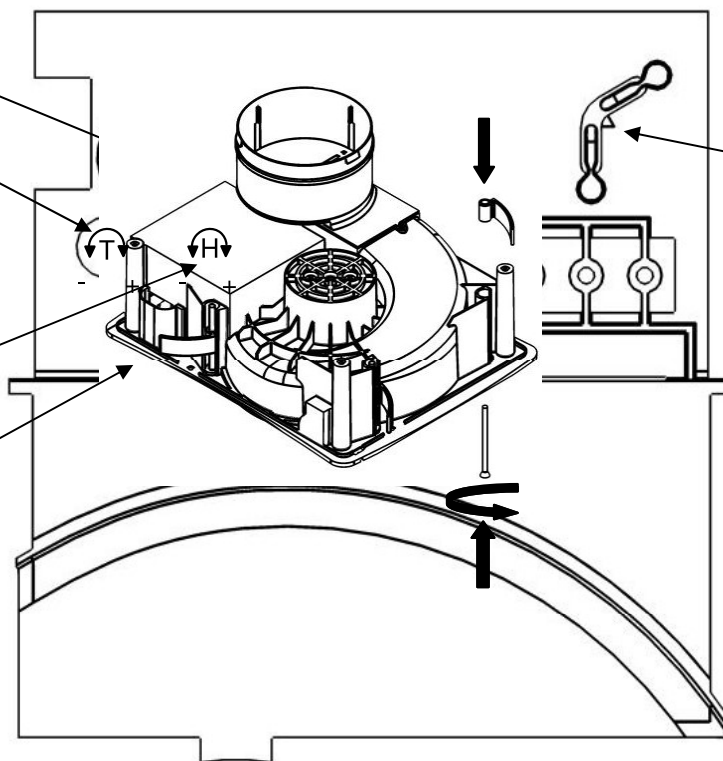

Cable clamp
must be used
with surface
wiring.



IMPORTANT

On first power up, the fan will run through its initialization routine.
On **T**, **HT** & **TM** models the fan will switch on and off during this routine (Including the LED)
Once complete after approximately 2 minutes, the fan will run as normal.

Fig. 8. P/TM wiring diagram

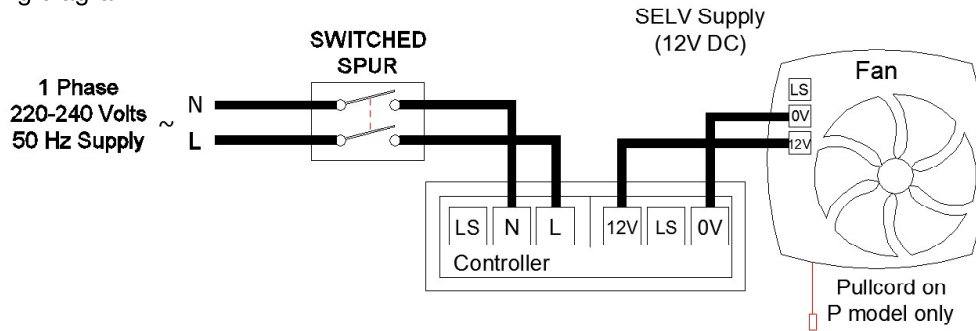
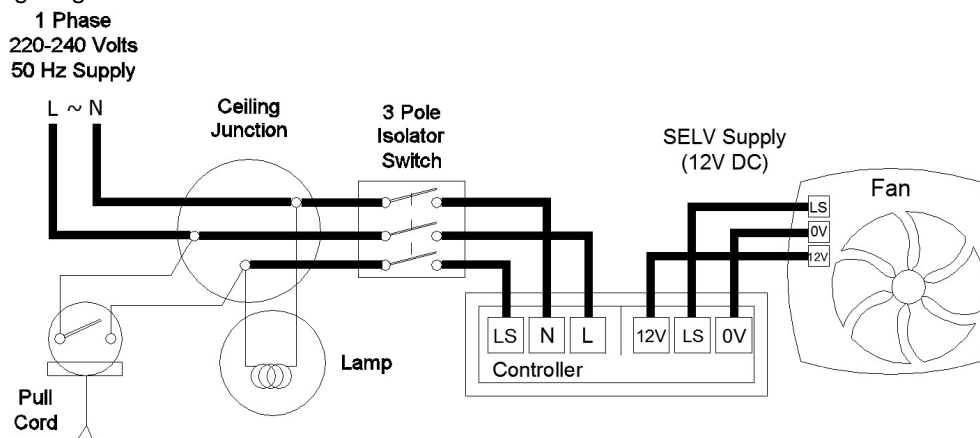

Fig. 9. T/HT wiring diagram



PRODUCT FICHE

For Residential Ventilation Units (Complying Commission Delegated Regulation (EU)

No 1254/2014)

Name:	Vent-Axia	Vent-Axia	Vent-Axia	Vent-Axia
Model ID (Stock Ref.) :	Lo-Carbon Solo Plus SELV P - 427485	Lo-Carbon Solo Plus SELV T - 427486	Lo-Carbon Solo Plus SELV HT - 427487	Lo-Carbon Solo Plus SELV TM - 427488
SEC Class	F	E	C	C
SEC Value ('Average')	13.97	15.72	26.23	26.23
SEC Value ('Warm')	6.32	7.11	11.86	11.86
SEC Value ('Cold')	27.32	30.75	51.31	51.31
Label Required? (Yes/No=Out of scope)	No	No	No	No
Declared as: RVU or NRVU/UVU or BVU	RVU-UVU	RVU-UVU	RVU-UVU	RVU-UVU
Speed Drive	Multi-Speed	Multi-Speed	Multi-Speed	Multi-Speed
Type HRS (Recuperative, Regenerative, None)	None	None	None	None
Thermal Eff: [(%), NA(if none)]	N/A	N/A	N/A	N/A
Max. Flow Rate (m3/h)	75.60	75.60	75.60	75.60
Max. Power Input (W): (@Max.Flow Rate)	8.40	8.40	8.40	8.40
LWA: Sound Power Level (dB)	51.02	51.02	51.02	51.02
Ref. Flow Rate (m3/s)	0.01	0.01	0.01	0.01
Ref. Pressure Diff. (Pa)	N/A	N/A	N/A	N/A
SPI [W/(m3/h)]	0.16	0.16	0.16	0.16
Control Factor & Control Typology: (CTRL/ Typology)				
Control Factor; CTRL	1.00	0.95	0.65	0.65
Control Typology	Manual Control	Clock Control	Local Demand Control	Local Demand Control
Declared: -Max Internal & External Leakage Rates(%) for BVUs or carry over (for regenerative heat exchangers only), -&Ext. Leakage Rates (%) for Ducted UVUs;	N/A	N/A	N/A	N/A
Mixing Rate of Non-Ducted BVUs not intended to be equipped with one duct connection on either supply or extract air side;	N/A	N/A	N/A	N/A
Position and description of visual filter warning for RVUs intended for use with filters, including text pointing out the importance of regular filter changes for performance and energy efficiency of the unit	N/A	N/A	N/A	N/A
For UVUs (Instructions Install Regulated Supply/Extract Grilles Façade)	In F&W	In F&W	In F&W	In F&W
Internet Address (for Disassembly Instructions)	www.vent-axia.com	www.vent-axia.com	www.vent-axia.com	www.vent-axia.com
Sensitivity p. Variation@+20/-20 Pa: (for Non-Ducted Vus)	N/A	N/A	N/A	N/A
Air Tightness-ID/OD-(m3/h) (for Non-Ducted Vus)	N/A	N/A	N/A	N/A
Annual Electricity Consumption: AEC (kWh/a)	2.19	2.03	1.15	1.15
Annual Heating Saved: AHS (kWh/a)				
AHS: Average	13.97	15.72	26.23	26.23
AHS: Warm	6.32	7.11	11.86	11.86
AHS: Cold	27.32	30.75	51.31	51.31

The **Vent-Axia** Guarantee

Applicable only to products installed and used in the United Kingdom. For details of guarantee outside the United Kingdom contact your local supplier.

Vent-Axia guarantees its products for two years from date of purchase against faulty material or workmanship. In the event of any part being found to be defective, the product will be repaired, or at the Company's option replaced, without charge, provided that the product:-

- Has been installed and used in accordance with the instructions given with each unit.
- Has not been connected to an unsuitable electricity supply. (The correct electricity supply voltage is shown on the product rating label attached to the unit).
- Has not been subjected to misuse, neglect or damage.
- Has not been modified or repaired by any person not authorised by the company.

IF CLAIMING UNDER TERMS OF GUARANTEE

Please return the complete product, carriage paid to your original supplier or nearest Vent-Axia Centre, by post or personal visit. Please ensure that it is adequately packed and accompanied by a letter clearly marked "Guarantee Claim" stating the nature of the fault and providing evidence of date and source of purchase.

The guarantee is offered to you as an extra benefit, and does not effect your legal rights

Vent-Axia[®]

Head Office: Fleming Way, Crawley, West Sussex, RH10 9YX.

UK NATIONAL CALL CENTRE, *Newton Road, Crawley, West Sussex, RH10 9JA*

SALES ENQUIRIES: Tel: 0844 8560590 Fax: 01293 565169

TECHNICAL SUPPORT: Tel: 0844 8560595 Fax: 01293 539209

For details of the warranty and returns procedure please refer to www.vent-axia.com or write to Vent-Axia Ltd, Fleming Way, Crawley, RH10 9YX