



# DRI-NOX-KIT-BLUE

# DRI-NOX-KIT-GREEN



## NOX Filter Kit for Drimaster Units Installation and Maintenance

### 1.0 SAFETY INFORMATION

- For installation and maintenance isolate the unit from the power supply.
- Carbon filters/pellets are not to be ingested, ensure hands are thoroughly washed after handling.
- Precautions must be taken to avoid the back-flow of gases into the room from the open flue of gas or other fuel-burning
- To ensure efficient filtration of particulate matter the air filters should be replaced every 5 years as per our recommended maintenance.
- To ensure levels of NO<sub>2</sub> are being reduced, the carbon filters should be replaced every 2 years as per our recommended maintenance.
- If the supply cord is damaged, it must be replaced by the manufacturer, its service agent or similarly qualified persons in order to avoid a hazard.
- This appliance should not be used by children or persons with reduced physical, sensory or mental capabilities or lack of experience and knowledge, unless they have been given supervision or instruction concerning the safe use of the appliance by a person responsible for their safety. Children shall not play with the appliance. Cleaning and user maintenance shall not be carried out by children.

#### 1.1 Personal Protective Equipment

The following minimum PPE (Personal Protective Equipment) is recommended when interacting with Nuaire product:

- **Full Finger Gloves (Marigold PU800 or equivalent)** - when handling sheet metal components or knives. When using silicone, Butyl rubber gloves (0.4mm) are recommended.
- **Safety Glasses** - when conducting any cleaning/cutting operation or exchanging filters.
- **Reusable Half Mask Respirators** - when replacing filters which have been in contact with normal room or environmental air.

Nuaire would always recommend a site specific risk assessment by a competent person to determine if any additional PPE is required.

### 2.0 INTRODUCTION

This filter kit is designed to be retrofitted to existing installed units combining the principles of positive input ventilation and carbon filter technology to improve the quality of the fresh air entering the dwelling.

This kit includes two Carbon valves which can be installed in each inlet alongside the improved ePM10 filter provided.

Nuaire's Carbon Filter has been specifically designed to reduce the level of airborne contaminants entering the property, in particular, nitrogen dioxide (NO<sub>2</sub>), therefore significantly improving indoor air quality (IAQ).

#### 2.1 Code Description

- DRI-NOX-KIT-BLUE** - NOX Filter Kit for use with DRI-ECO units.
- DRI-NOX-KIT-GREEN** - NOX Filter Kit for use with DRIMASTER units.

#### 2.2 Kit Contents

- 2x Formed Mounting Plates (with 4 Metal M4 Inserts)
- 2x Carbon Filter Retainers
- 2x Carbon Filters
- 2x ePM10 - Particulate Filters
- 1x Tube of Silicone
- 4x Self Tapping Screws
- 8x M4 Screws

### 3.0 INSTALLATION

Successful operation of the fan depends entirely upon the unit being installed strictly in accordance with these instructions. Please read through this guide in its entirety before commencing installation and follow step by step to ensure a satisfactory completion.

Whilst the installation of the NOX filters may be achieved by suitable persons, the disconnection of the unit to the mains must be carried out by a qualified electrician.

#### 3.1 Tools Required

- Electric Screwdriver
- Pozidriv Screwdriver Bit
- Knife

## IMPORTANT

The unit **MUST** be isolated from the main supply, before proceeding to work on the unit.

### 3.2 Installing Particulate Filters

- Ensure the working area is well-lit and the unit is placed on a solid surface.
- Remove air filters from the unit by pulling them away from the plastic mouldings at the clipping points.
- To allow good adhesion of silicone, the unit must be clean and free from dust and debris. Clean the air intake on both sides, ensuring the unit is clean and free from dust.
- Ensure the inside of the intake is dry and apply a generous bead silicone around the inside surface of the air intake.
- Insert the mounting plate into the air intake ensuring the cable channel is at the required position (5 o'clock for blue units or 7 o'clock for green units) and aligns with the motor cable. Push the mounting plate into the intake until the top edge is flush with the moulding.
- To ensure a good seal is achieved rotate the mounting plate back and forth a few degrees to spread the silicone. Return the mounting plate with the cable channel to the 5 o'clock position and check the top edge is flush with the moulding.
- Utilising the pre-drilled mounting plate holes, secure the mounting plate to the base unit with an electric screwdriver (Poizdriv bit) and the supplied Poizdriv self-tapper screws (x2). Drilling of the base unit is unnecessary due to the use of self-tapper screws.
- Place the carbon filter over the central hole as seen in Figure 4 and clamp in place using the filter retaining plate. Secure the retaining plate using the four domed screws provided.
- Refit the particulate filters by clipping the metal hoop of the particulate filter back into the moulded clips.
- Repeat process for the remaining air inlet of the unit.

### 3.3 Minimum Speed Label

A label informing the end user of the minimum speed setting of 3 is provided with the NOX filter kit. Ensure this label is fitted in close proximity to and within view of the unit speed control.

## IMPORTANT

Carbon filters / pellets are not to be ingested and hands are to be thoroughly washed after handling.

#### 1 Removing Particulate Filters

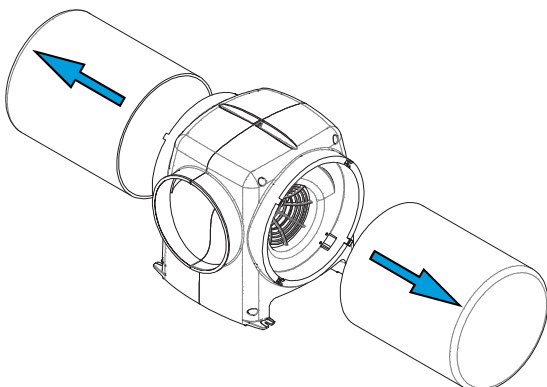

#### 2 Applying Silicone Bead

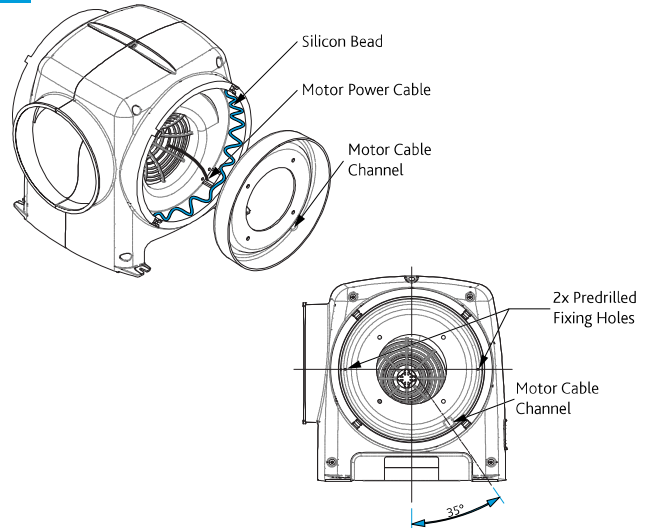

#### 3 Spreading Silicone

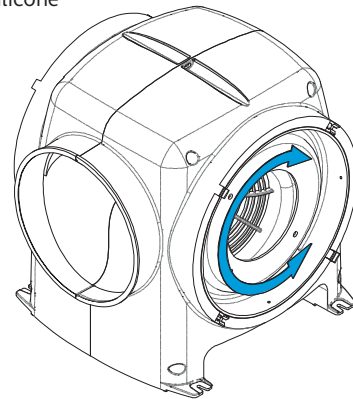

#### 4 Fitting Carbon Filters

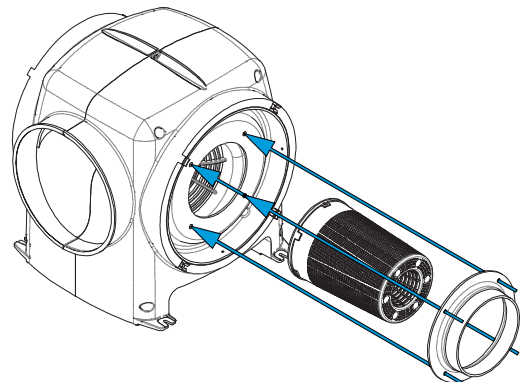

#### 5 Fitting Particulate Filters

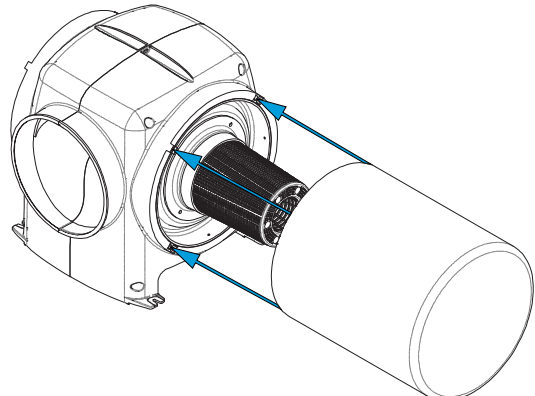

3.4 Speed Settings

Both the DRI-ECO (BLUE unit) and the DRIMASTER (GREEN unit) products have 6 speed settings. Due to the increased resistance of the carbon and ePM10 filters only speeds 3-6 should be used. If the unit is currently set to speed 1 or 2 increase to the minimum required speed of 3.

The speed controls of the units are located on the unit diffuser for DRI-ECO (BLUE) and at the base unit for the DRIMASTER (GREEN).

The following table shows the flow rates and their corresponding speed settings e.g. a 1 bedroom property should be set to speed 1, whereas a 4 bedroom property would require speed 6.

DRI-ECO with Carbon and ePM10 Air Filters	
Speed	Air Flow Rate (l/s)
1	5
2	11
3	18
4	25
5	33
6	41

**IMPORTANT**

When carbon filters are installed a minimum speed setting of 3 is required.

3.5 Temperature Control Settings

As default units are set to temperature setting 1.

3.5.1 Temperature Control Setting for DRI-ECO (Blue Units)

To change this setting, switch the power to the unit off and on via a safe method. The display in the ceiling vent will show the start-up pattern for two minutes and the unit will be running at speed 6. In this time you can change the temperature setting by pressing and holding the "up" switch. The display will show a flashing value of 1 and will increase every 4 seconds. Once you have reached the temperature setting you require press and release the "down" button to store the setting. The fan will now enter into its normal speed setting mode and a speed can be selected at this point.

**IMPORTANT**

For the best Indoor Air Quality Nuair recommend that units are running continuously in mode 3 (radon mode)

Option	Temperature Control Description
1 (Default)	At loft temperatures below 19°C the unit will operate on "Normal Operation Mode". At loft temperatures above 18°C but less than 24°C, the unit will switch automatically to "Intelligent Heat Recovery Mode". At loft temperatures above 23°C the unit will switch itself automatically to "Standby Mode".
2	At loft temperatures below 19°C the unit will operate on "Normal Operation Mode". At loft temperatures above 18°C but less than 31°C, the unit will switch automatically to "Intelligent Heat Recovery Mode". At loft temperatures above 30°C the unit will switch itself automatically to "Standby Mode".

Option	Temperature Control Description
3 (recommended)	This option removes the temperature sensing function out of the unit. The unit will operate continuously in "Normal Operation Mode" depending on the volume control setting selected.
4	At loft temperatures below 16°C the unit will operate on "Normal Operation Mode". At loft temperatures above 15°C but less than 28°C, the unit will switch automatically to "Heat Recovery Mode". At loft temperatures above 27°C the unit will switch itself automatically to "Standby Mode".
5	Not applicable for the HEAT model.

3.5.2 Temperature Control Setting for DRIMASTER (Green Units)

When power to the unit is switched on (via the isolator) the 3 LED's will flash simultaneously and the unit will function at boost speed for a period of 2 minutes (allowing the installer time to move between the isolator and DRIMASTER prior to the unit starting on its default setting).

With the LED's still flashing, press the hold the setting button. With the unit running through its start-up sequence (indicated by the LED's changing every 4 seconds) you can select the temperature control function removing your finger from the button when the centre and right hand LED's are both illuminated.

6 LED's showing Temperature Control function

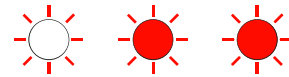

To select the option required (Figure 7), scroll through the Control Options until the desired option is illuminated. Now SWITCH OFF at isolator and wait for the LED's to extinguish (approximately 10 seconds) then SWITCH ON. This action stores the chosen option in the unit's memory.

7 LED's showing Temperature Control Options

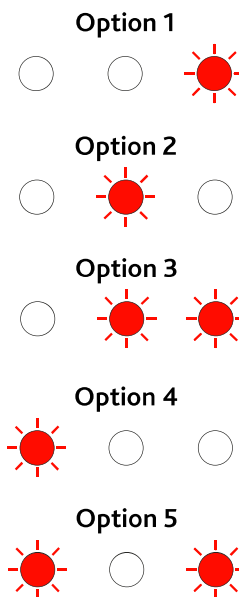

## 4.0 MAINTENANCE

It is important that maintenance checks are recorded and that the schedule is always adhered to, in all cases, the previous report should be referred to. Failure to maintain may impair the performance and efficiency of this unit.

- Change carbon filters every 2 years, failure to do so may impair the performance and efficiency of this unit.
- As standard, each unit is supplied with G3 particulate filters which require replacing every 5 years. If the unit in question has been supplied with the ePM10 filters, they should be visually checked every 2 years and changed every 5 years as a minimum. The unit display will show the letter 'C' once this time has elapsed.

## 5.0 WARRANTY

Filter replacement is not covered by the unit warranty.

## 6.0 END-OF-LIFE AND RECYCLING

Where possible Nuaire uses components which can be largely recycled when the product reaches its end-of-life:

- Fans, motors, controls, actuators, cabling and other electrical components can be segregated into WEEE recycling streams.
- Sheet metal parts, aluminium extrusion, heating/cooling coils and other metallic items can be segregated and fully recycled.
- EPP, plastic ducting, nylon corner pieces, plastic heat exchangers, packaging material and other plastic components can be segregated into mixed plastic and widely recycled.
- Cardboard packaging, wood, used filters and other paper components can be largely recycled or fully processed in energy from waste centres.
- Disposal of Carbon Filters can be arranged via Nuaire, contact the After Sales department for more information.
- Remaining Items can be further segregated and processed in accordance with the zero waste hierarchy. Please call After Sales Support for further information on items not listed above.

## 7.0 AFTER SALES AND REPLACEMENT PARTS

For technical assistance or further product information, including spare parts and replacement components, please contact the After Sales Department.

If ordering spares please quote the serial number of the unit together with the part number, if the part number is not known please give a full description of the part required. The serial number will be found on the identification plate attached to the unit casing.

Telephone 02920 858 400  
aftersales@nuaire.co.uk

AVAILABLE NOW FROM  
**i-sells.co.uk**



Showroom:  
15 St John's Parade  
Sidcup High Street  
DA14 6ES

EMAIL: sales@i-sells.co.uk  
SALES: 020 8463 9696  
WEB: www.i-sells.co.uk