

Calm Design Fan Series

Features

- Specially designed mixed-flow impeller ensures high airflow and low noise level.
- Built in backdraft damper.
- Suitable for installing within bathroom zones 1 and 2.*
- Complies with part L and part F of the Building Regulations.
- 5 year warranty.



Air Capacity:
up to 90 m³/h
25 l/s



Specific Fan Power (SFP):
Down to 0.3 w/l/s.



Sound Pressure Level:
From 26 dB(A).



Model Code	Size	Airflow [l/s]	Noise [dB(A)]	Control	Shutter	IP Rating	SFP [w/l/s]
CALM DESIGN 100	100mm	25	26	Standard	✓	45	0.3
CALM DESIGN 100 S	100mm	25	26	Pull-Cord	✓	45	0.3
CALM DESIGN 100 T	100mm	25	26	Run-on Timer	✓	45	0.3
CALM DESIGN 100 ST	100mm	25	26	Pull Cord & Timer	✓	45	0.3
CALM DESIGN 100 H	100mm	25	26	Humidity Sensor	✓	45	0.3
CALM DESIGN HI-TECH 100	100mm	25	26	Standard	✓	45	0.3
CALM DESIGN HI-TECH 100 S	100mm	25	26	Pull-Cord	✓	45	0.3
CALM DESIGN HI-TECH 100 T	100mm	25	26	Run-on Timer	✓	45	0.3
CALM DESIGN HI-TECH 100 ST	100mm	25	26	Pull-Cord & Timer	✓	45	0.3
CALM DESIGN HI-TECH 100 H	100mm	25	26	Humidity Sensor	✓	45	0.3

Dimensions

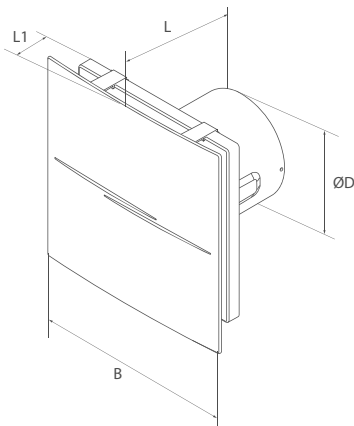

Model Code	Dimensions [mm]				
	ØD	B	H	L	L1
CALM 100	99	158	136	81	26
CALM 125	123.5	182	158	91	27
CALM 150	147.5	214	190	111	32