

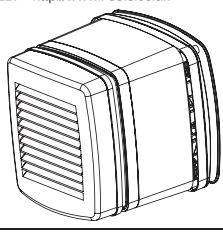

Model: NUACYFAN-WKIT
Quick Search: QS45737



CYFAN Extract Fans

Window Mounting Kit (CYFAN-WKIT)

Installation and Maintenance

CE The EMC Directive
2004/108/EC
The Low Voltage
directive
2006/95/EC

CYFAN Window Mounting Kits

The Nuaire CYFAN Window Kit contains the following parts. Make sure you have all the parts present before commencing installation.

Parts Checklist CYFAN-WKIT	Part No.
1 off Window Cover	041351
1 off Outside Clamp	041350
1 off 'O' ring assembly	691645
1 off Inner Clamp	041349
1 off 'O' ring assembly	691645
2 off Backdraught Shutter	041286
1 off Screw Kit containing Shutter Spring	772285

Parts Checklist SCREW KIT-772285	Part No.
2 off No.8 x 1" CSK HD Supascrew	691646
4 off No.8 x 1-1/2" CSK HD Supascrew	680193
4 off No.8 x 1-3/4" CSK HD Supascrew	691647
2 off No.8 x 2-1/4" CSK HD Supascrew	691648
3 off No.8 x 3/4" Panhead Pozi (Main Case to Inner Clamp)	180394
1 off Spring	580069

The window kit is designed for mounting the unit into windows 4mm to 32mm thick using a 125mm dia. hole in the glass. (see fig 1.)

Fig 1.

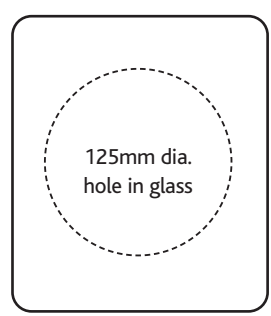

- Employ a qualified glazier to cut a hole 125mm dia in the glass or, alternatively, replace your window with new glass incorporating a pre-cut hole.
- The outer assembly consists of a cover complete with clamping plate and an 'O' ring seal. The clamping plate incorporates a moulded spigot which is designed to locate inside the 125mm dia hole in the glass.
- Back draught Shutters Fig 2. are clipped into Inner Clamp and the spring is fitted in the lower position.

- Position the assembly on the outside of the glass. If only one person is installing the fan it may be helpful to tape the assembly to the outside glass at this stage during installation as all fixings and assembly are completed from inside.
- Working from inside the room with the clamp. Position this inner clamp over the hole in the glass and line up the 4 mounting holes.

6. Select appropriate screws from the screws kit supplied for mounting into different thicknesses of glass, see table below.

Window mounting Screws

Window thickness	Screw size
2 off 4mm - 11mm	No8 x1" CSK HD
2 off 12mm - 21mm	No8 x1-1/2" CSK HD
2 off 22mm - 32mm	No8 x1-3/4" CSK HD
2 off	No8 x2-1/4" CSK HD

Should the screws foul on the back of the grille during installation replace with the next size down. There are 2 long and 2 short screws for each thickness of glass, the shorter screws are at the top.

7. Using four screws locate with the screw bosses in the outer assembly, draw the inner and outer assemblies together.

Fig 2. Spring assembly.

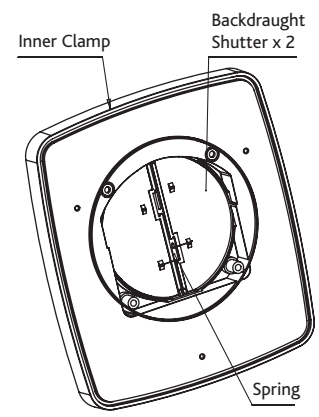

Remove any tape supporting the outer assembly and continue to draw the units together until the 'O' ring is compressed on the window. Note: do not over tighten the fixing screws as this may distort the assembly.

8. Wire unit in accordance with the appropriate wiring diagram. A cable clamp is provided inside the case. Note: the remaining installation procedures for Window Mounting are as Surface Mounting description in installation document 671629.

Fig 3. Kit components.

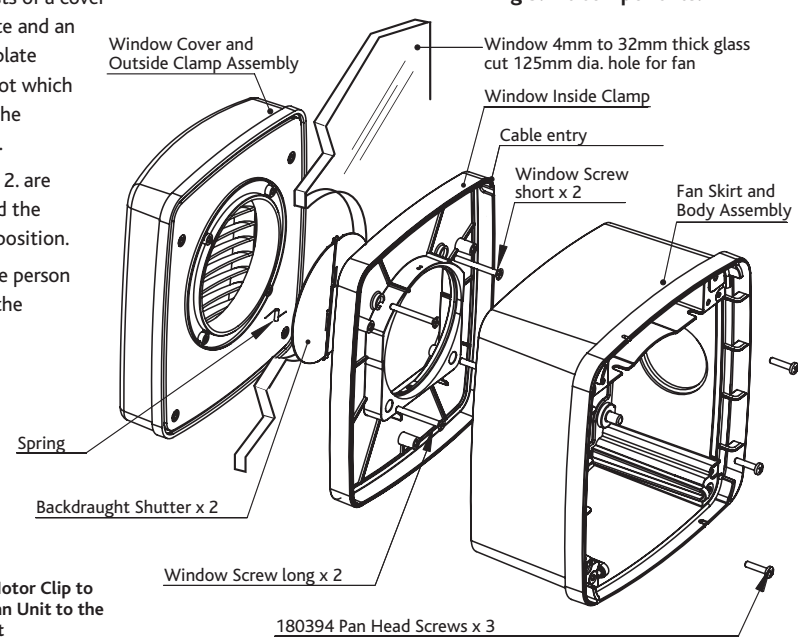

*Remove Motor Clip to fix the Cyfan Unit to the Window Kit