



DRI-ECO-3STOREY

Anti-Condensation and Whole House Ventilation Unit Installation and Maintenance

CE The EMC Directive
2014/30/EU
The Low Voltage
Directive
2014/35/EU

1.0 INTRODUCTION

The DRI-ECO-3STOREY provides whole home ventilation using the Positive Input Ventilation principle. The concept is to introduce fresh, filtered air into the dwelling at a continuous rate, encouraging movement of air from inside to outside.

To achieve this the unit is mounted in the loft space, drawing air through the filters and inputting it, at ceiling level, into the property.

The DRI-ECO-3STOREY fan unit includes an internal sensor to regulate the fan speed according to the temperature of the loft. The internal sensor is to increase airflow to the dwelling when the loft is warmer than the house. The units 'Fixed Temperature Heat Recovery' strategy shall be achieved via a sensor located in the unit and shall improve energy performance accordingly. The aluminium ceiling vent supplied includes an intumescent closure element.

Once installed, the airflow can be set to suit the house size and, if required, the way it responds to the temperature changes within.

2.0 IMPORTANT NOTES TO INSTALLERS

Successful operation of the fan depends entirely upon the unit being installed strictly in accordance with these instructions. Please read through this guide in its entirety before commencing installation and follow step by step to ensure a satisfactory completion. Whilst the installation of the DRI-ECO-LC unit may be achieved by suitable persons, the provision of the electrical supply and the connection of the unit to the mains must be carried out by a qualified electrician.

Warning: Isolate from power supply before removing any covers. During installation/maintenance ensure all covers are fitted before switching on the mains supply.

This appliance can be used by children aged from 8 years and above and persons with reduced physical, sensory or mental capabilities or lack of experience and knowledge if they have been given supervision or instruction concerning use of the appliance in a safe way and understand the hazards involved. Children shall not play with the appliance. Cleaning and user maintenance shall not be made by children without supervision.

Precautions must be taken to avoid the back-flow of gases into the room from the open flue of gas or other fuel-burning appliances.

Means for disconnection must be incorporated in the fixed wiring as shown in the wiring diagram in accordance with IEE wiring or national wiring rules.

CAUTION: In order to avoid a hazard due to inadvertent resetting of the thermal cut-out, this appliance must not be supplied through an external switching device, such as a timer, or connected to a circuit that is regularly switched on and off by the utility.

3.0 LOFT INSPECTION

Check to ensure that the loft has adequate ventilation. There may be occasions where a loft is so well sealed that additional ventilation may have to be provided by the owner/occupier.

Ensure that all water tanks are covered and sealed.

Check that all water pipes are lagged.

Ensure that any extract fans are discharging to outside and not into the loft.

Check that the loft hatch is tightly sealed.

Ensure that all holes in the ceilings are sealed i.e. ceiling light fittings etc. A visual inspection of any flues or chimneys for leakage in the loft should be carried out by the installer.

If any leakage points are found, or if there is any doubt at all, then the installer should advise the house owner/provider as soon as possible and seek instruction from them before proceeding with the installation.

4.0 DIFFUSER INSTALLATION

4.1 Siting the Diffuser Position

The diffuser has a unique air throw pattern and it is essential that it is located correctly in the central hallway in single storey properties or in the ceiling of the top floor landing on 2 or more storey dwellings.

The diffuser discharges air from 2 sides along the underside of the ceiling.

Speed Setting	Minimum distance of diffuser from wall
1	100mm
2	155mm
3	400mm
4	625mm
5	850mm
6	1000mm

Note: SMOKE ALARMS -It is also important to ensure that the diffuser is NOT placed within 1 metre of a smoke alarm.

If the diffuser cannot be repositioned, the diffuser must be positioned so as to encourage the air through the 2 open sides that face at least 1.5 metres of unobstructed area away from the smoke alarm sensor.

4.2 Fitting the Aluminium Diffuser (c/w Intumescent Fireblock)

Cut a 200mm hole in ceiling and align the top portion of unit (A) above the ceiling over the hole. Position the central ceiling plate (B) on the ceiling in the room ensuring the the central hole is aligned with the hole in the ceiling. Use the 4 screws to fix (B) to (A) through the 4 studs positioned on the upper side of (B). Screw bottom part of the unit (C) to the the ceiling plate (B) through the plastic spacers and into the 2 studs positioned on the upper side of (A).

Note: Due to the higher air resistance of the fireblock, the speed of the unit should be increased by one increment for the particular property (see 9.1 speed settings).

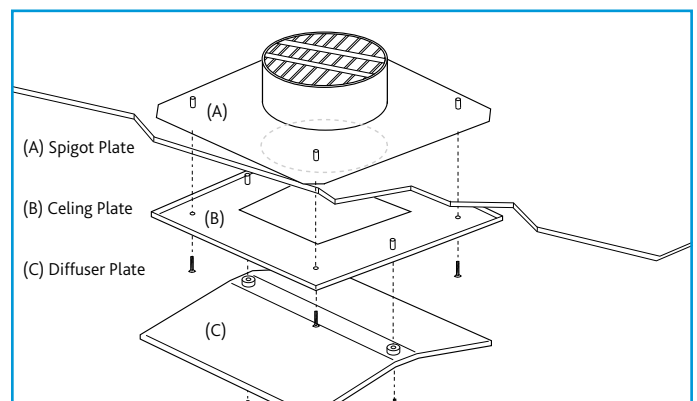

DRI-ECO-LC - Installation and Maintenance



5.0 FITTING THE FILTERS

The filter has a push fit rim to attach itself to the main body of the unit. Offer the filters up to the unit and apply a small amount of pressure to the filters rim (by hand). The filter will clip into place.

The unit can then be attached to the roof via the cord provided (or fixed to the floor joists using the optional anti vibration mounting kit).

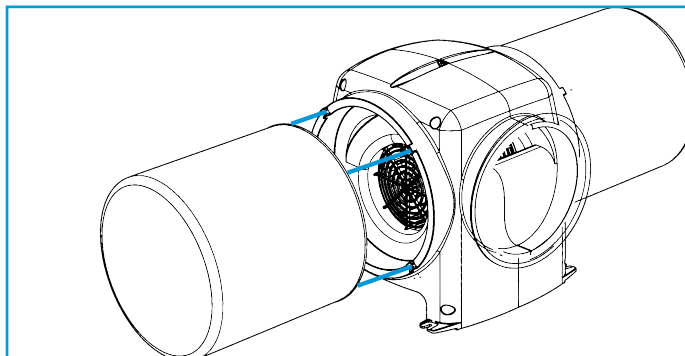

6.0 DRI-ECO-3STOREY INSTALLATION

6.1 Joist Hung (Standard Mounting)

The standard method of installation is to suspend from a convenient roof beam via the cord supplied (Note: unit weight = 3.5 kg). The method of locating the cord to the roof timber is the responsibility of the installer.

The flexible duct (maximum length 2m) is connected to the fan unit by inserting the duct over the fan outlet and held in place using the supplied cable tie. This method is repeated when connecting the duct to the ceiling vent. Note: Ensure all duct joints are airtight.

Please note: The flexible ducting should NOT be installed in a compressive state, as this will negatively impact on the performance of the unit.

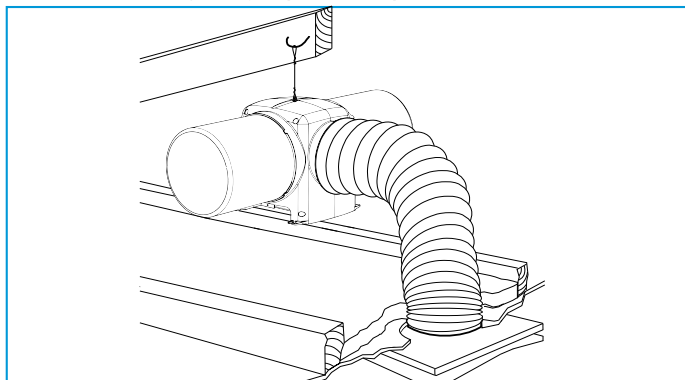

6.2 AV Mounting (Optional)

The AV kit contains all the parts necessary to complete a joist mounted installation. If AV mounting is required the kit can be purchased direct from Nuaire using the following code number: **771393**.

Lower the unit with battens (battens are not supplied by Nuaire) attached onto the joists. Mark and drill the 12mm dia. clearance holes required in the ends of the battens.

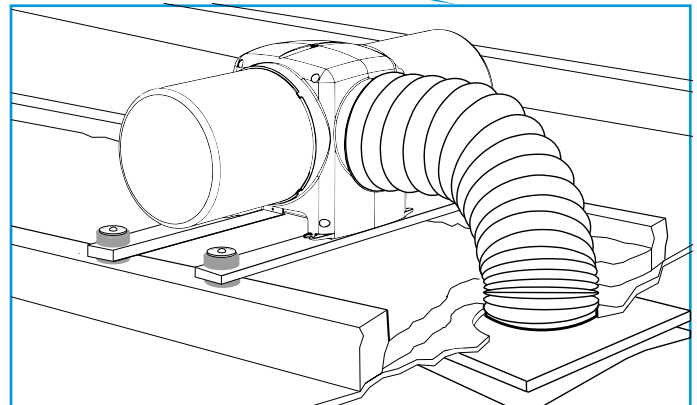

Place anti-vibration mounts above and below each batten fixing point and, using the 4 large screws and special washers, fix the unit to the joists.

Do not overtighten the fixings. The distance from the top washer to the joist when installed must not be less than 50mm.

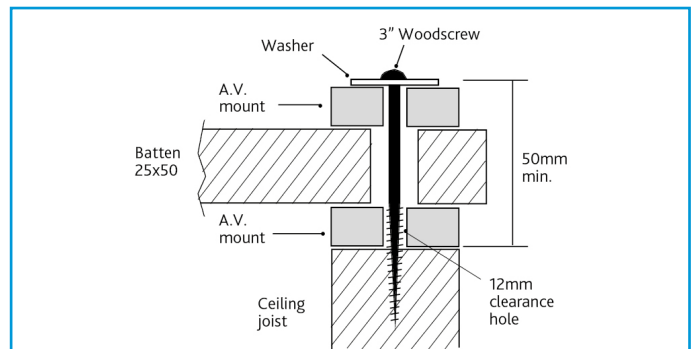

7.0 ELECTRICAL CONNECTION

Please note: the electrical connection of the unit must be carried out by a qualified electrician.

Electrical details:-

Voltage: 230V 1ph 50Hz

Consumption: 1.6W(min) 15.3W(max)

Fuse size: 1 Amp

The unit is supplied with a pre-wired power supply. This power supply unit has a metal bracket incorporating fixing holes, which should be used to fit the power supply to a suitable surface e.g. a wooden joist.

The fan unit is also supplied with a fused spur. The two core mains cable from the power supply should be connected to a fixed wiring installation, via the spur, in accordance with current IEE wiring regulations.

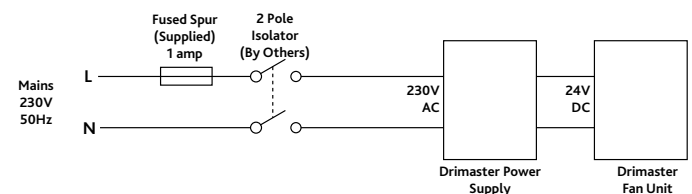

Disconnection from mains must be incorporated within the fixed wiring and shall have a maximum contact separation of 3mm in accordance with latest edition of the wiring regulations.

8.0 SMOKE / CARBON MONOXIDE ALARM AUTOMATIC SHUT DOWN

If the unit is required to switch off in the event of smoke/CO detection, alarms are available with separate relay bases from companies such as:

Dicon Safety products – www.diconsafety.co.uk

Aico Ltd – www.aico.co.uk

Note: This is a mandatory requirement for all units installed in a 3 Storey property.

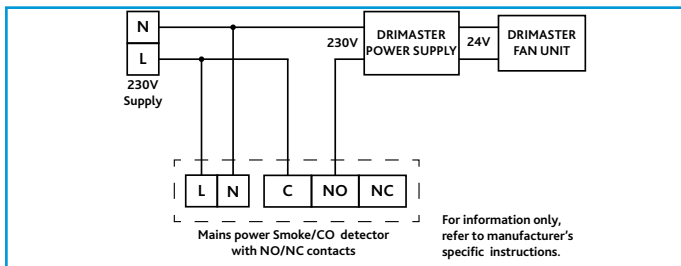

IMPORTANT

For good EMC engineering practice, the DRI-ECO-LC power supply output cable and any sensor cables should not be placed within 50mm of other cables or each other.

9.0 CONTROL SETTINGS

9.1 Speed Settings

The unit has 6 air flow rate (speed) settings, 1-6. Switches to control the speed settings and the display are located on the rear of the fan unit. The following table shows the flow rates and their corresponding speed settings.

As an example a one bedroom bungalow should be set to speed 1, and a large 5 bedroom detached property would require speed 6.

Speed Settings	Air flow rate (Litres/second)
0	Standby (0)
1	10
2	20
3	30
4	40
5	50
6	60

9.2 Selecting a Speed

When power to the unit is switched on the display will show the temperature control option for 2 minutes. Once the start-up pattern has completed you may now press the "up" or "down" switch to choose the flow rate appropriate to the property you are installing the unit in.

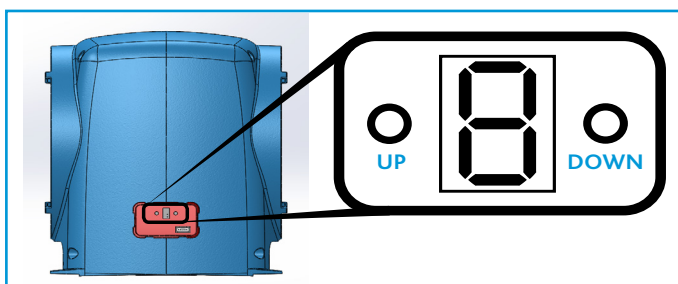

9.3 Setting the Temperature Control Option

When delivered, the unit is set to temperature setting 1 as a default. To change this setting, switch the power to the unit on. The display on the rear of the fan unit will show the temperature control option for 2 minutes and the unit will be running at speed 6. In this time you can change the temperature setting by pressing and holding the "up" button. The display will show a flashing value of 1 and will increase every 4 seconds. Once you have reached the temperature setting you require press the "down" button to store the setting. The fan will now enter into its normal speed setting mode and a speed can be selected at this point.

Option	Temperature Control Description
1 (Default)	At loft temperatures below 19°C the unit will operate on "Normal Operation Mode" . At loft temperatures above 18°C but less than 24°C, the unit will switch automatically to "Intelligent Heat Recovery Mode" . At loft temperatures above 23°C the unit will switch itself automatically to "Standby Mode" .
2	At loft temperatures below 19°C the unit will operate on "Normal Operation Mode" . At loft temperatures above 18°C but less than 31°C, the unit will switch automatically to "Intelligent Heat Recovery Mode" . At loft temperatures above 30°C the unit will switch itself automatically to "Standby Mode" .
3	This option removes the temperature sensing function out of the unit. The unit will operate continuously in "Normal Operation Mode" depending on the volume control setting selected.
4	At loft temperatures below 16°C the unit will operate on "Normal Operation Mode" . At loft temperatures above 15°C but less than 28°C, the unit will switch automatically to "Intelligent Heat Recovery Mode" . At loft temperatures above 27°C the unit will switch itself automatically to "Standby Mode" .
5	At loft temperatures below 19°C the unit will operate on "Normal Operation Mode" . At loft temperatures above 27°C or below 5°C the unit will switch itself automatically to "Standby Mode" . Notes: Speed Setting 1 is not available for Temperature Control Option 5. On selecting Temperature Control Option 5, Speed Setting 1, the unit will operate as Speed Setting 2.

10.0 FILTER MAINTENANCE AND REPLACEMENT

The filters are required to be changed every five years, the display will show the letter 'C' once this time has elapsed. New filters can be purchased direct from Nuair using the following code number: **DRIP0S2001-FILTERKIT** (five year filter). To reset the change filter message, press and hold BOTH "up" and "down" button for between 10-20 seconds, then release, the letter 'C' starts to flash, press the "down" button.

Note: If the units' performance has been reduced dramatically or black dust becomes visible around the outlet diffuser, check that the filter has not become dislodged in any way.

11.0 FREQUENTLY ASKED QUESTIONS

While very rare, issues with newly installed units can occur. Typically these issues can be easily solved by referring to the below table.

Symptom	Cause	Solution
Fan not running.	NO power to the unit (Display is NOT lit).	Ensure unit has not been switched off or that the local fuse has not blown.
	Software error - Power to the unit (Display is lit).	If electricity present, power off, wait and power on again – this may restart the unit.
	Fan failure - Power to the unit ('F' is flashing on display).	Fan has failed and a replacement unit is required.
	High loft temperature.	This is normal, see temperature control options.

12.0 WARRANTY

The unit has a 5 year warranty starting from the day of delivery and includes parts and labour for the first year. The remaining 4 years covers parts only. This warranty is conditional on the following:

- a) That the unit is installed strictly in accordance with this guide.
- b) That the unit filters are removed and cleaned or replaced at the recommended intervals.
- c) Where a floor/room is more than 4.5m tall, the fan unit must be fitted with a 3 storey aluminium diffuser and requirements in section 8.0 followed.

13.0 SPARES & SERVICE ENQUIRIES

Spare parts and replacement components are available from Nuaire Ltd. Please contact us for further details.

Our Technical Support department will be happy to provide any assistance required, initially by telephone and if necessary, arrange for an engineer to call.

Telephone 029 2085 8400
technicalsupport@nuaire.co.uk