

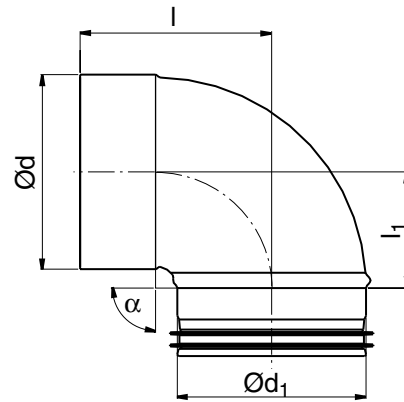

Bend – Casting-in programme BKMU 90°



Dimensions



Ød ₁ nom	Ød mm	l mm	l ₁ mm	m kg
80	80	123	80	0,13
100	100	105	62	0,21
125	125	120	79	0,31
160*	160	136	94	0,63

* With a seam in the middle

Description

Pressed and seam welded bend with short installation length and female end.

Ordering example

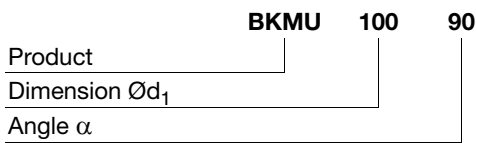

Technical data

