

Grilles, Louvres, Diffusers & Air Valves

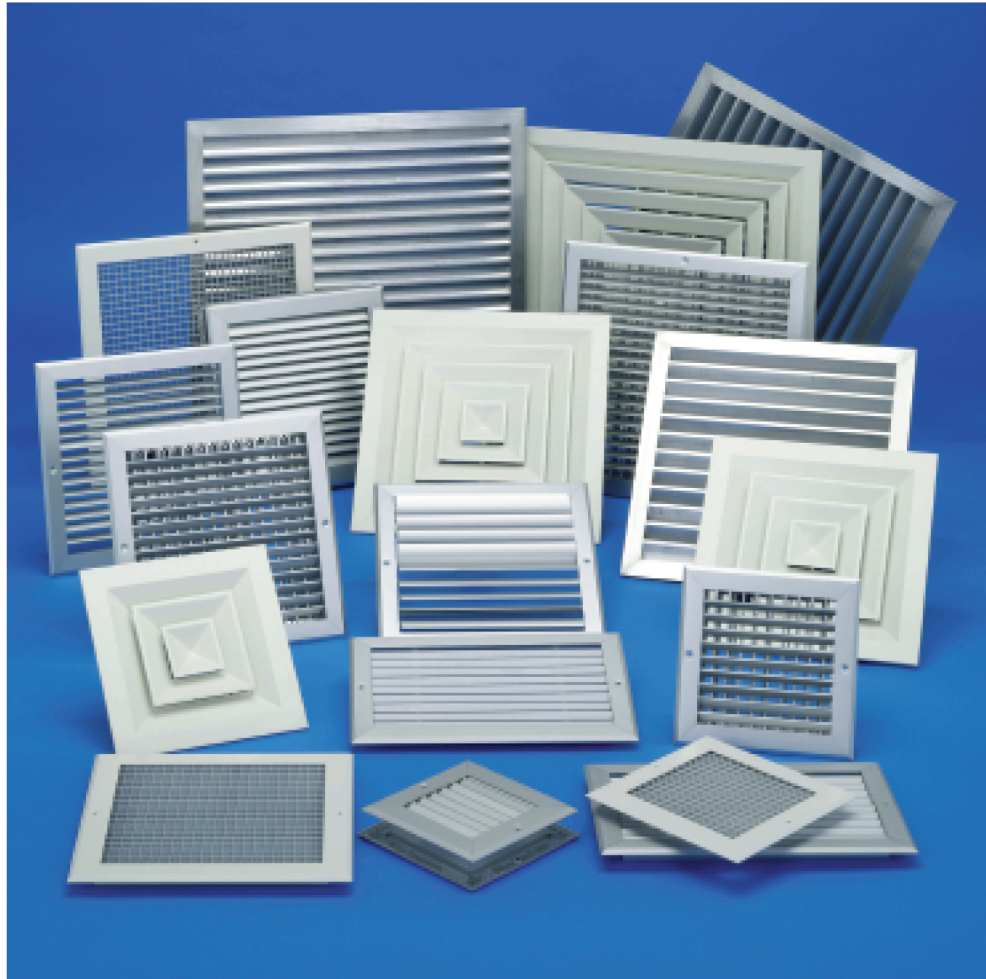

- Polyester powder coated white and silver finishes as standard.
- Extensive range of stock product lines.
- Quality assured product range.
- Special BS and RAL colours available to order.
- Air Valves and Spiral Duct Grilles complete the range.

Single Deflection Grilles - Type SD



Single deflection grilles have a single row of individually adjustable horizontal blades. They are suitable for sidewall supply & extract in a wide range of applications. A centre supporting mullion is fitted to all grilles over 400mm to ensure rigidity.

Quality

The quality of our products and service have always been of great importance to us. Lindab is a quality assured company and is accredited to BSEN ISO 9001: 2000.

Construction

grilles & diffusers are manufactured from high quality materials throughout with mechanically locked mitred face corners which provide a well engineered joint combined with excellent visual appearance.

Finish

All grilles & diffusers are polyester powder coated to provide a high quality, tough and attractive finish in white (RAL 9010 semi-gloss). Non vision transfer grilles are supplied in a satin silver finish as standard.

The satin silver finish is also available as a no cost option on all grilles.

Weather louvres and dampers are supplied mill finish.

Fixing

Standard products are supplied with countersunk fixing holes in the border, complete with colour matched fixing screws (NOTE: CD diffusers, tile replacement eggcrate grilles & weather louvres do not have face fixing holes).

Packaging

All products are individually shrinkwrapped and fitted with removable oversized plastic corner pieces to protect the grill/diffuser face & corners in transit (circular ceiling diffusers are individually suitably wrapped for transit).

Options

Paint Finish - In addition to the standard finishes virtually any RAL or BS colours maybe specified at extra cost.

Dampers - All products (ex. weather louvres) can be supplied complete with an opposed blade damper.

Plenum Boxes - Are available in both high impact polystyrene & galvanised sheet steel. Being lighter our plastic boxes are easier to install, are generally available from stock and offer significant cost benefits.

Ordering Procedure

When ordering please give the nominal duct aperture into which the product is to be offered (for ceiling diffusers give the neck size). These are the dimensions used as standard. Give the width dimension first, followed by the height.

A manufacturing size 'reduction' tolerance is provided to ensure a good fit. If the 'overall' size is critical please order by these dimensions clearly stating 'overall size'.

Blades on grilles always run width dimension.

Technical Data

Product selection data available on request.

Single Deflection Grille with Damper

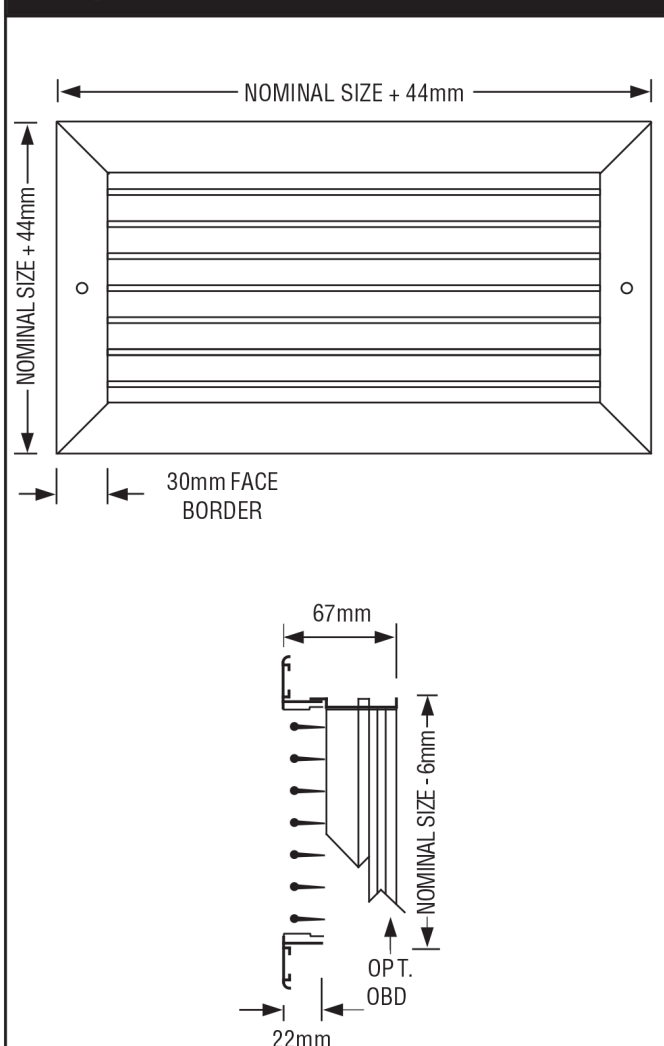

Free Area: Approx 75%.

Double Deflection Grilles - Type DD

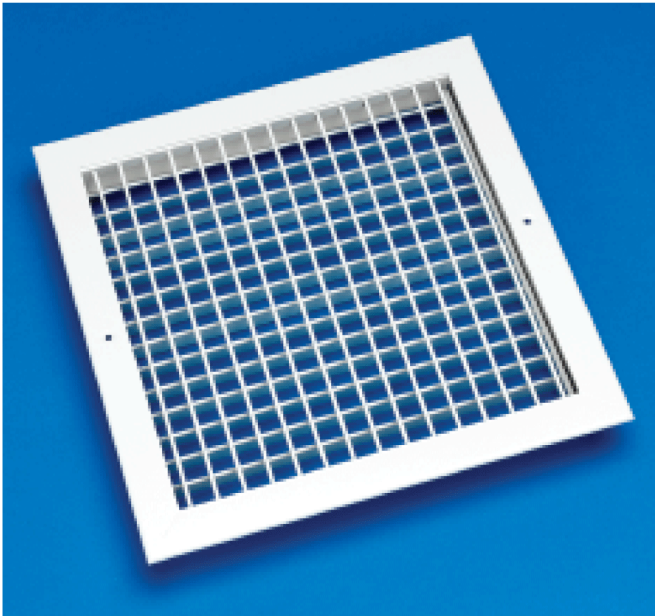

Double deflection grilles have a front row of individually adjustable horizontal blades and behind them a secondary row of vertical adjustable blades. Suitable for supply applications in both sidewalls and ceilings. A centre supporting mullion is fitted to all grilles over 400mm to ensure rigidity.

Eggcrate Grilles - Type EC

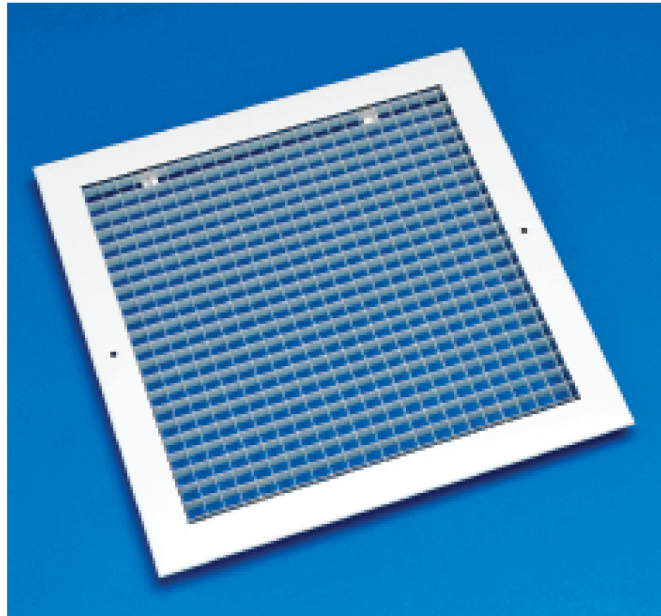

Eggcrate grilles have a 13mm x 13mm square core and with their high free area are ideal for return air applications. Supplied as standard with countersunk holes for fixing (except 595 x 595 overall 'tile replacement' sizes). Eggcrate grilles with removable or hinged cores and disposable filter panel are available to special order.

Double Deflection Grille with Damper

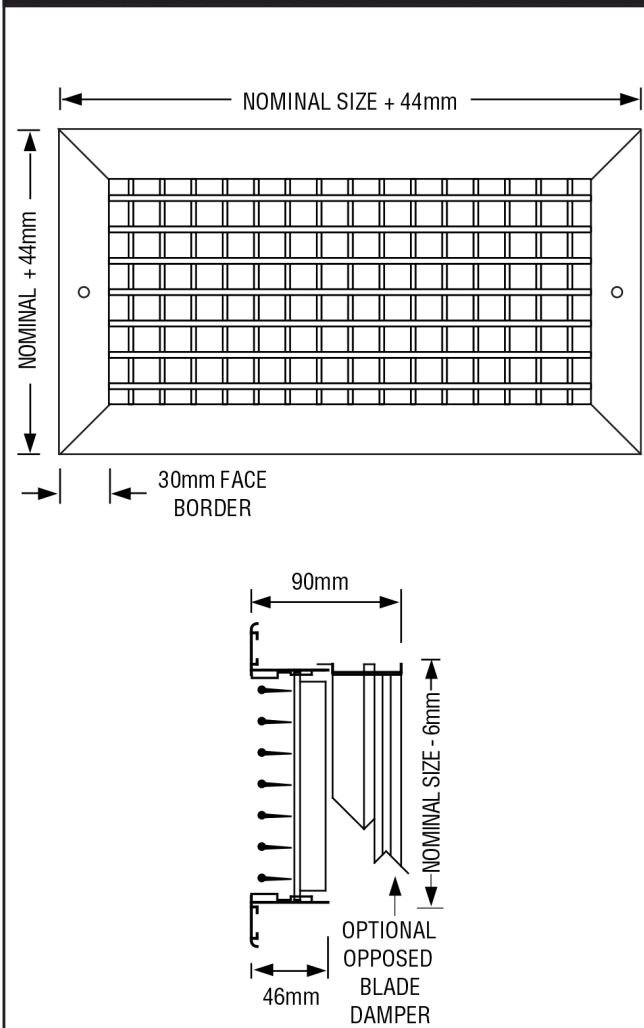

Free Area: Approx 75%.

Eggcrate Grille with Damper

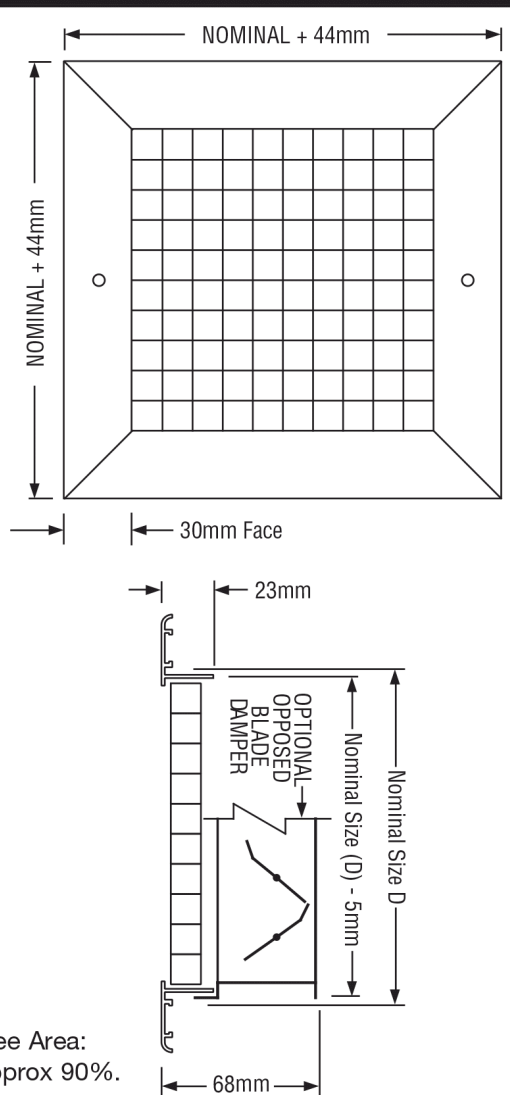

Free Area:
Approx 90%.

Product selection data available on request.

Curved Blade Grilles - Type CB



Curved blade grilles are available in 1, 2, 3 or 4 way air diffusion patterns. They have one set of individually adjustable blades. One & two way blow have blades running parallel to the width dimension. A centre supporting mullion is fitted to all grilles over 600mm.

Non Vision Grilles - Type NV

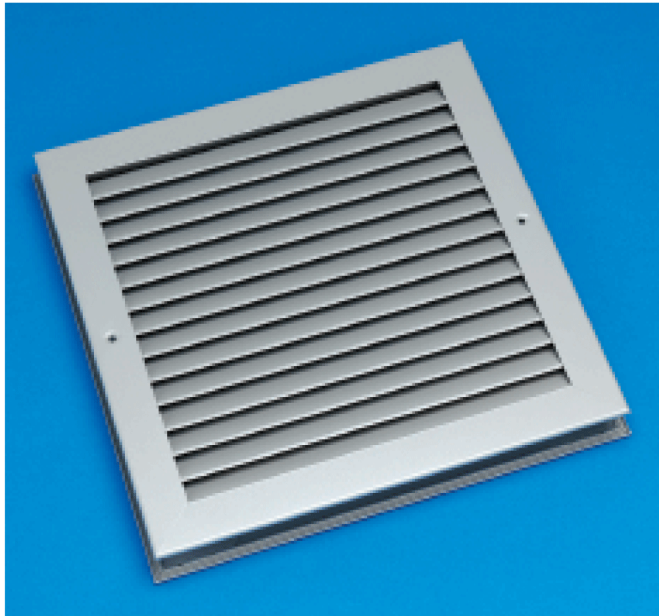

Non vision grilles are manufactured with a fixed inverted V profile to provide a vision proof air transfer grille. Non vision grilles are available as a single unit or with matching flange as shown below (suitable for door/wall thicknesses of 36-60mm). Polyester powder coated silver finish as standard.

Curved Blade Grille with Damper

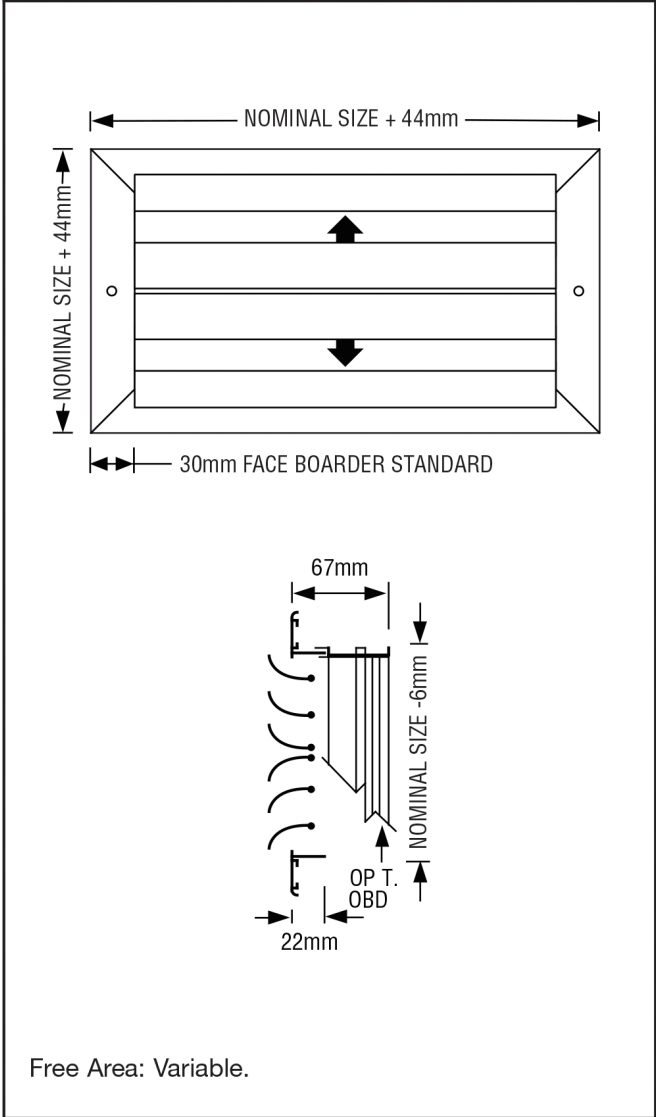

Non Vision Grille with matching Flange

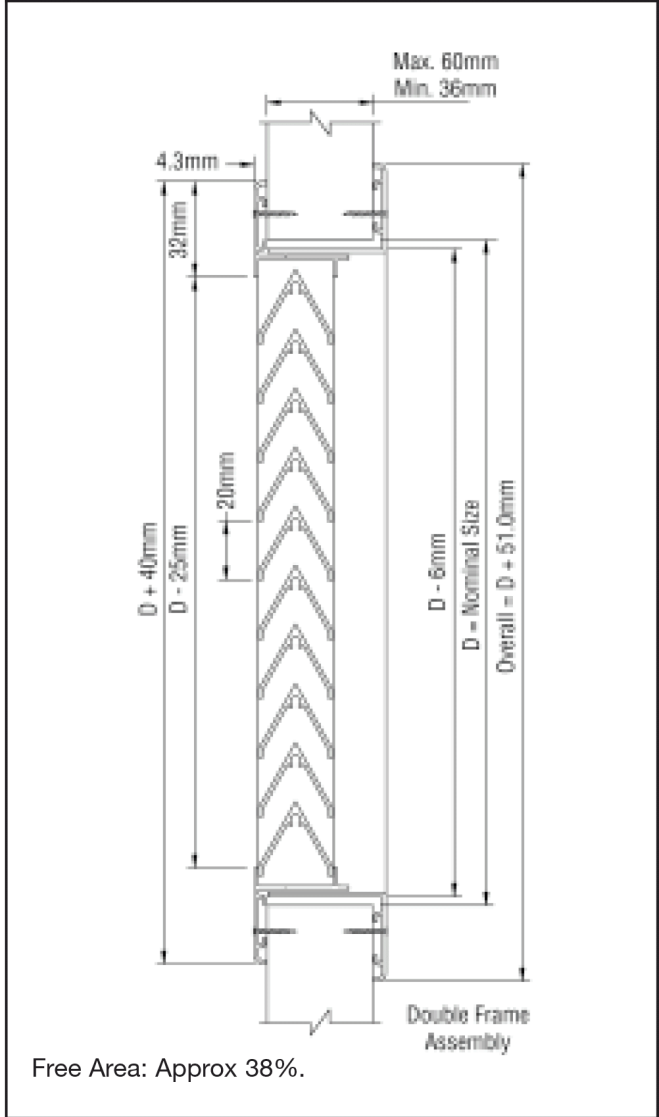

Linear Bar Grilles - Type LG

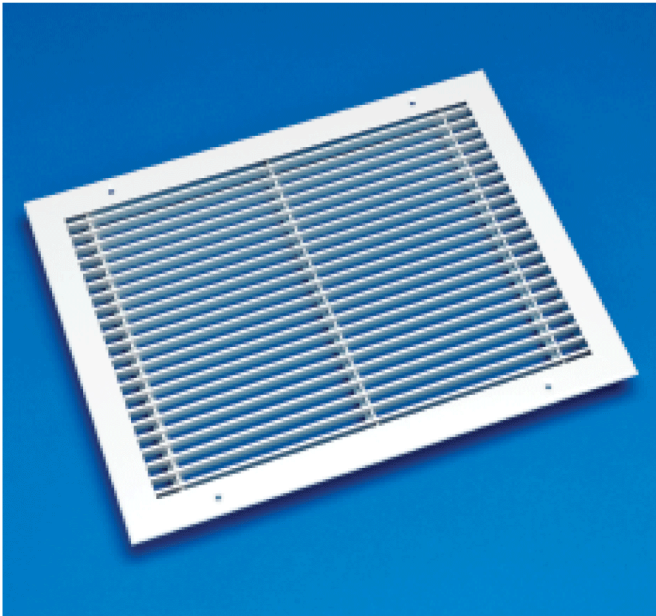

Linear bar grilles have a single row of horizontal blades. They are suitable for cill, ceiling or sidewall installation for supply or extract applications. Models are available with straight or angled blades. Optional blade pitches and styles together with alternative frames are available on request - speak to your local branch for details.

Plenum Boxes - Type PB

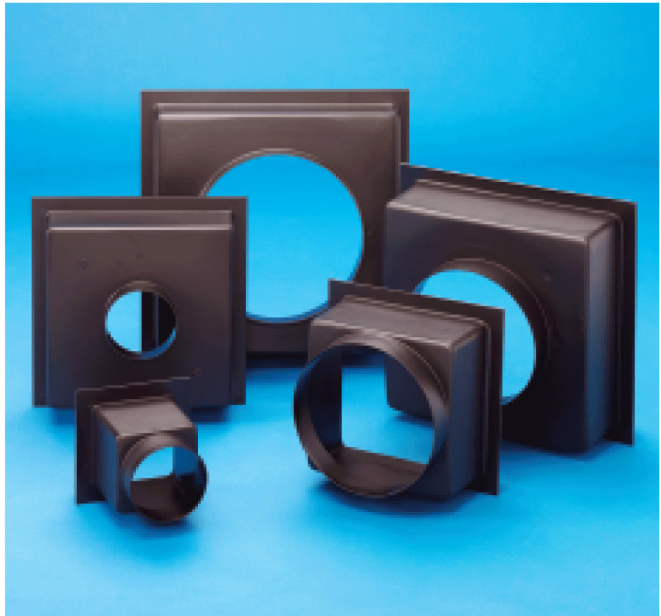

Our range of polymer plenum boxes offer a highly cost effective and lightweight method of ductwork connection to our grille range. The black finish improves installation aesthetics and the non-corrosive easy clean polymer construction helps reduce duct-borne bacteria. **N.B.** Galvanised steel plenum boxes are also available.

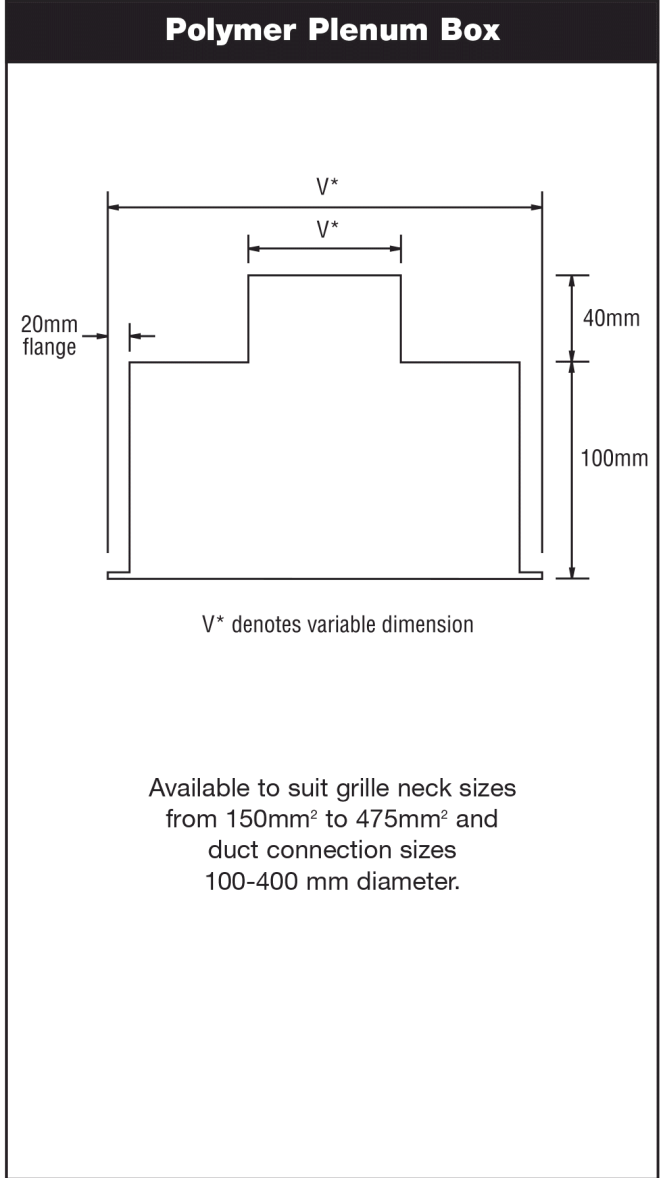
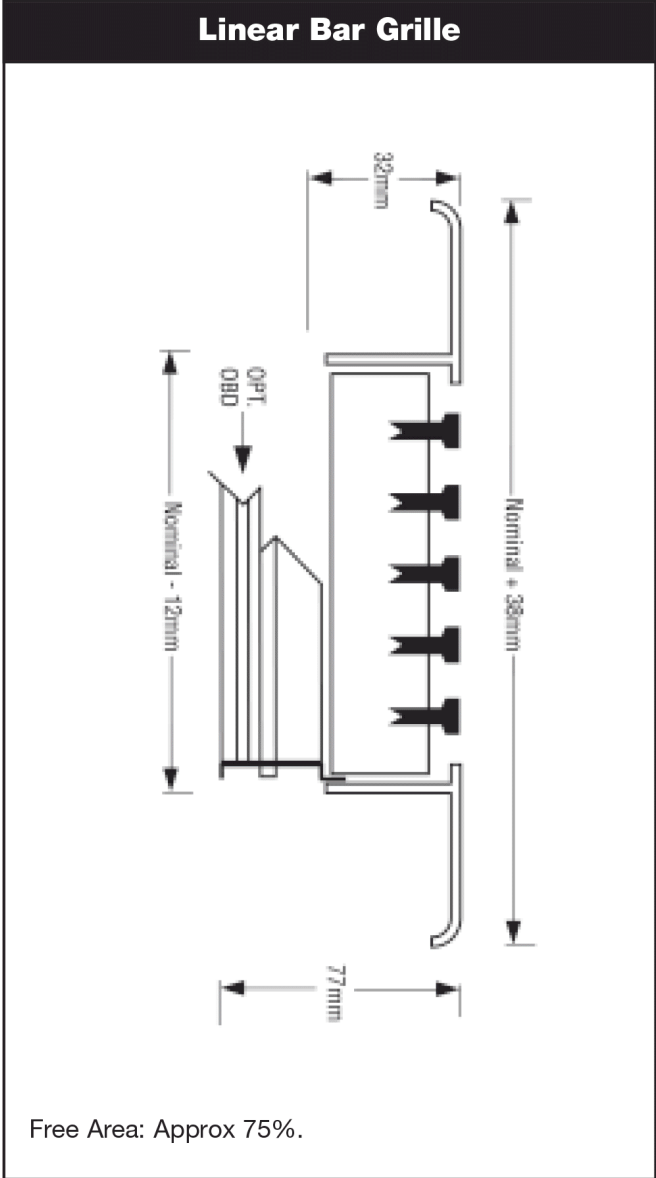

Ceiling Diffusers - Type CD

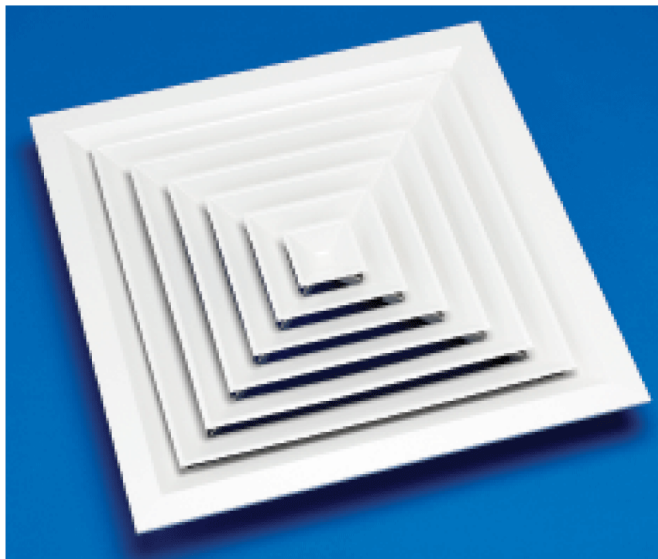

square and rectangular multicone diffusers have been designed to meet a wide range of modern applications and include sizes for ceiling tile replacement. They are supplied as standard with a spring loaded removable centre core for ease of cleaning and adjustment. All diffusers are supplied with a safety cord between the diffuser core and frame.

Size Range

From 150 x 150mm to 600 x 600mm nominal neck size. For 600 x 600 T bar ceilings please specify 450mm square neck *with* 595 x 595 dimensions across face of diffuser.

Fixing

Screw or rivet fixing through the diffuser neck into the duct or plenum box/pan adaptor.

Packaging

Each diffuser is supplied wrapped in polythene with oversized plastic corner pieces to protect diffuser faces and corners. Each unit is marked with the product reference and size for ease of identification.

Construction

diffusers are manufactured from high quality materials with a cleated and welded construction providing excellent mechanical strength and high quality mitred joints.

diffusers are supplied as standard with a polyester powder coated white finish RAL9010.

Options

Paint Finish: Polyester powder coat to BS or RAL colours.

Special Sizes: Available to order.

Dampers: All Diffusers can be supplied complete with an opposed blade damper.

Plenum Boxes: Available in plastic & steel.

Ordering Procedure

Please always order by neck size NOT by opening size in ceiling.

Eg: 450 x 450 4 way blow diffuser with damper: Model CD4/D 450 x 450.

N.B. For a diffuser to fit into a standard 600 x 600 T bar ceiling system specify an overall size of 595 x 595 across face (450 x 450 neck).

Other ceiling style fixings available to order.

Ceiling Diffusers - Type CD

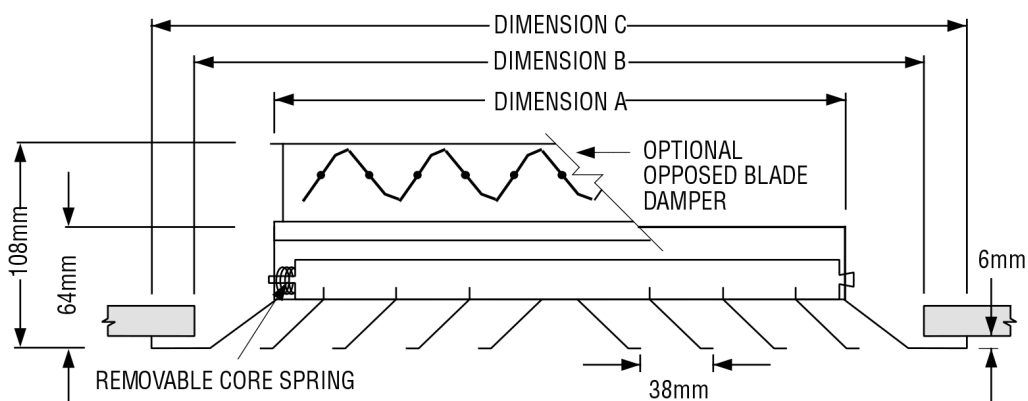

Dimensions for standard sizes

Nominal Unit Size	Actual Neck Dimension 'A'	Minimum Opening Dimension 'B'	Overall Flanges Dimension 'C'
150 x 150	146 x 146	228 x 288	290 x 290
225 x 225	223 x 223	305 x 305	367 x 367
300 x 300	299 x 299	381 x 381	443 x 443
375 x 375	375 x 375	457 x 457	519 x 519
450 x 450*	451 x 451	533 x 533	595 x 595

* 595sq o/all tile replacement diffuser.

Dimensions are in mm.

Other sizes available to order.

Product selection data available on request.

Twisted Swirl Diffusers - Type TCD

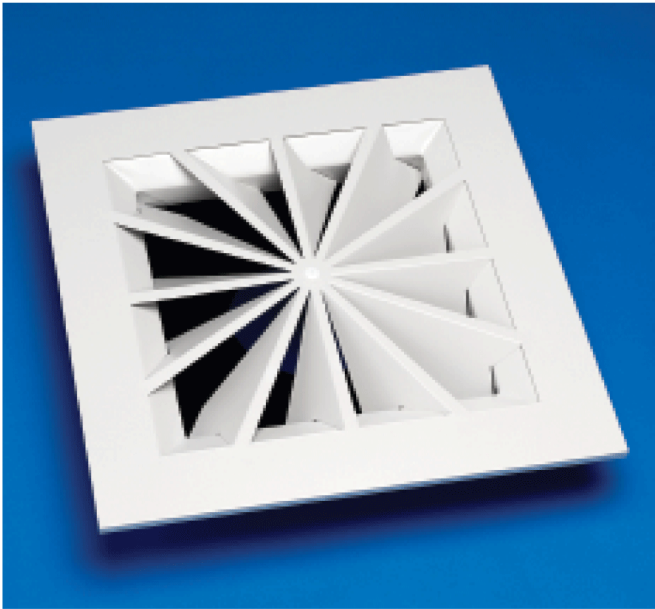

Our attractive 'Twister' Swirl Diffuser is a high performance ceiling diffuser which is ideal for VAV applications. The radial vane design produces an unmatched high induction swirl pattern designed to optimize occupant comfort by minimising stratification.

Architectural Diffuser - Type ACD

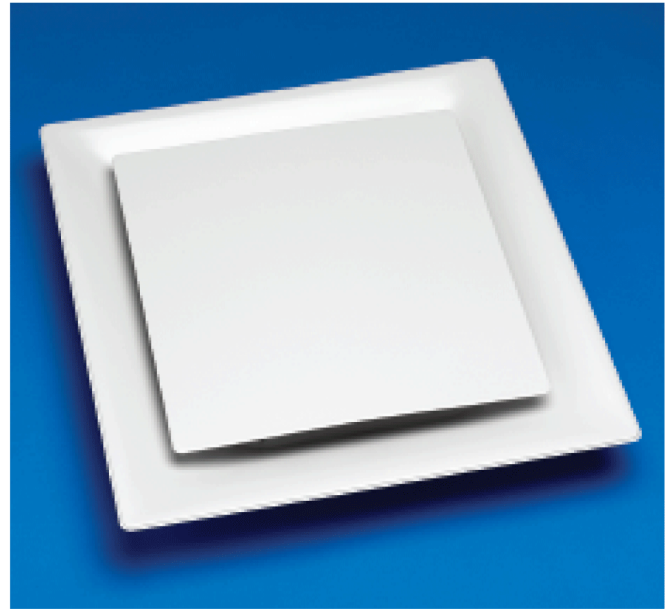

Our Architectural Ceiling Diffuser has been designed to provide an unobtrusive appearance and a 360 degree diffusion pattern at minimum NC levels. The stamped one piece outer core eliminates mitred corners and die formed curves provide consistent quality performance.

Twisted Swirl Diffuser

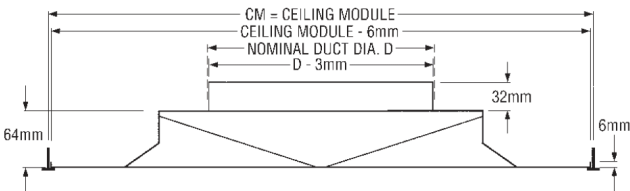
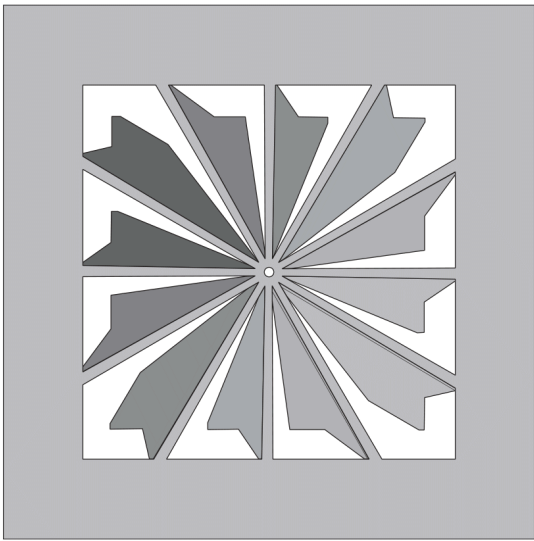

Available 594 x 594mm to suit 600mm sq ceiling grid with neck sizes available to suit 100, 150, 250, 300 and 350mm diameter duct.

Architectural Ceiling Diffuser

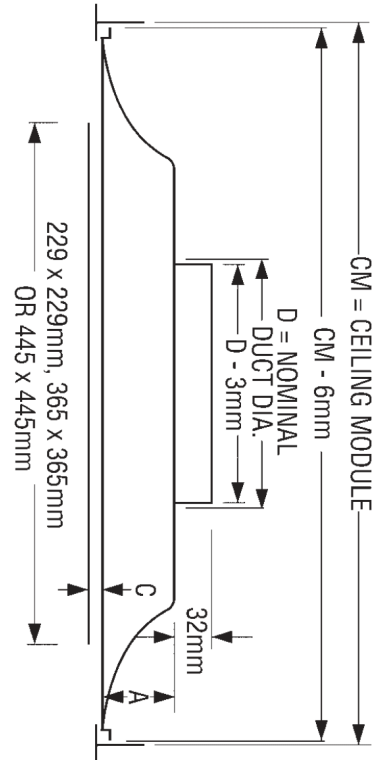

DUCT SIZE			
CM	D	A	C
600 x 600	152, 203	59	10
	254, 305		
	356, 381		
500 x 500	152, 203, 254	57	11
	300 x 300	127, 152, 178, 203	25

Product selection data available on request.

Circular Ceiling Diffuser - Type CCD



Circular Ceiling Diffusers are specifically designed to ensure even distribution of air and quietness in operation. The inner core fixes easily and quickly to the outer support cone and all edges are beaded to give greater rigidity and neater appearance. Adjustment of the diffuser is achieved via the central threaded cone.

Perforated Face Grilles - Type PFD

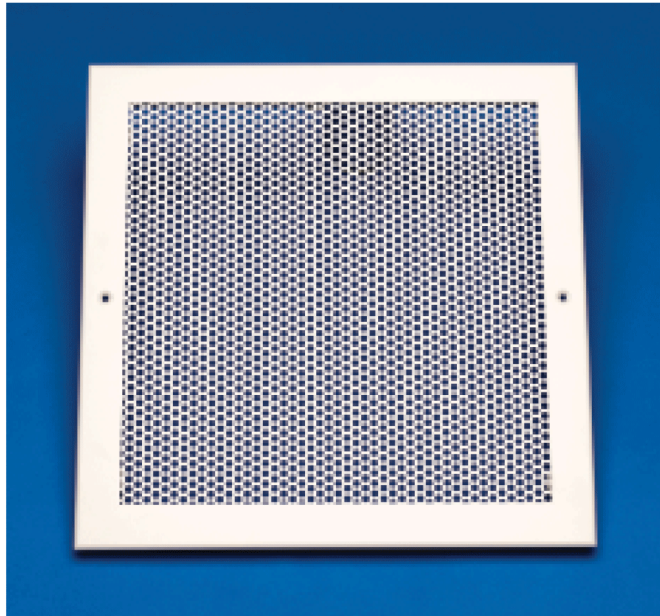

perforated grilles are medium capacity return or exhaust outlets. The perforated core has 5mm dia staggered holes on 6mm centres and provides 50% free area. Their design is clean and unobtrusive providing an uncluttered appearance favoured by many architects.

Circular Ceiling Diffuser

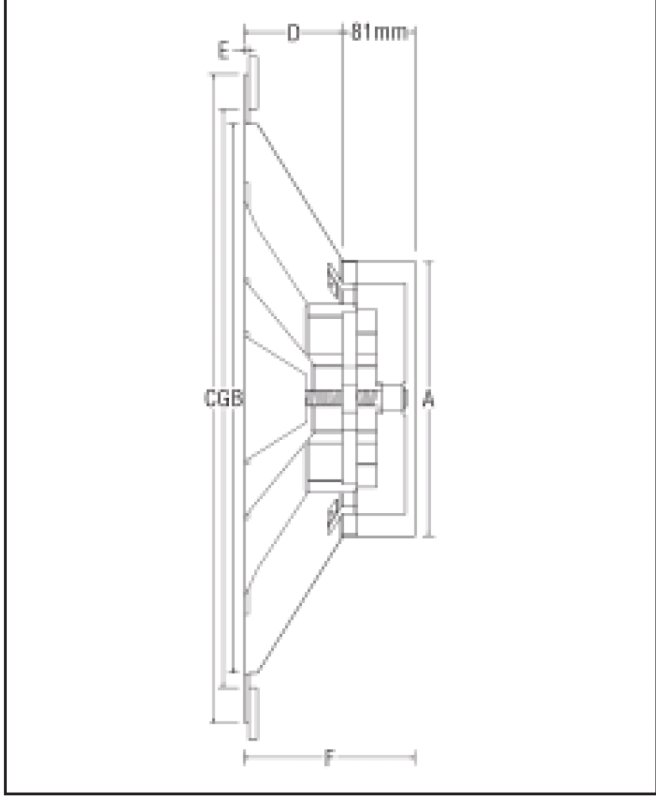

Size	A	B	C	D	E	F	G
6"	152	305	340	51	5	110	320
8"	203	407	457	64	6	127	430
10"	254	508	569	86	5	146	530
12"	308	610	680	95	6	155	640
15"	381	762	851	121	6	172	800
18"	457	914	1041	146	-	248	950
21"	634	1080	1148	178	-	280	1100

Perforated Face Grille

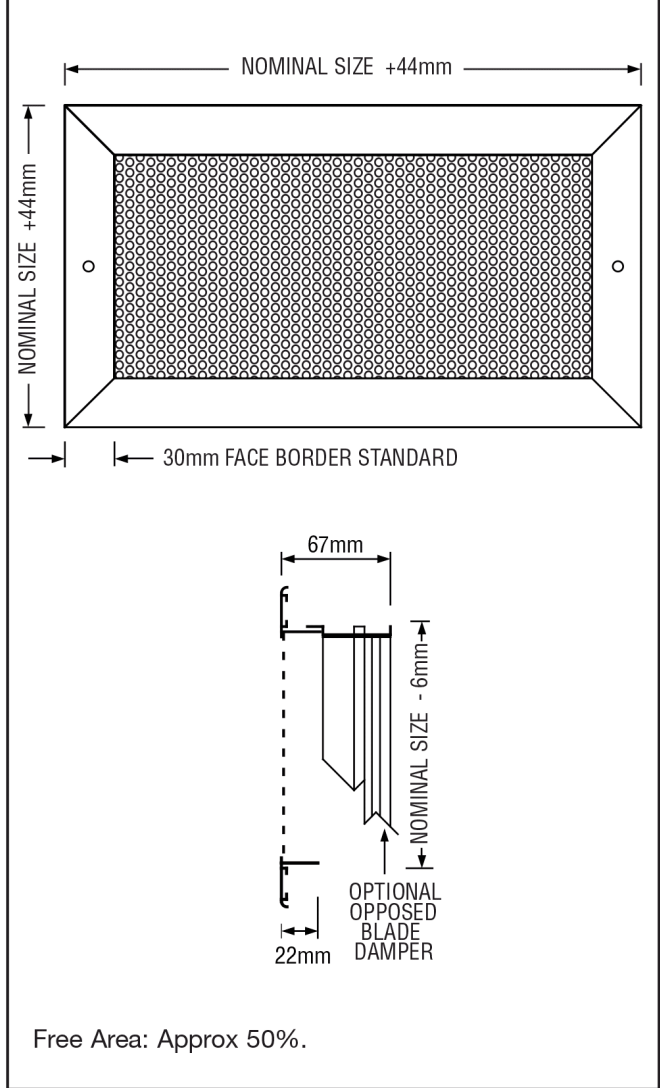

Product selection data available on request.

38mm Pitch Weather Louvre - Type WG38



Our external weather louvre is supplied complete with bird mesh screen as standard. The 38mm pitch blade is ideal for most applications and provides a balanced appearance whilst offering excellent resistance to the penetration of rain. Louvres are supplied in mill finish as standard with special paint finishes available to order.

Available up to 1200mm x 1200mm.

50mm Pitch Weather Louvre - Type WG50



Our 50mm pitch weather louvre is available in sizes up to 2000 x 2000 in single sections and like the 38mm pitch louvre, comes complete with bird mesh screen and is mill finish as standard with special paint finishes available to order.

Sizes over 2000mm sq are available as multiple assemblies.

38mm Pitch Weather Louvre

STANDARD FLANGED FRAME

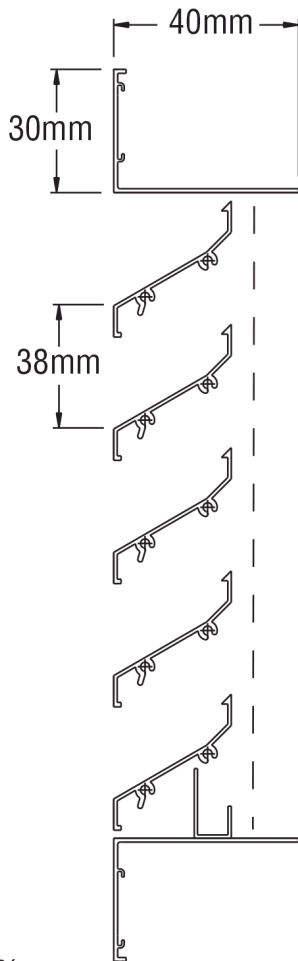

50mm Pitch Weather Louvre

STANDARD FLANGED FRAME

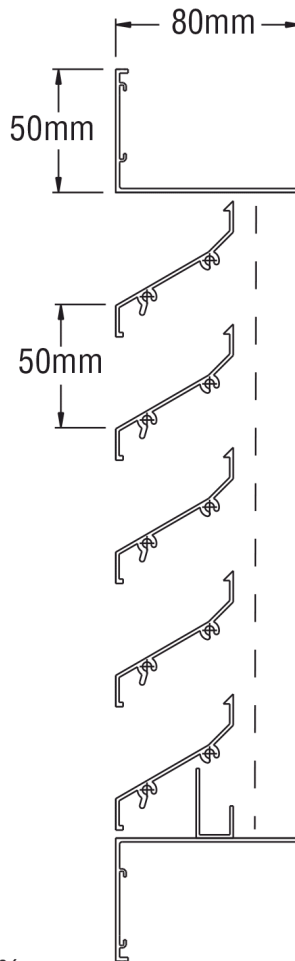

Note: 75 and 100mm pitch louvres also available.

Product selection data available on request.

Air Exhaust Valve Type KSO



Keeping noise and cost levels down to a minimum are probably the two biggest problems an engineer designing a ventilation system has to face today. The patented Model KSO Exhaust Valve has been developed with these criteria in mind and has a very low noise level even when the pressure drop across it is large. This characteristic allows relatively high air velocities to be used, permitting the selection of the most economical size of ductwork and exhaust valves.

Adjustment of the airflow is simple, the inner cone being rotated to the required setting and locked in position with a single nut. Each air valve is supplied complete with a mounting ring from which it can be simply removed for cleaning without affecting the setting of the valve.

Construction

The outer body and inner cone are constructed from sheet steel, stove enamelled white. The outer body is fitted with a gasket to form an airtight seal with the mounting ring.

Sizes

The Model KSO is manufactured in five sizes, 100, 125, 150, 160, 200mm (external diameter of mounting ring).

KSO Air Exhaust Valve

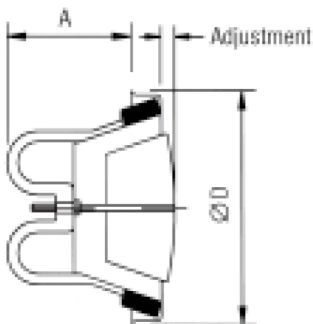

Product	ø D (mm)	A (mm)	Weight (g)
KSO 100	134	74	280
KSO 125	160	85	360
KSO 150	191	89	470
KSO 160	191	89	470
KSO 200	241	107	720

Air Exhaust Valve Type KK



The Model KK Exhaust Valve is suitable for use with all types of ventilating systems and offers an alternative low cost valve where noise level, although important, is not critical. Complete with mounting ring.

Adjustment of the airflow is simple, the inner cone being rotated to the required setting and locked in position with a single nut. Each air valve is supplied complete with a mounting ring from which it can be simply removed for cleaning without affecting the setting of the valve.

Construction

The outer body and inner core are constructed from sheet steel, stove enamelled white. The outer body is fitted with a gasket to form an airtight seal with the mounting ring.

Sizes

The Model KK is manufactured in six sizes, 80, 100, 125, 150, 160, 200mm (external diameter of mounting ring).

KK Air Exhaust Valve

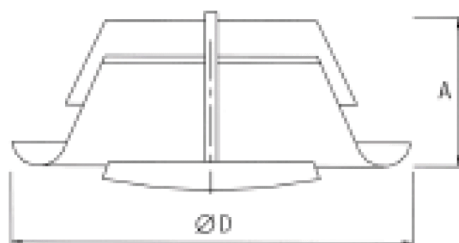

Product	ø D (mm)	A (mm)	Weight (g)
KSO 80	115	42	150
KSO 100	138	40	160
KSO 125	164	46	230
KSO 150	202	50	330
KSO 160	211	55	370
KSO 200	248	63	510

Plastic supply and extract valves are also available.

Air Supply Valve Type KE



The Model KE Air Supply Valve is designed to supply air at relatively high velocities whilst maintaining low noise characteristics.

Adjustment of the airflow is simple, the inner cone being rotated to the required setting and locked in position with a single nut. Each air valve is supplied complete with a mounting ring from which it can be simply removed for cleaning without affecting the setting of the valve.

Construction

The outer body and inner cone are constructed from sheet steel, stove enamelled white. The outer body is fitted with a gasket to form an airtight seal with the mounting ring.

Air Exhaust Fire Damper Valve Type KSO-P



Model KSO-P is a combination fire damper and air valve for exhaust air ventilation systems.

The damper blade will close when the temperature in the vicinity of the valve reaches the fusible link rating - standard temperature 70°C. (Alternative release temperatures of 50°C and 100°C available to special order).

Adjustment of the airflow is simple, the inner cone being rotated to the required setting and locked in position with a single nut. Each air valve is supplied complete with a mounting ring from which it can be simply removed for cleaning without affecting the setting of the valve.



Sizes

The Model KSO-P is manufactured in five sizes, 100, 125, 150, 160, and 200mm (external diameter of mounting ring).

KE Air Supply Valve

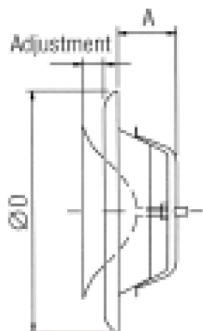

KSO-P Air Exhaust Fire Damper Valve

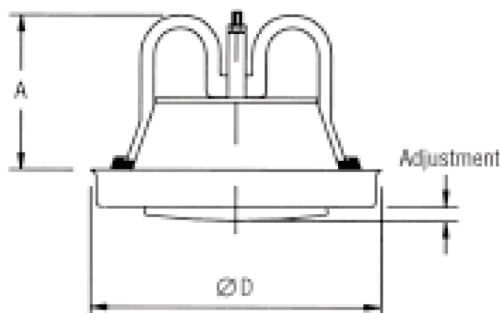

Product	ø D (mm)	A (mm)	Weight (g)
KE 80	115	41	140
KE 100	137	47	190
KE 125	164	49	310
KE 150	202	51	350
KE 160	212	60	500
KE 200	248	75	730

Product	ø D (mm)	A (mm)	Weight (g)
KSO-P 100	134	74	305
KSO-P 125	160	85	390
KSO-P 150	191	89	575
KSO-P 160	191	89	575
KSO-P 200	241	107	765

Plastic supply and extract valves are also available.

Spiral Duct Grilles

Type RGS

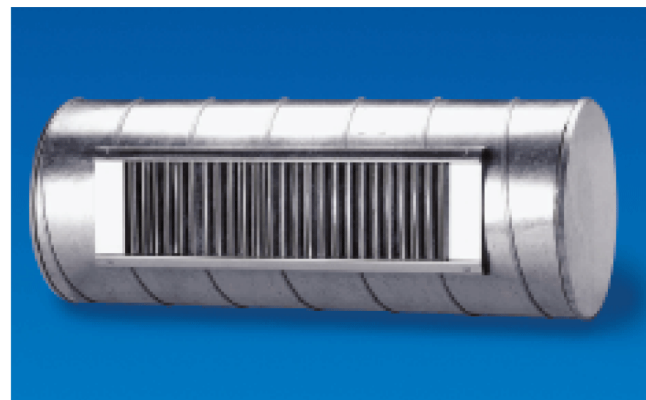

Description

spiral duct grilles have been designed for fitting directly to circular ducts without the need for a special take-off.

For supply grilles the angled hit and miss sliding damper acts as an air turn as well as a damper.

Construction

RGS grilles are manufactured from hot galvanized steel plate and are assembled without welding. This means that the grille can be used without further surface treatment and the exterior of the grille matches the surface of the spiral duct onto which it is mounted.

Model References

RGS-1 Double deflection grille without damper
 RGS-7 Double deflection grille with angled hit and miss damper

Fixing

By self tapping screws (provided) through pre-drilled holes in grille frame.

Ordering Procedure

A grille designed for supply air applications must have an angled hit and miss damper (code RGS-7). Please give required length first followed by height and ensure that an appropriate height has been selected for the duct diameter (see table)

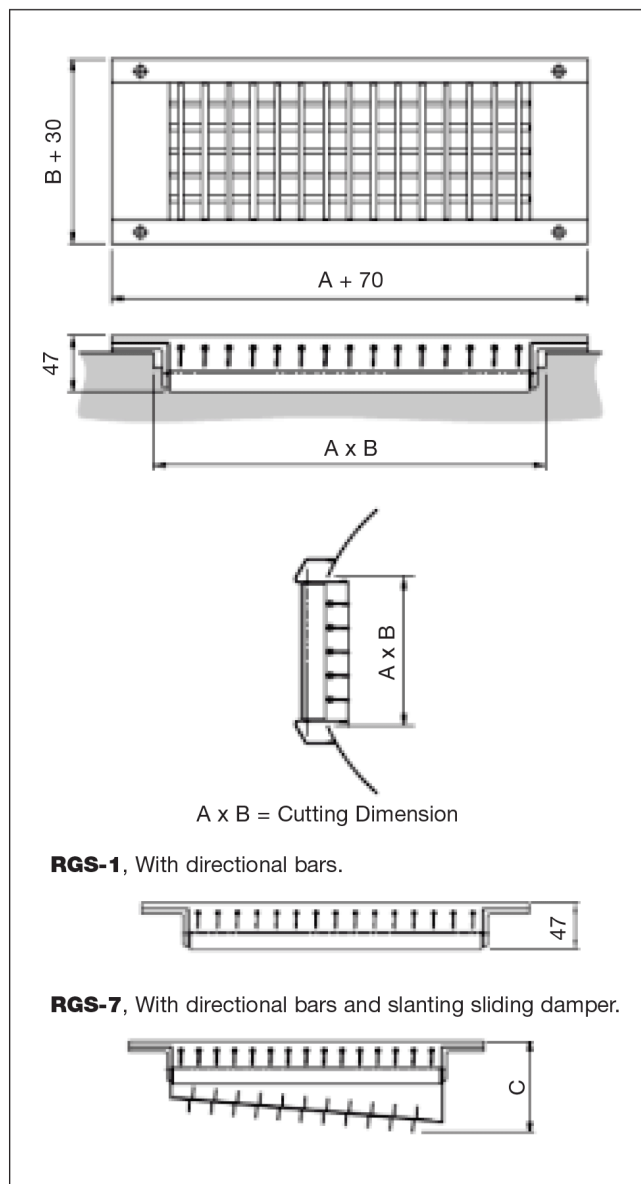

A x B	Minimum Duct Diameter	Free are (M ³)	Dimension "C" (RGS-7)
325 x 75	160	0.017	106
325 x 150	315	0.034	106
325 x 225	500	0.056	106
525 x 75	160	0.028	126
525 x 150	315	0.056	126
525 x 225	500	0.093	126
825 x 75	160	0.045	151
825 x 150	315	0.093	151
825 x 225	500	0.18	151
1025 x 75	160	0.056	186
1025 x 150	315	0.112	186
1025 x 225	500	0.224	186