



AVAILABLE NOW FROM
i-sells.co.uk



Showroom:

15 St John's Parade
Sidcup High Street
DA14 6ES

EMAIL: sales@i-sells.co.uk
SALES: 020 8463 9696
WEB: www.i-sells.co.uk

Lo-Carbon SELV Temptra

THROUGH THE WALL
HEAT RECOVERY FAN

Installation and Wiring Instructions



Stock Ref. N°

- 444368 Pullcord. (P)
- 403833 Pullcord Long cell (LP)
- 444369 Timer. (T)
- 403835 Timer Long cell (LT)
- 444370 Humidistat -Timer
Pullcord. (HTP)
- 403837 Humidistat -Timer
Pullcord Long cell. (LHTP)

220-240V~50Hz SELV

Vent-Axia®

PLEASE READ INSTRUCTIONS IN CONJUNCTION WITH ILLUSTRATIONS.
PLEASE SAVE THESE INSTRUCTIONS.

IPX4



Installation and Wiring Instructions for the Temptra SELV Range of Heat Recovery Fans.



**IMPORTANT:
READ THESE INSTRUCTIONS
BEFORE COMMENCING THE
INSTALLATION**

DO NOT install this product in areas where the following may be present or occur:

- Excessive oil or a grease laden atmosphere.
- Corrosive or flammable gases, liquids or vapours.
- Ambient temperatures higher than 40°C or less than – 5°C.
- Possible obstructions which would hinder the access or removal of the Fan.

SAFETY AND GUIDANCE NOTES

- A. All wiring to be in accordance with the current I.E.E. Regulations, or the appropriate standards of your country and **MUST** be installed by a suitably qualified person.
- B. The Fan should be provided with a local isolator switch capable of disconnecting all poles, having a contact separation of at least 3mm.
- C. Ensure that the mains supply (Voltage, Frequency, and Phase) complies with the rating label.
- D. The electrical supply to this fan is 24v DC SELV from the transformer/controller. This means the fan may be installed within reach of a person using a fixed bath or shower, i.e. in a nearby wall. However, the fan must not be placed where it could be submerged in water or regularly exposed to direct water spray, e.g. from a shower head whether permanently fixed or movable.
- E. **ONLY CONNECT TOGETHER THE PRODUCTS FROM THE Lo-CARBON TEMPTRA SELV RANGE SINCE THE FANS ARE SPECIALLY DESIGNED TO WORK ON 24v DC AND ARE NOT COMPATIBLE WITH OTHER VENT-AXIA CONTROLLERS. DO NOT CONNECT MORE THAN ONE FAN TO THE CONTROLLER.**
- F. The controller must not be installed in a shower cubicle or enclosure. It must be away from direct sources of water spray and out of reach of a person using a fixed bath or shower. Site away from direct sources of heat.
- G. The controller needs free air circulation and must not be covered with any insulating material such as might be in a ceiling or roof void.
- H. The Fan should only be used in conjunction with the appropriate Vent-Axia products.
- I. The fan should only be used in conjunction with fixed wiring.
- J. When the Fan is used to remove air from a room containing a fuel-burning appliance, precautions must be taken to avoid back-flow of gases into the room from the open flue of gas or other appliance. Ensure that the air replacement is adequate for both the fan and the fuel-burning appliance.
- K. The Fan should not be used where it is liable to be subject to direct water spray for prolonged periods of time.
- L. The horizontal duct should be arranged to slope slightly downwards away from the Fan.
- M. This appliance is not intended for use by young children or infirm persons without supervision.
- N. Young children should be supervised to ensure that they do not play with the appliance.

Disposal

This product should not be disposed of with household waste.
Please recycle where facilities exist.
Check with your local authority for recycling advice.



DESCRIPTION

Through the wall Mounted Heat Recovery Fan

The Vent-Axia Lo-Carbon Tempra SELV is suitable for refurbishment or new build, kitchen, bathroom, toilet or utility applications. The unit meets the performance requirements for intermittent extract fans under the Building Regulations Part F 2010 (table 5.1a) and also for continuous running products

Tempra SELV is available in 6 models

444368 – Tempra SELV P

403833 - Tempra SELV LP Constant trickle speed with pull cord or switch live to boost airflow.

444369 – Tempra SELV T

403835 - Tempra SELV LT Constant trickle speed with switch live to boost airflow with adjustable 5-50 min overrun timer and optional 3 minute delay on timer.

444370 – Tempra SELV HTP

403837 - Tempra SELV LHTP Constant trickle speed with pull cord or switch live to boost airflow with adjustable 5-50 min overrun timer and optional 3 minute delay on timer or internal humidistat adjustable 60- 90% RH.

SELV Controller

The controller can be installed surface or recess mounted using the supplied surface mounting box or a standard mounting box. Please note that the fixing screws may have to be replaced with screws suitable for the type of mounting box used.

A. INSTALLATION

WALL MOUNTING

Models **P, T & HTP** are designed for use in a wall with a maximum thickness of 318mm fitted with a 110mm Soil pipe or Wall Sleeve (Stock Ref No 445529).

Models **LP, LT & LHTP** are designed for use in a wall with a maximum thickness of 460mm fitted with a 110mm Soil pipe.

1) Using the template provided mark the 4 wall fixing positions, the hole for the wall pipe and mains cable entry point.

2) Cut a hole through the wall and insert the soil pipe or wall sleeve.

Slope the sleeve slightly downwards away from the fan and cement both ends into position flush with the wall Fig 1

3) Undo 2 fixing screws and lift off Cover Plate Fig 2 & 3.

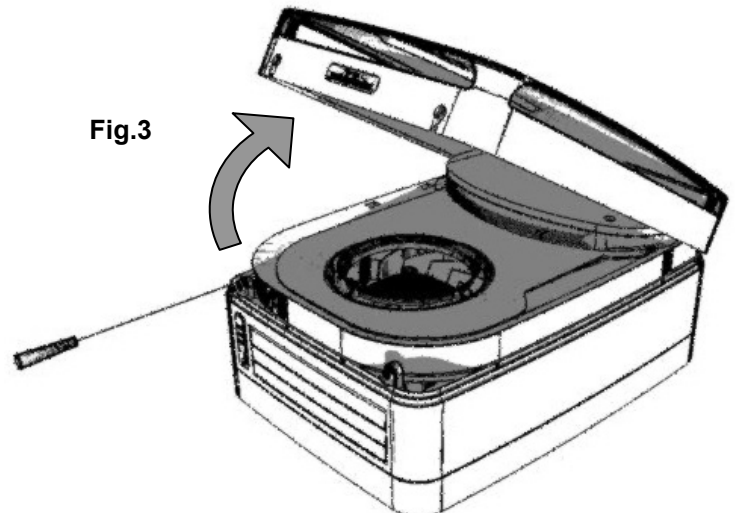
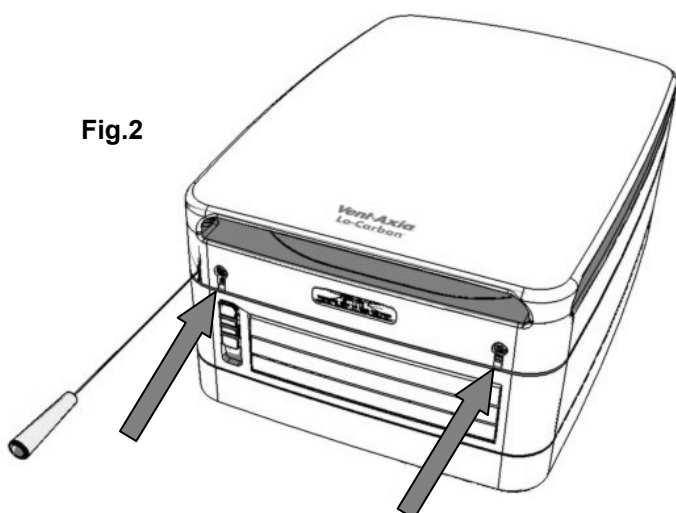
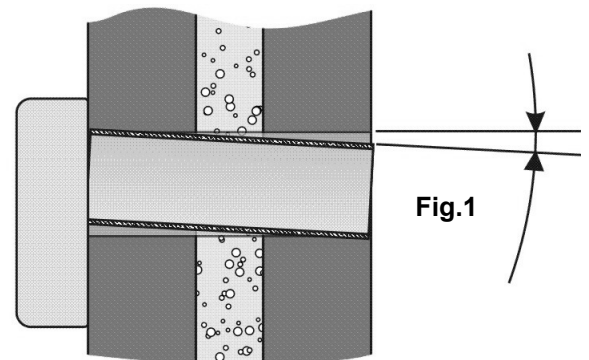

4) Remove 2 screws and detach Electrical Cover fig 4.

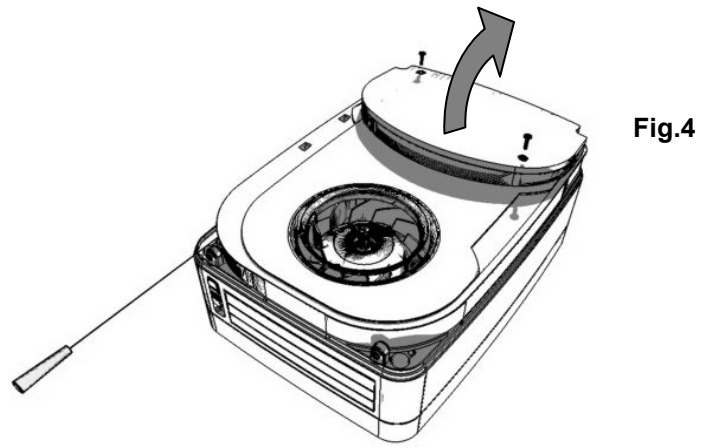

5) Lift where indicated to engage hinges Fig 5 and open Door Fig 6.

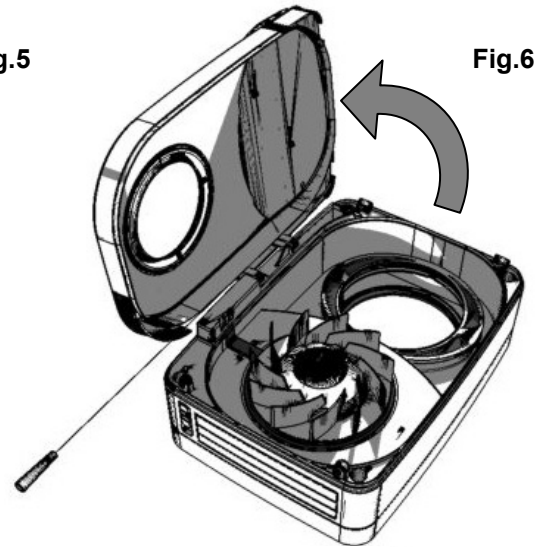
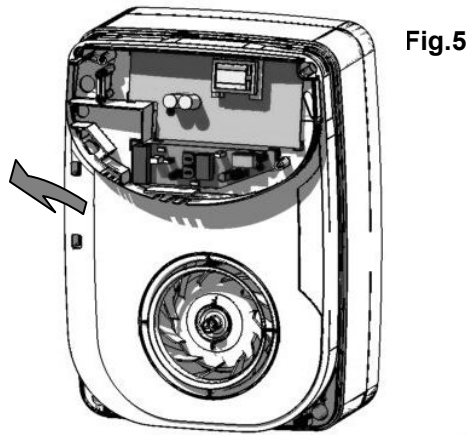

6) Feed flexible LV cable from PSU through one of the rear entry points or the side entry point as required. And then the door Fig 7 & 8.

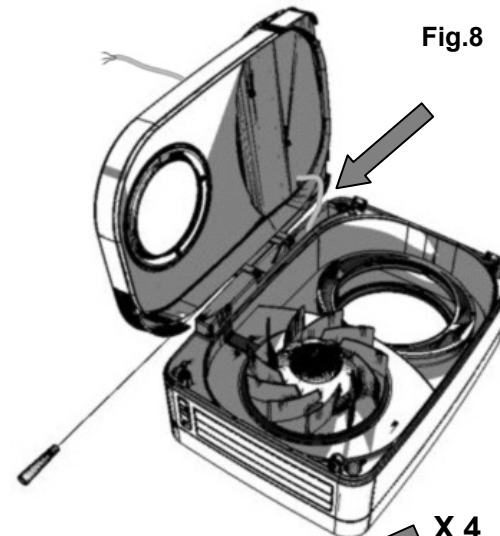
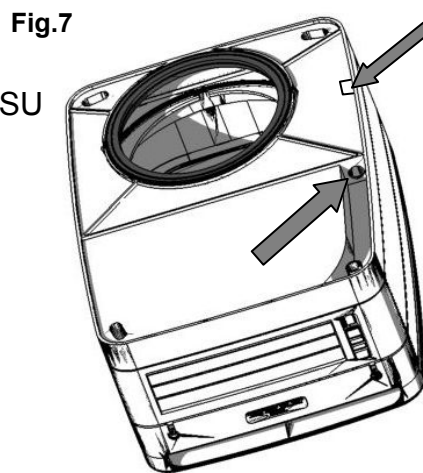

7) Fit Chassis to wall with 4 fixing screws carefully aligning the hole in the back of the Tempra with the Wall Pipe Fig 9.

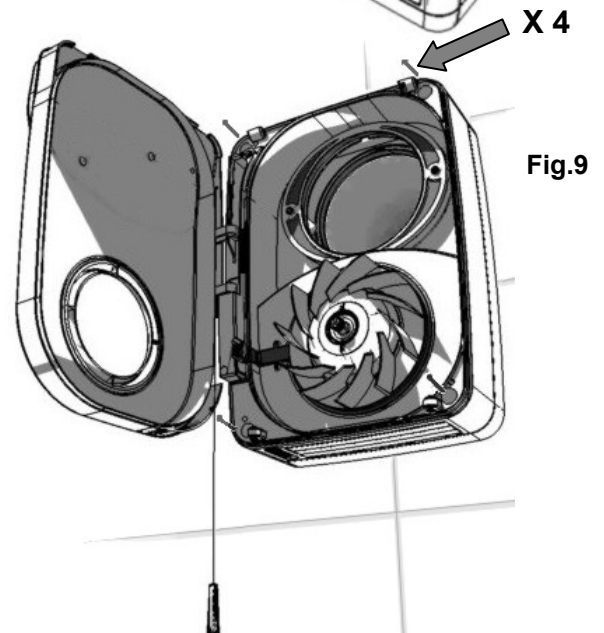

8) Remove screws and Heat Exchanger Retaining Clamp kit Fig 10. (Discard polybag)

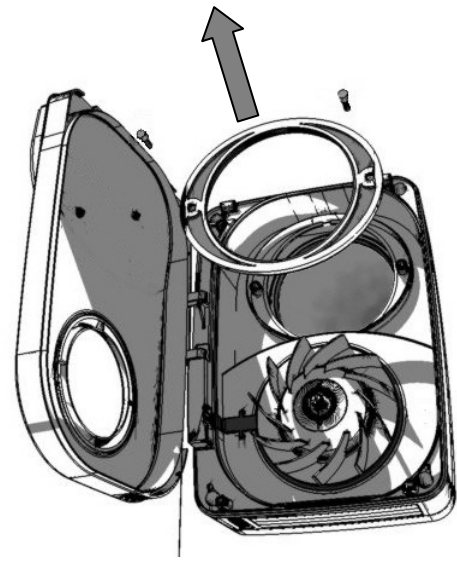

Fig.10

9) Insert Heat Exchanger through Chassis and into Wall pipe Fig 11.

Note: Line up key on top of Heat Exchanger with slot in Chassis

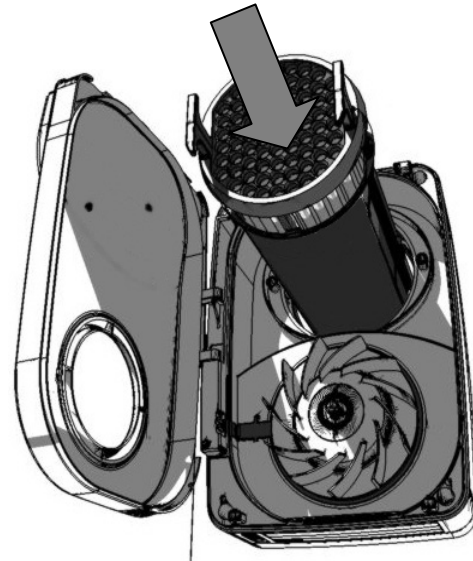

Fig.11

10) Fit Heat Exchanger Retaining Clamp with the screws provided Fig 12.

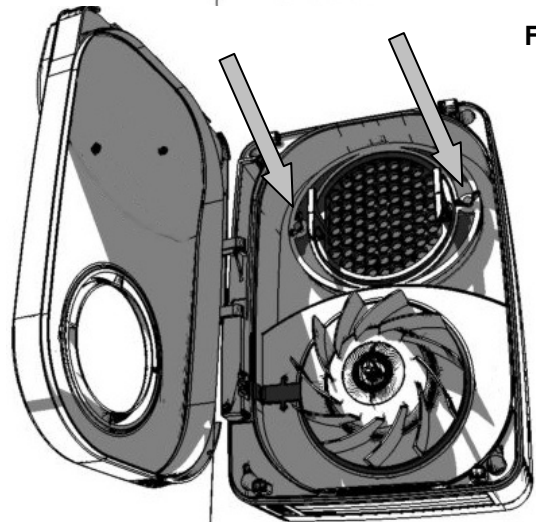

Fig.12

11) Close Door and connect 24V Supply as described in section B – Wiring, Adjust any settings as required see section C – Setup. Fig 13

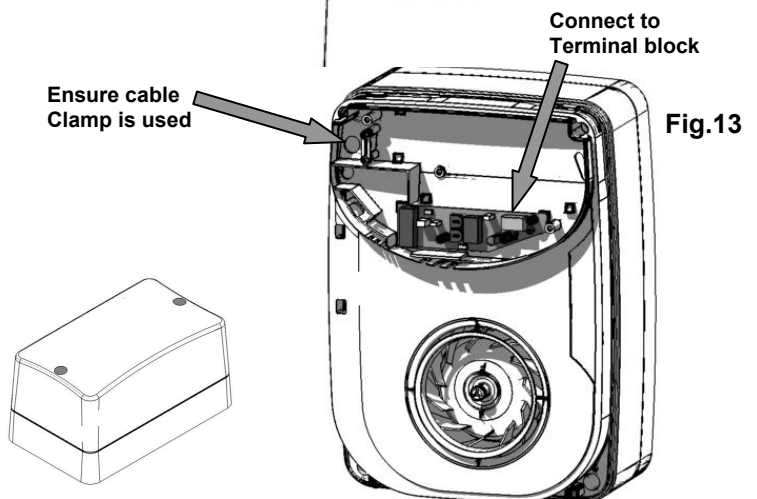

Fig.13

12) Re fit Electrical Cover with 2 screws indicated In Fig 14.

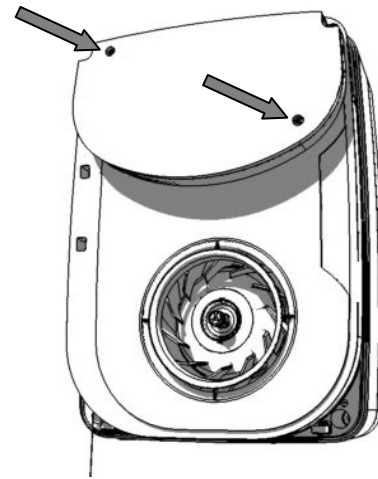

Fig.14

13) Re fit Cover Plate and tighten 2 screws Fig 15 &16. Ensure Pull cord is engaged in Lower Slot

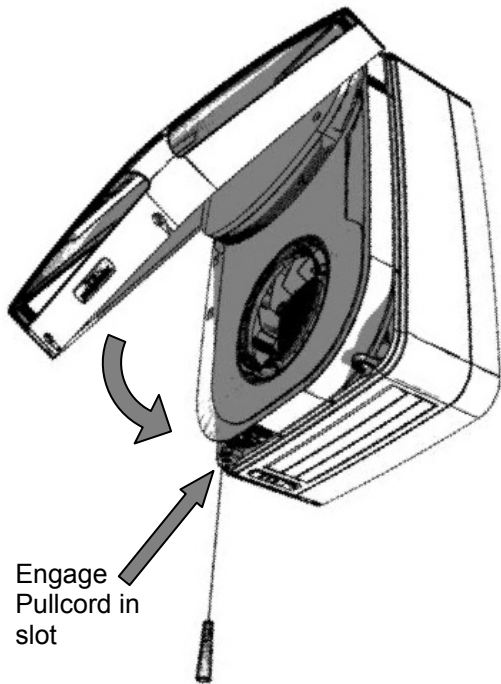

Fig.15

Engage Pullcord in slot



Fig.16

Ensure this vent is **open** when installed to activate the heat recovery function

14) The Tempra unit is also fitted with a “manual summer setting” which allows the unit to be set to extract only, helping to prevent a dwelling becoming too warm in hot summer conditions. When first installed this shutter/vent should be **open**. Fig.16

To activate the summer setting it should be shut.

15) Make good on outside wall with the wall Cover bezel provided, ensure the arrow on the bezel is at the top. Fix/seal to the wall with a suitable sealant.

Apply sealant in outer groove on rear of bezel.

Important:- Please ensure that you apply sufficient sealant to hold the bezel to the wall. (If the wall surface is not suitable for using sealant 2 screws can be located through the 2 bosses provided).

Note:- Do not seal the bezel to the heat exchanger, this needs to be removed for cleaning at regular intervals.

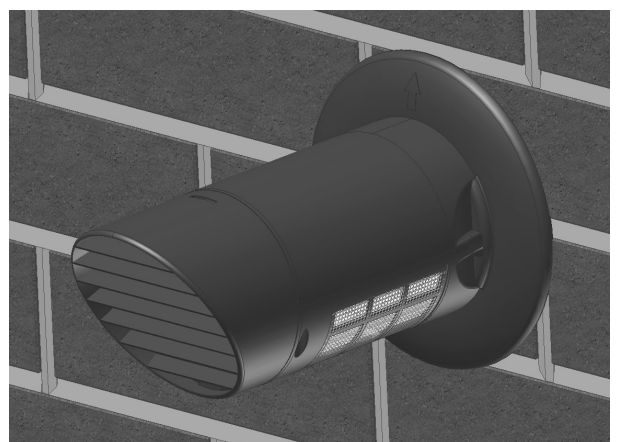
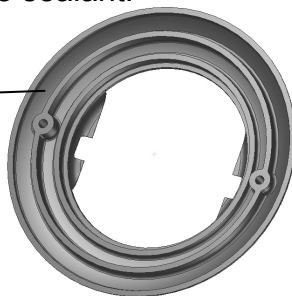

Fig.17

B. WIRING.



WARNING: THE FAN AND ANCILLARY CONTROL EQUIPMENT MUST BE ISOLATED FROM THE POWER SUPPLY DURING THE INSTALLATION / OR MAINTENANCE.

IMPORTANT

- The fan should only be used in conjunction with fixed wiring.
- The cross - sectional area of supply cord used should range from 1 -1.5mm².
- Cable entry can only be made from the rear of the fan.
- Allow sufficient 24V flexible cable when connecting fan, to ensure hinged door opens freely.
- The Controller is suitable for connection to 220-240V 50Hz supply and 24V SELV to the fan.
- The fan is a class II double insulated product and **MUST NOT** be earthed.

1. Select and follow the appropriate wiring diagram. (Fig. 18 or 19)
2. Check all connections have been made correctly and ensure all terminal connections and cable clamps are securely fastened.

Fig 18

Continuous trickle (6l/s or 9l/s) with pullcord boost facility SELV P,LP and SELV HTP, LHTP

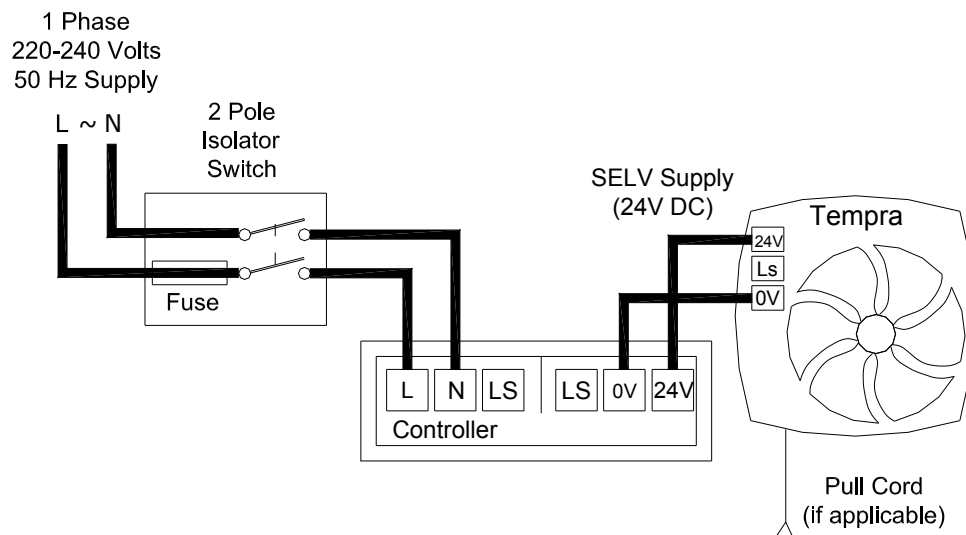
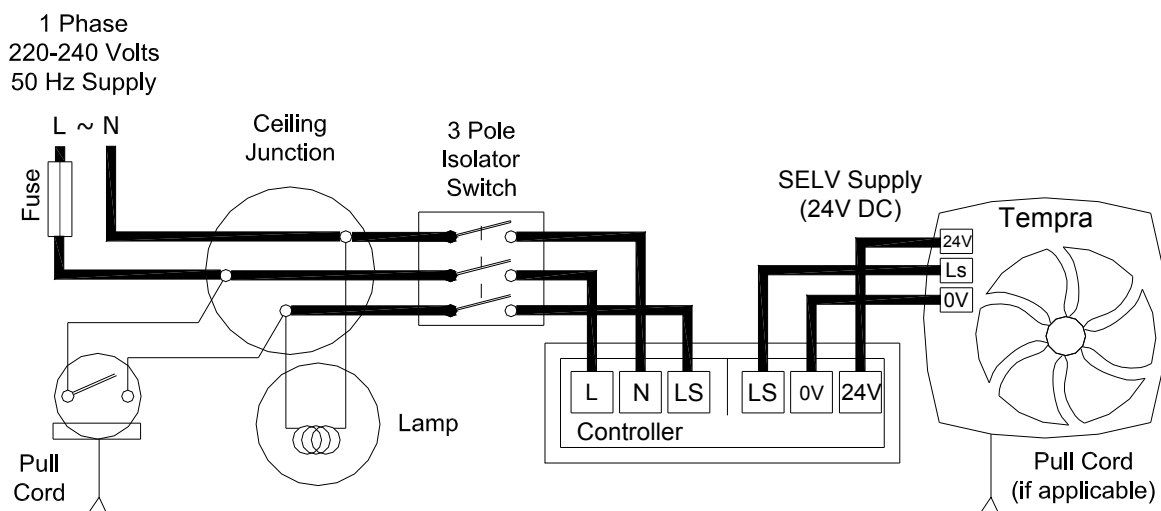

Fig 19

Continuous trickle (6l/s or 9l/s) with switch live boost facility



C. SETUP



WARNING: THE FAN AND ANCILLARY CONTROL EQUIPMENT MUST BE ISOLATED FROM THE POWER SUPPLY DURING THE INSTALLATION / OR MAINTENANCE.

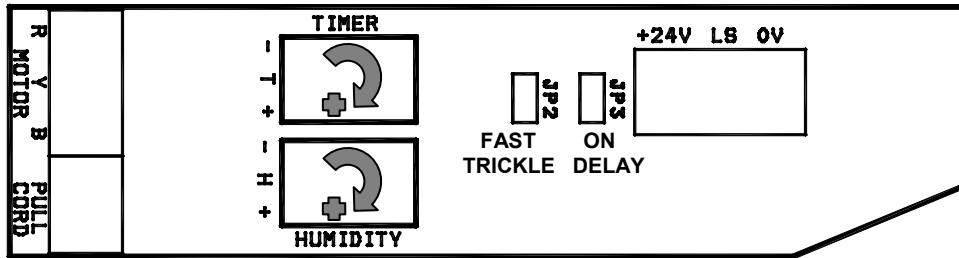

Fig. 20

TRICKLE SPEED SELECTION (6l/s or 9l/s) – (Fig. 20)

In Trickle running mode the fan can extract at either 6l/s (22m³/h) or 9l/s (32m³/h) flow rate. The fan will boost to 15l/s (54m³/h) when the LS / Humidity / Pull cord connection is switched.

- Factory set at **6l/s** (22m³/h).
- Remove jumper connector (**JP2**) if **9l/s** (32m³/h) extract flow rate is required.

PULLCORD OPERATION (P,LP AND HTP,LHTP MODELS)

THE PULLCORD ACTIVATES THE BOOST TO ON OR OFF.

TIMER ADJUSTMENT (T,LT AND HTP,LHTP MODELS) (FIG. 20)

THE TIMER IS ONLY ACTIVATED VIA THE LS CONNECTION.

1. The controller is factory set at 15 minutes approx. The overrun time period can be adjusted from 5-50 minutes by altering the adjuster on the control PCB.
2. To **INCREASE** the operating time, use a small screwdriver to turn the **TIMER** adjuster **CLOCKWISE**.
3. To **REDUCE** the operating time, use a small screwdriver to turn the **TIMER** adjuster **ANTI CLOCKWISE**.
4. In addition a 3 minute delay on timer is included this can be de-activated by removing (**JP3**).

HUMIDITY SET-POINT ADJUSTMENT SVHTP MODEL (FIG. 20)

NOTE:- ON INSTALLATION IT IS POSSIBLE THAT THE HUMIDITY CONTROLLER WILL RUN CONTINUOUSLY UNTIL IT HAS ACCLIMATIZED TO THE ENVIRONMENT.

1. The controller is factory set to switch on at about 70% RH. The humidity set point can be adjusted from 60-90%RH by altering the adjuster on the control PCB.
2. To **LOWER** the set-point use a small screwdriver to turn the **HUMIDITY** adjuster **ANTI-CLOCKWISE**. This makes the controller **MORE** sensitive.
3. To **RAISE** the set-point use a small screwdriver to turn the **HUMIDITY** adjuster **CLOCKWISE**. This makes the controller **LESS** sensitive.

D. MAINTENANCE.



WARNING: THE FAN AND ANCILLARY CONTROL EQUIPMENT MUST BE ISOLATED FROM THE POWER SUPPLY DURING MAINTENANCE.

The fan should be cleaned to ensure there is no build up of dirt or other deposits.

1. Remove 2 screws and lift off
Cover Plate assembly Fig 21 & 22.



Fig.21

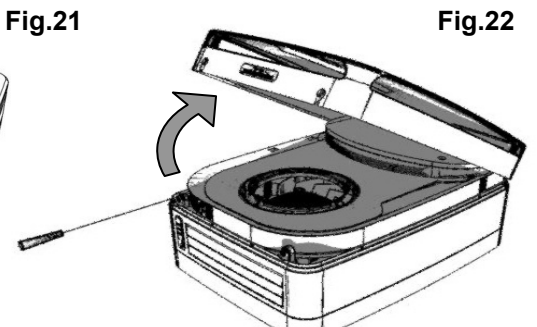

Fig.22

2. Lift where indicated
to engage hinges Fig 23
and open Door Fig 24.

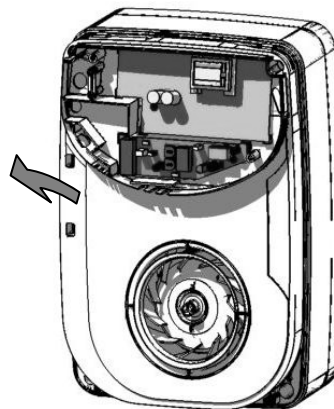

Fig.23

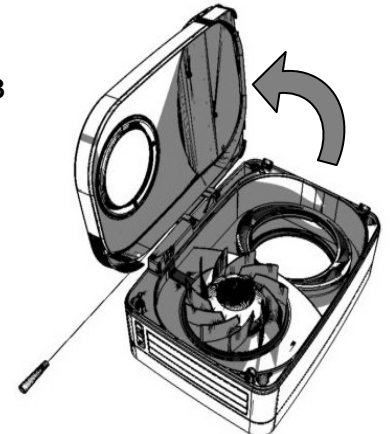

Fig.24

3. Remove Retaining Plate, Carefully slide out the Heat Exchanger Fig 25 & 26 and wash in warm water using a mild detergent, dry thoroughly and re assemble in reverse order to above.

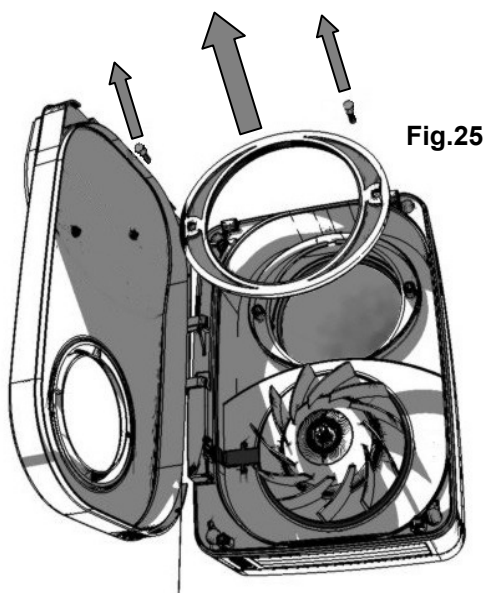

Fig.25

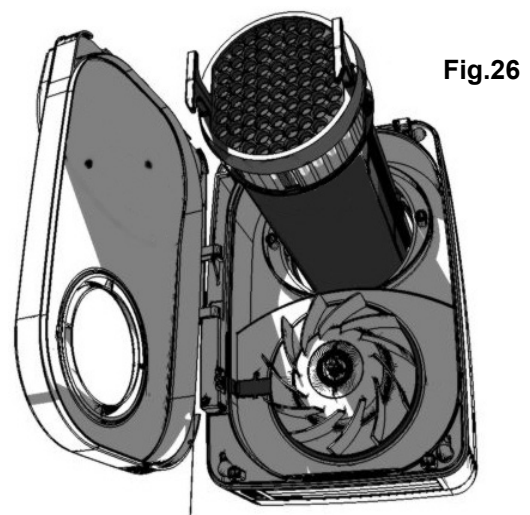

Fig.26

E. Spares

The following spares may be ordered from Vent-Axia

Item	Part No	Description	Models used
1.	445885	Heat exchanger (Short)	P, T & HTP
2.	445886	Motor chassis assembly	P, LP, T, LT, HTP & LHTP
3.	445892	SELV Cover assembly	P, LP, T, LT, HTP & LHTP
4.	444377	SELV power supply unit	P, LP, T, LT, HTP & LHTP
5.	445889	Pullcord PCB	P & LP (only)
6.	445890	Timer PCB	T & LT (only)
7.	445891	HTP PCB	HTP & LHTP (only)
8.	455630	Pullcord Assembly	P, LP, HTP & LHTP
9.	447838	Wall cover bezel	P, LP, T, LT, HTP & LHTP
10.	403878	Heat exchanger (Long)	LP, LT & LHTP

1. & 10.

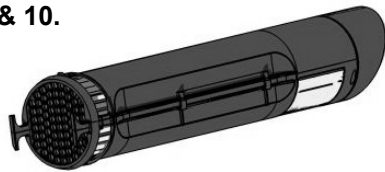

2.

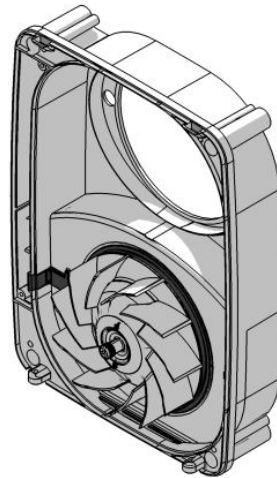

4.

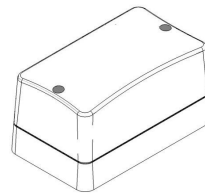

9.



3.



5. (P, LP)
6. (T, LT)
7. (HTP, LHTP)

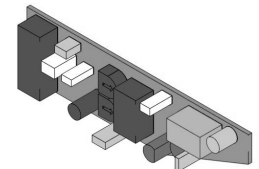

8.



The **Vent-Axia** Guarantee

Applicable only to products installed and used in the United Kingdom. For details of guarantee outside the United Kingdom contact your local supplier.

Vent-Axia guarantees its products for two years from date of purchase against faulty material or workmanship. In the event of any part being found to be defective, the product will be repaired, or at the Company's option replaced, without charge, provided that the product:-

- Has been installed and used in accordance with the instructions given with each unit.
- Has not been connected to an unsuitable electricity supply. (The correct electricity supply voltage is shown on the product rating label attached to the unit).
- Has not been subjected to misuse, neglect or damage.
- Has not been modified or repaired by any person not authorised by the company.

IF CLAIMING UNDER TERMS OF GUARANTEE

Please return the complete product, carriage paid to your original supplier or nearest Vent-Axia Centre, by post or personal visit. Please ensure that it is adequately packed and accompanied by a letter clearly marked "Guarantee Claim" stating the nature of the fault and providing evidence of date and source of purchase.

The guarantee is offered to you as an extra benefit, and does not effect your legal rights

Vent-Axia

Head Office: Fleming Way, Crawley, West Sussex, RH10 9YX.

UK NATIONAL CALL CENTRE, Newton Road, Crawley, West Sussex, RH10 9JA

SALES ENQUIRIES: Tel: 0844 8560590 Fax: 01293 565169
TECHNICAL SUPPORT: Tel: 0844 8560594 Fax: 01293 539209
Web:-www.vent-axia.com Email:- info@vent-axia.com

As part of the policy of continuous product improvement Vent-Axia reserves the right to alter specifications without notice.