

SINGLE-ROOM REVERSIBLE ENERGY RECOVERY VENTILATOR

KSRHRV100-WH

EN

USER'S MANUAL

CONTENTS

Safety requirements.....	2
Purpose.....	4
Delivery set.....	4
Technical data.....	5
Design and operating principle.....	6
Mounting and set-up.....	8
Connection to power mains.....	13
Technical maintenance.....	18
Storage and transportation regulations.....	20
Manufacturer's warranty.....	21
Certificate of acceptance.....	23
Seller information.....	23
Installation certificate.....	23
Warranty card.....	23

This user's manual is a main operating document intended for technical, maintenance, and operating staff.

The manual contains information about purpose, technical details, operating principle, design, and installation of the KSRHRV100-WH unit and all its modifications.

Technical and maintenance staff must have theoretical and practical training in the field of ventilation systems and should be able to work in accordance with workplace safety rules as well as construction norms and standards applicable in the territory of the country.

SAFETY REQUIREMENTS

All user's manual requirements as well as the provisions of all the applicable local and national construction, electrical, and technical norms and standards must be observed when installing and operating the unit.

Disconnect the unit from the power supply prior to any connection, servicing, maintenance, and repair operations.

Only qualified electricians with a work permit for electrical units up to 1000 V are allowed for installation. The present user's manual should be carefully read before beginning works.

Check the unit for any visible damage of the impeller, the casing, and the grille before starting installation. The casing internals must be free of any foreign objects that can damage the impeller blades.

While mounting the unit, avoid compression of the casing! Deformation of the casing may result in motor jam and excessive noise.

Misuse of the unit and any unauthorised modifications are not allowed.

Do not expose the unit to adverse atmospheric agents (rain, sun, etc.).

Transported air must not contain any dust or other solid impurities, sticky substances, or fibrous materials.

Do not use the unit in a hazardous or explosive environment containing spirits, gasoline, insecticides, etc.

Do not close or block the intake or extract vents in order to ensure the efficient air flow.

Do not sit on the unit and do not put objects on it.

The information in this user's manual was correct at the time of the document's preparation. The Company reserves the right to modify the technical characteristics, design, or configuration of its products at any time in order to incorporate the latest technological developments.

Never touch the unit with wet or damp hands.

Never touch the unit when barefoot.

This unit is not intended for use by persons (including children) with reduced physical, sensory or mental capabilities, or lack of experience and knowledge, unless they have been given supervision or instruction concerning use of the unit by a person responsible for their safety. Children should be supervised to ensure that they do not play with the unit.

Connection to the mains must be made through a disconnecting device, which is integrated into the fixed wiring system in accordance with the wiring rules for design of electrical units, and has a contact separation in all poles that allows for full disconnection under overvoltage category III conditions.

If the supply cord is damaged, it must be replaced by the manufacturer, its service agent, or similarly qualified persons in order to avoid a safety hazard.

Ensure that the unit is switched off from the supply mains before removing the guard.

Precautions must be taken to avoid the back-flow of gases into the room from the open flue of gas or other fuel-burning appliances.



**THE PRODUCT MUST BE DISPOSED SEPARATELY AT THE END OF ITS SERVICE LIFE.
DO NOT DISPOSE THE UNIT AS UNSORTED DOMESTIC WASTE.**

PURPOSE

The ventilator is designed to ensure continuous mechanical air exchange in flats, cottages, hotels, cafés and other domestic and public premises. The ventilator is equipped with a regenerator that enables supply of fresh filtered air heated by means of extract air heat energy recovery.

The ventilator is designed for installation on external walls.

The unit is rated for continuous operation.

DELIVERY SET

Name	Number
Indoor assembly unit of the ventilator	1 pc.
Air duct	1 pc.
Sound-absorbing material	1 pc.
Fan assembly	–
Regenerator assembly	–
Cartridge assembly	1 pc.
Outer ventilation hood	1 pc.
Remote control	1 pc.
Cardboard mounting plate	1 pc.
Mounting kit	2 packages
Mounting wedges	1 kit
User's manual	1 pc.
Mounting hood installation instruction	1 pc.
Packing box	1 pc.

TECHNICAL DATA

The temperature in the room where the indoor unit of the ventilator is installed must be in the range from +1 °C to +40 °C with relative air humidity up to 65 % (no condensation buildup).

Transported air temperature must be in the range:

from -15 °C to +40 °C for **KSRHRV100-WH** models.

If the conditions of use of the ventilator are outside the specified limits, turn off the ventilator. Provide fresh air with open windows.

The unit is rated as a class II electric appliance.

Ingress protection rating against access to hazardous parts and water ingress is IP2X.

The supplied hood model and the air duct length depend on the ventilator model (see the Designation key section).

The ventilator design is regularly improved, so some models may slightly differ from those ones described herein.

Technical specifications of the particular model are also indicated on the unit casing.



OVERALL DIMENSIONS OF THE INDOOR UNIT [MM]

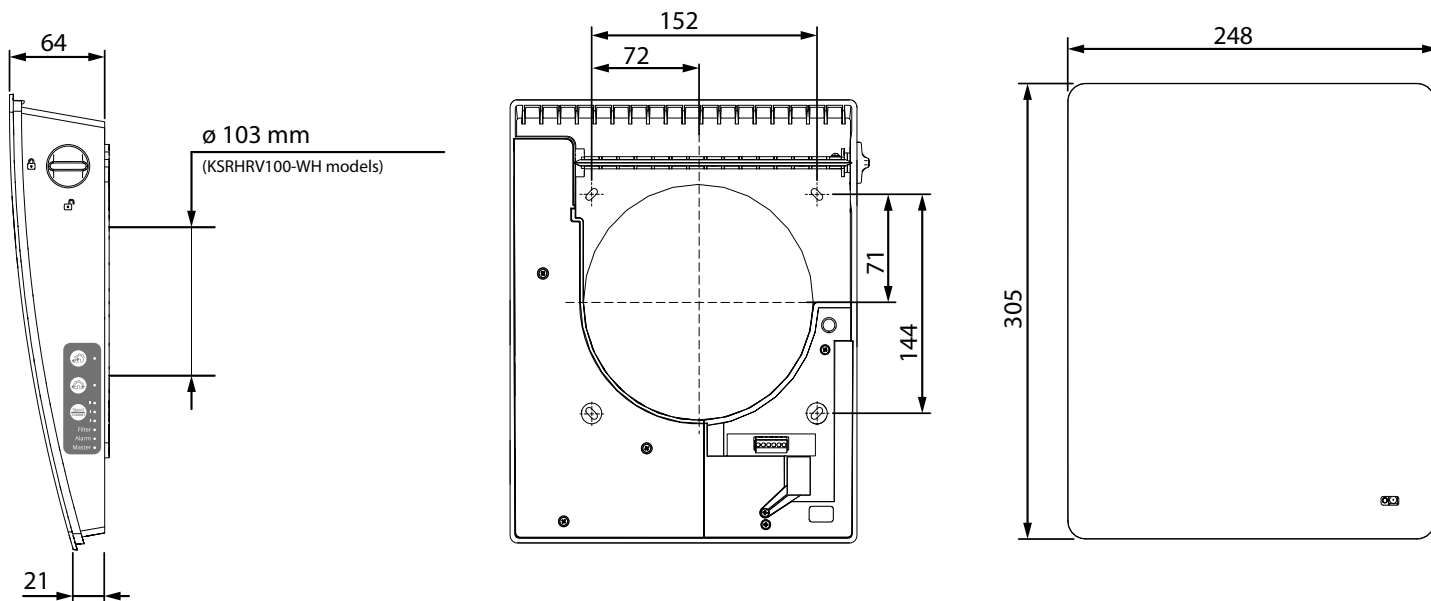

DESIGN AND OPERATING PRINCIPLE

The ventilator consists of an indoor unit with a decorative front panel, a fan unit, a regenerator unit located inside the air duct and an outer ventilation hood.

The fan unit and the regenerator unit are connected in a non-assembled cartridge.

Inside the air duct, on the air flow path, there are two filters that ensure rough air filtration and prevent ingress of dust and foreign objects into the regenerator and the fan.

In the lower right corner of the front panel of the ventilator there is a receiver window for the IR remote control combined with the light sensor. The light sensor controls the brightness of the control panel LEDs.

The LEDs are brighter during daylight hours and dim at night.

VENTILATOR DESIGN

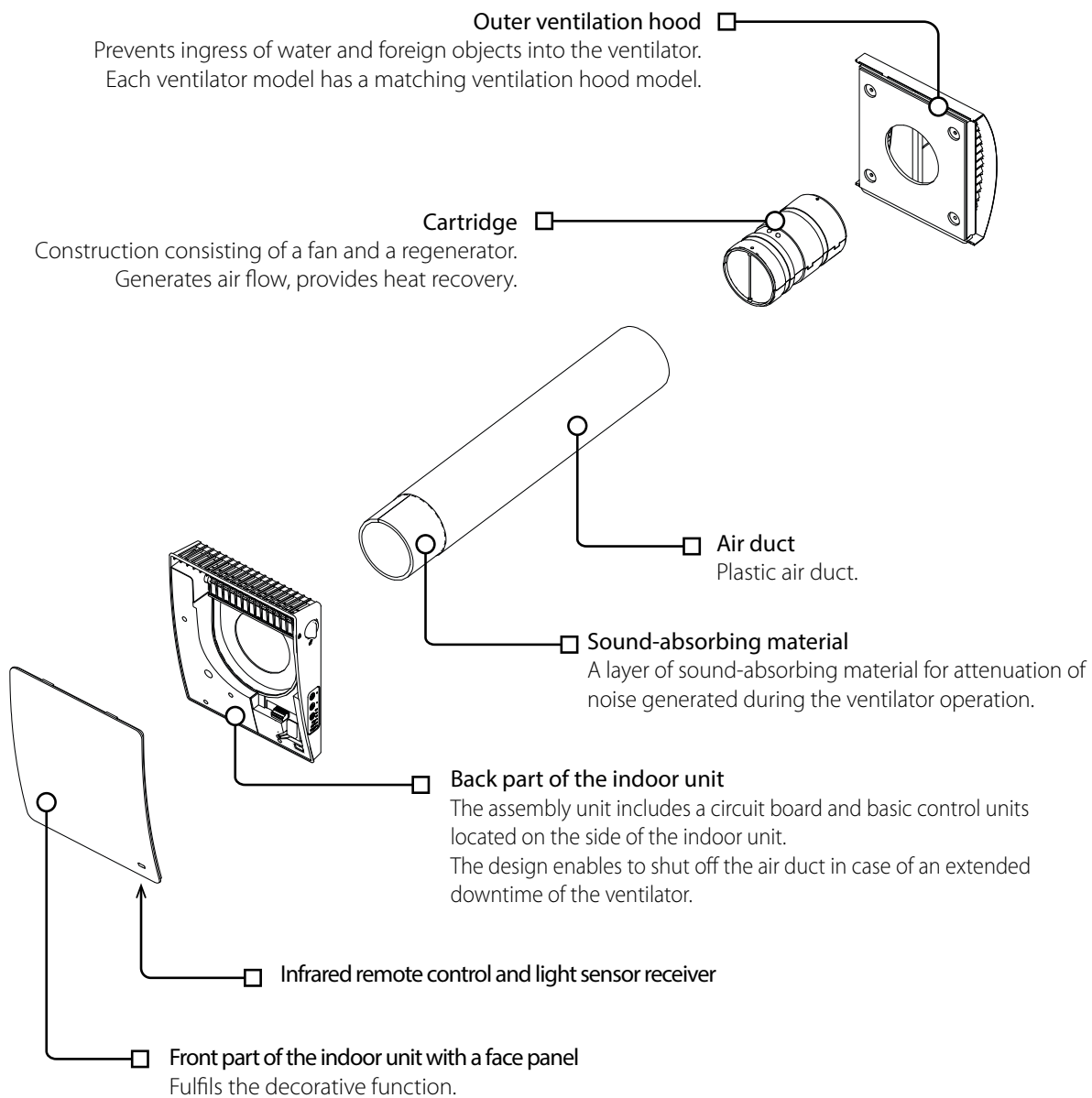

AIR DAMPER OPERATING PRINCIPLE

The indoor unit of the ventilators has a swivel damper. The vertical position of the handle corresponds to the position OPEN, the horizontal one – to the position CLOSED.

The indoor unit of the **KSRHRV100-WH** ventilators is equipped with an automatic air damper. It opens at the beginning of the ventilator's operation and lets the air flow freely through the ventilator.

After switching off the ventilator, the damper closes automatically.

The air damper opening and closing process can take up to five minutes.

Caution! If the power supply is cut off during operation of the ventilator, after five minutes, the damper can be manually moved to the CLOSED position using the handle to prevent drafts.

Later on, when the ventilator is turned on, the damper will automatically open.

Caution! Air damper opening or closing does not turn the ventilator on or off!

The figure below shows the closed and open positions of the damper and the handle.

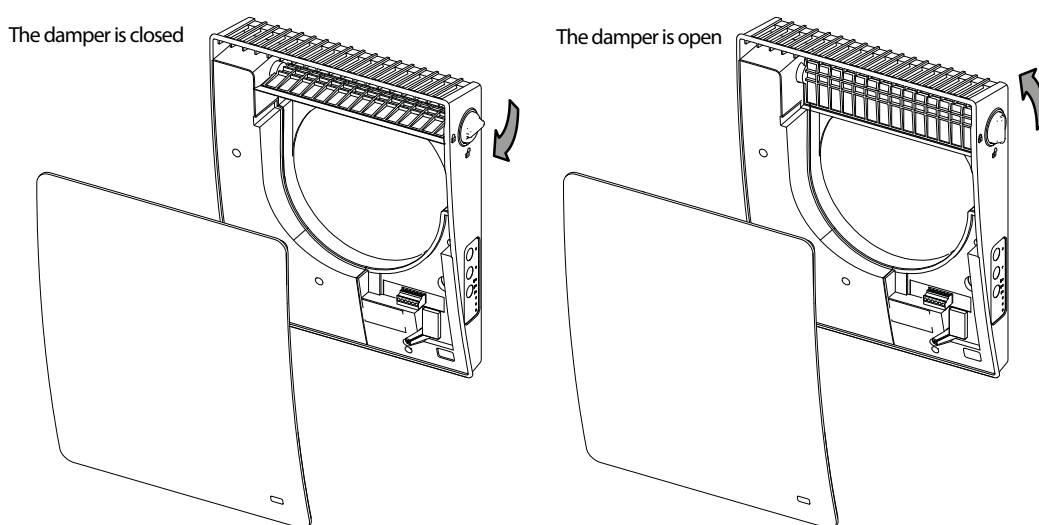
**VENTILATOR OPERATION MODES**

Ventilation: the ventilator runs either in the air extraction or air supply mode at a set speed.

In this mode some of the ventilators in the network run in the air supply mode and the other ones in the air extraction mode, depending on the position of the DIP switch No. 3 (see section **Setting the ventilator operation mode using DIP switches**).

Boost: when the set humidity value is exceeded or when the NO-contact of the external relay sensor is closed, the ventilator switches to third speed until the sensors return to their standard state and the Boost mode deactivation timer expires.

Regeneration: the ventilator runs in two cycles, 70 seconds each, with heat and humidity regeneration.

Cycle I. Warm stale air is extracted from the room and flows through the ceramic regenerator, which gradually absorbs heat and humidity. In 70 seconds, as the ceramic regenerator gets warmed, the ventilator is switched to the supply mode.

Cycle II. Fresh intake air from outside flows through the ceramic regenerator, absorbs accumulated moisture and is heated up to the room temperature. In 70 seconds, as the ceramic regenerator gets cooled down, the ventilator is switched to the air extraction mode and the cycle is renewed.

The interval from which a particular ventilator starts operation depends on the position of DIP-switch No. 3. When installing two or an even number of ventilators, they must be configured to operate in reverse phase. While one ventilator supplies air, the other one extracts it.

MOUNTING AND SET-UP

 **READ THE USER'S MANUAL BEFORE INSTALLING THE UNIT.**

 **DO NOT BLOCK THE AIR DUCT OF THE INSTALLED VENTILATOR WITH DUST ACCUMULATING MATERIALS, SUCH AS CURTAINS, CLOTH SHUTTERS, ETC. AS IT PREVENTS AIR CIRCULATION IN THE ROOM.**

The figure below shows a schematic layout of the ventilator's internal elements depending on the wall thickness. The ability to mount the ventilator in the wall depends on the length of the internal elements and the required protrusion A.

The length of the internal elements, the diameter of the required opening and the minimum wall thickness in which the ventilator can be installed when using different external ventilation hoods are shown in the table below.

KSRHRV100-WH

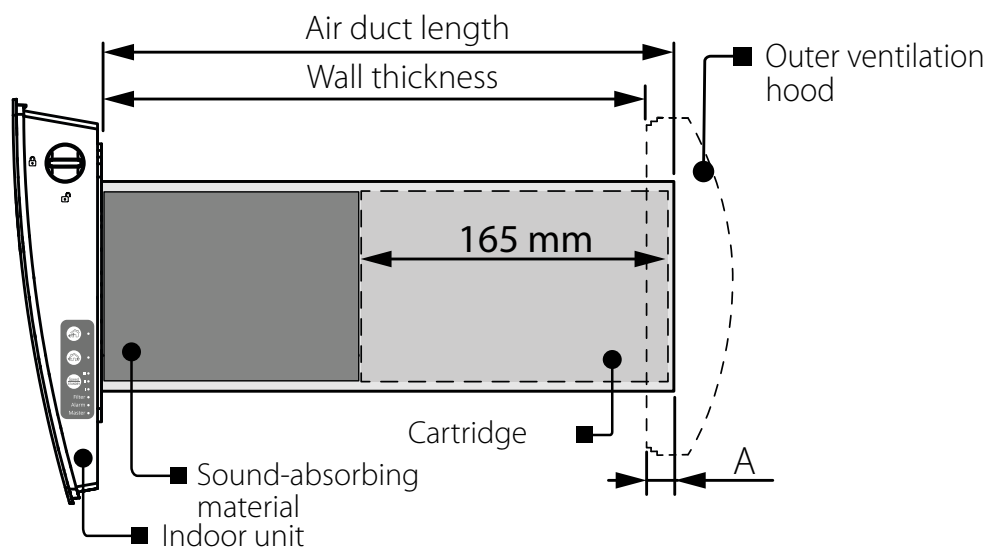

Reference dimensions for installation of ventilators	KSRHRV100-WH
Length of cartridge or fan and regenerator units [mm]	165
Hole diameter D [mm]	120
Minimum possible wall thickness when using EH, EH-14, EH-13, EH-17, MWM hoods (mm)	from 155
Minimum possible wall thickness when using an EH-2 hood (mm)	from 55

1. Prepare a round core hole in the outer wall.

The figure below shows the minimum distance from the hole to the surrounding objects.

The hole diameter depends on the specific ventilator model. The corresponding values are given in the table.

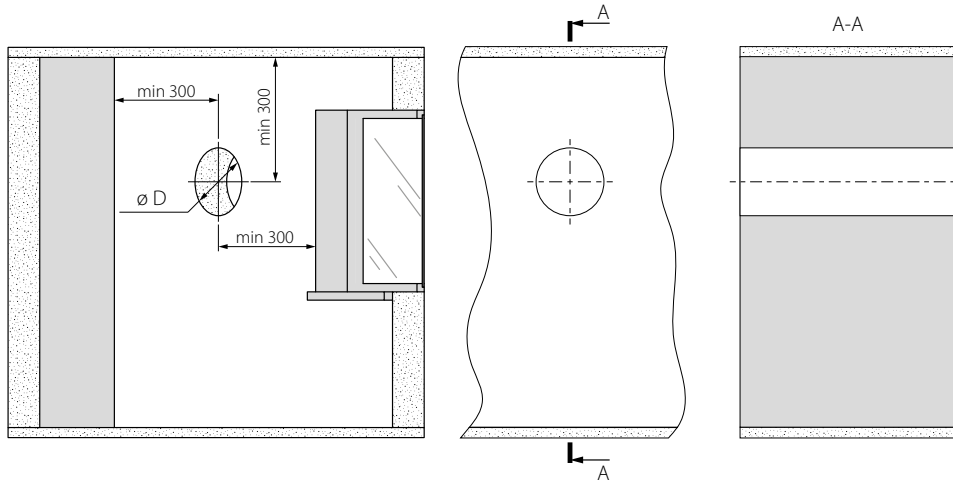

2. Insert the air duct in the wall. For ease of installation use the mounting wedges included in the delivery set.

The air duct end must protrude for the distance A that enables installation of the outer ventilation hood. The overall dimensions of the outer ventilation hood, the outside protrusion length of the air duct A and the mounting sequence of the hood are stated in its installation instruction.

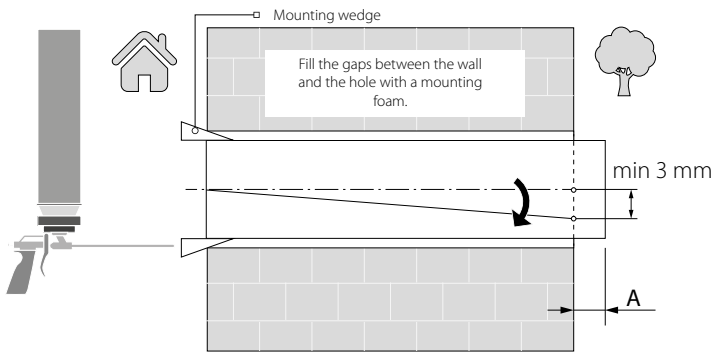

Install the air duct with the minimum slope of 3 mm downwards from the outer wall side.

The air duct can be cut by calculating preliminary the required length or after fixing the air duct on the wall (in this case, it is necessary to have access to the outside part of the wall).

3. Install the outer ventilation hood. The mounting sequence of the outer ventilation hood is described in the installation instruction for the ventilation hood.

4. Stick the delivered cardboard master plate on the indoor wall using a mounting tape. The large opening in the master plate must be axially aligned with the air duct. Align the master plate horizontally with a building level.

Then mark the fastening holes for installation of the supplied dowels and drill the holes to a required depth.

Route the power cable from the wall through the marked opening on the template.

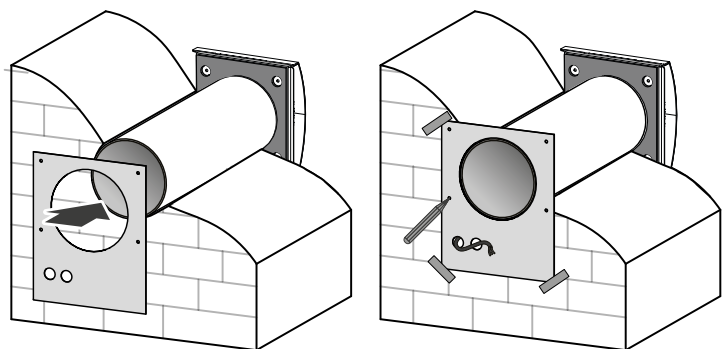

Hole marking for unit fastening

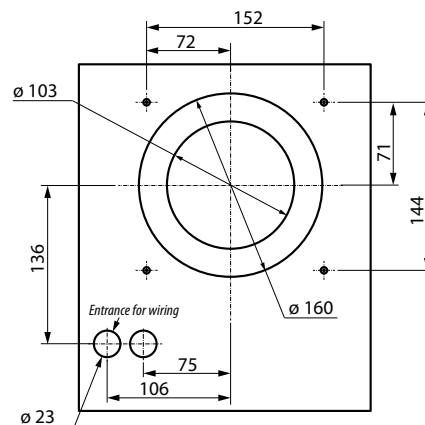

5. Separate the front panel of the indoor unit from its back part. To do this, use a flat screwdriver to unhook the latches securing the front panel and open it as shown in the figure below.

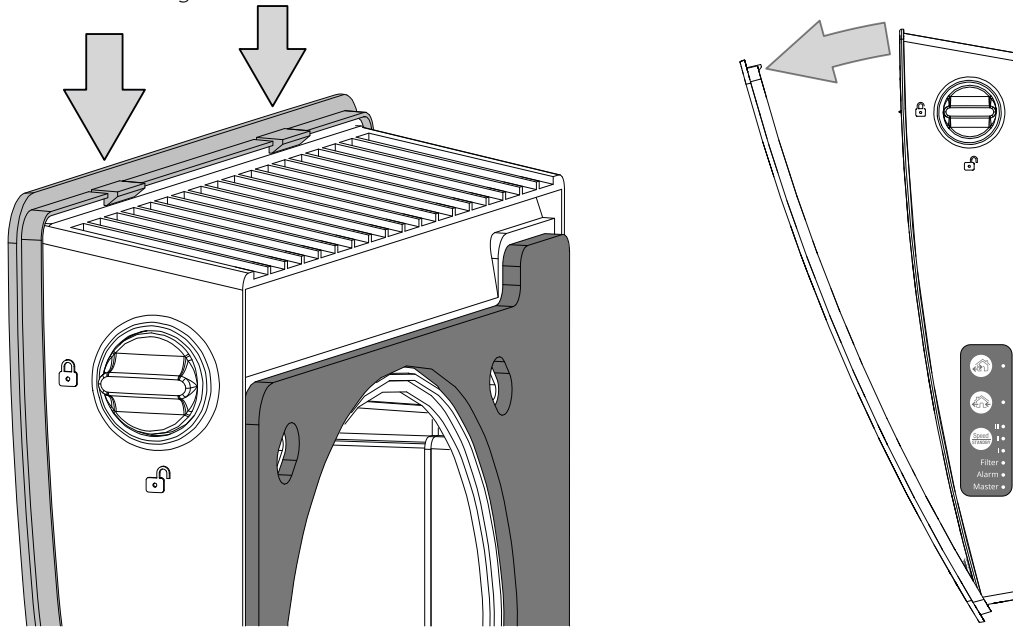

6. Remove the three retaining screws from the left cover to enable access to the terminals. Route the power wires through the appropriate cable glands.

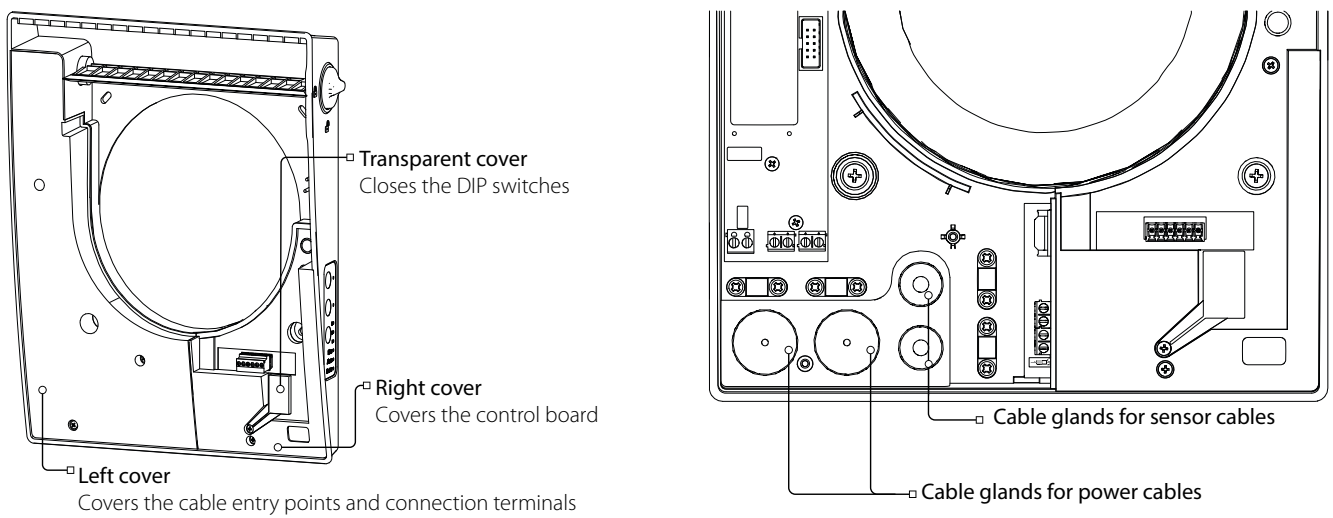

7. Fix the back part of the indoor unit on the wall with the screws supplied with the mounting kit of the ventilator.

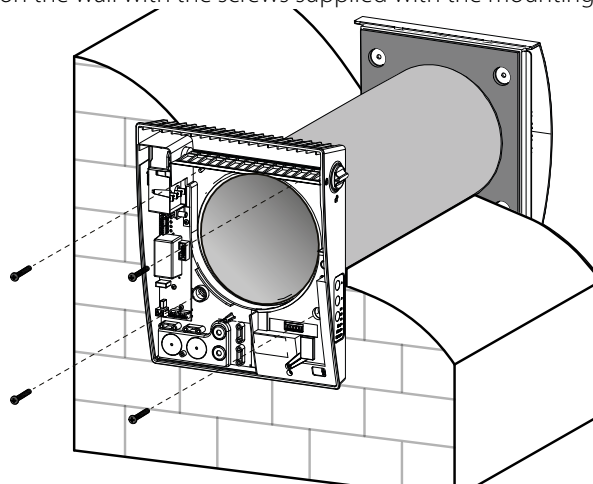

8. Route the power cable as figured below and connect the ventilator to power mains in compliance with the external wiring diagram, see section **Connection to power mains**. Secure the power cable with the clamp.

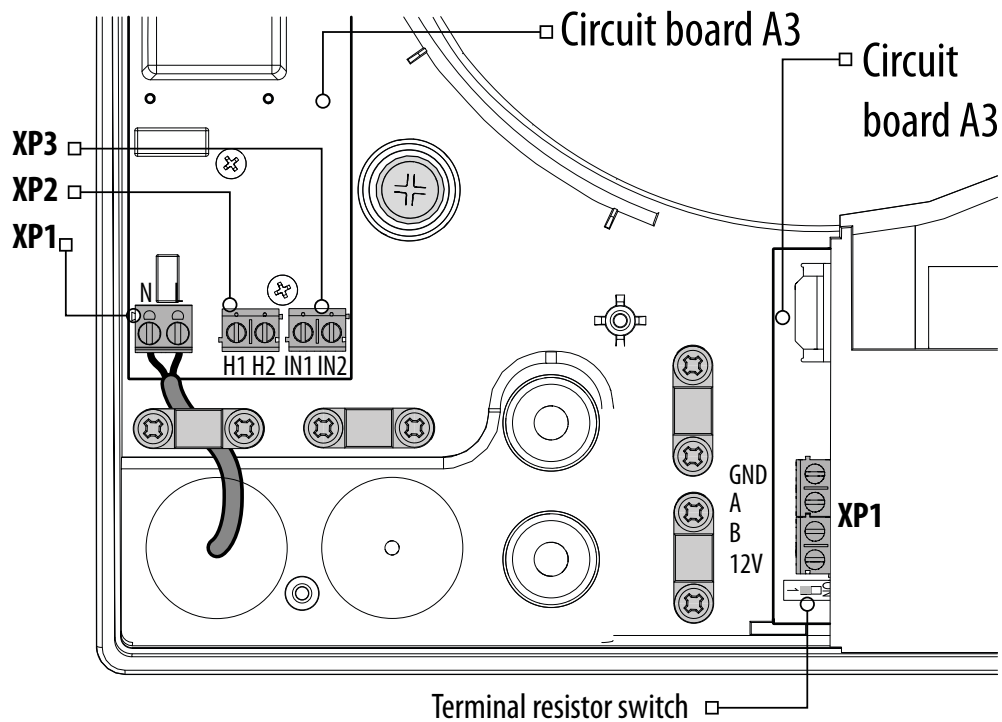

9. After completion of the electrical connection reinstall the left cover in site.

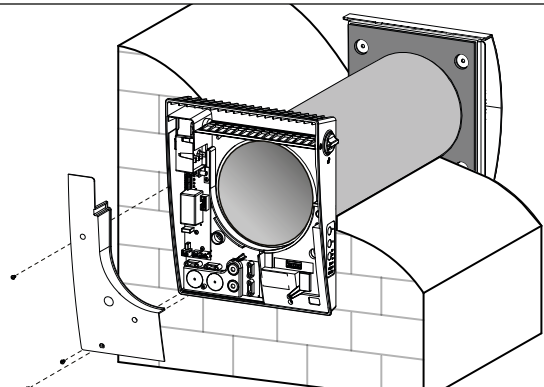

10. Install the cartridge or the regenerator unit and the fan unit into the air duct as figured below and connect the connector to the board. Insert the sound-absorbing layer in the air duct. Roll the layer of the sound absorbing material to match the air duct diameter. The protecting paper layer must be outside. Insert the sound absorbing roll into the cartridge against stop. Make a mark at the end of the air duct, remove the material and cut the roll as marked. Insert the ready sound absorbing roll into the air duct.

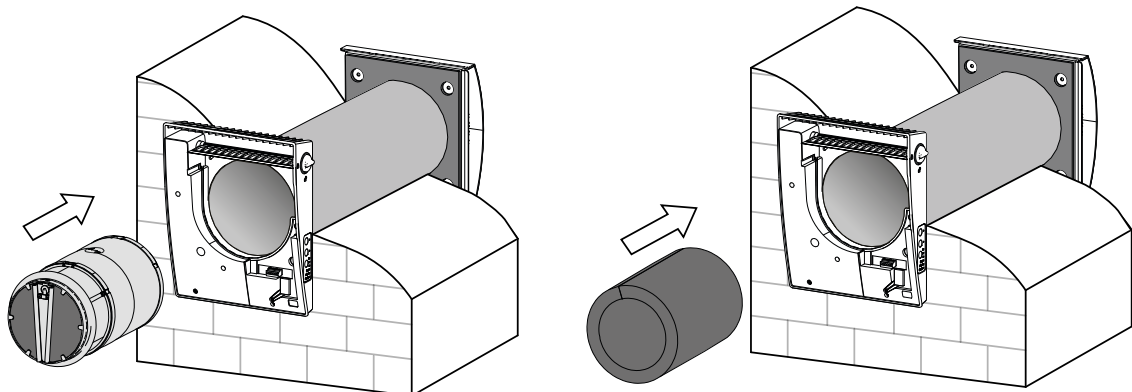

11. Install the front panel of the indoor unit.

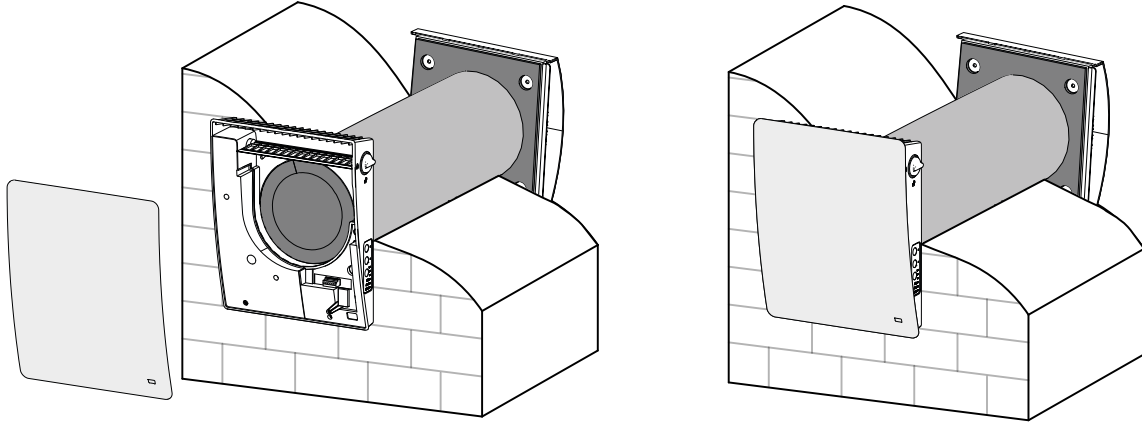

CONNECTION TO POWER MAINS



**POWER OFF THE POWER SUPPLY PRIOR TO ANY OPERATIONS WITH THE UNIT.
THE UNIT MUST BE CONNECTED TO POWER SUPPLY BY A QUALIFIED ELECTRICIAN.
THE RATED ELECTRICAL PARAMETERS OF THE UNIT ARE GIVEN ON THE
MANUFACTURER'S LABEL.**

The ventilator is rated for connection to single-phase AC 100-240 V 50/60 Hz power mains.

For electric installations use insulated, flexible conductors (cables, wires) with the minimum cross section of 0.5 up to 0.75 mm² for power cables and 0.25 mm² for signal cables and sensor cables. The cable cross section is given for reference only. The actual conductor cross-section selection must be based on its type, maximum permissible heating, insulation, length and installation method.

Use copper wires for all the electric connections!

Connect the unit to power mains via the terminal block installed in the power board (A3) in compliance with the wiring diagram and terminal designation.

Connect the unit to power mains via the terminal block installed in the power board (A3) in compliance with the wiring diagram and terminal designation. Connect the ventilator to power mains through an automatic circuit breaker with magnetic trip integrated into the home wiring system. The tripping current of the circuit breaker is selected based on the electrical characteristics shown on the label of the fan casing. The ventilator design enables connecting any external controls with a normally opened contact (NO contact), such as an external CO₂ sensor, a humidity sensor, a switch, etc.

When the no-contact of the external relay sensor is closed, the unit changes to the third speed. Upon the opening of the NO-contact the Boost turn-off delay timer is activated. When the timer elapses, the ventilator reverts to the previous speed setting.

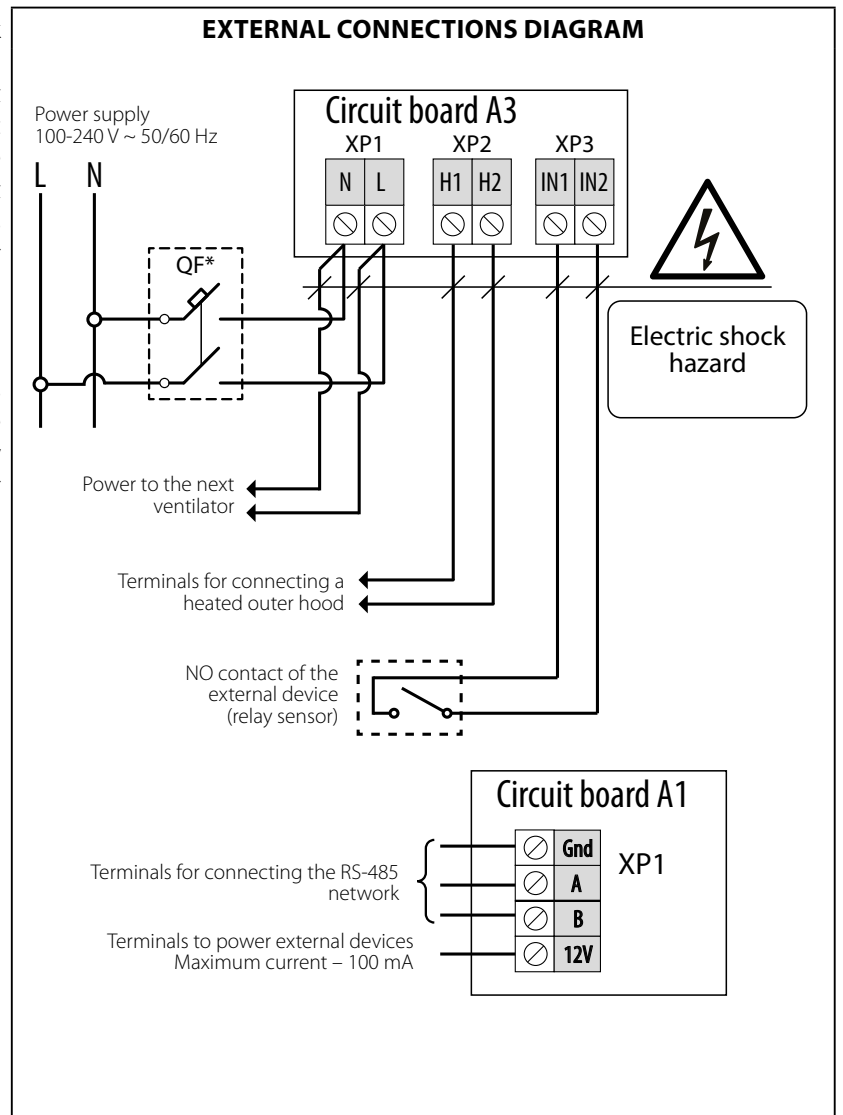

*The circuit breaker is not included in the delivery set and can be ordered separately.

CONNECTION OF VENTILATORS TO A SINGLE NETWORK

Connection of ventilators to a single network

For coordinated control of several ventilators, they must be connected to a single network.

All devices in the RS-485 network must be connected using the Bus topology.

There can be only one ventilator with the Master setting and up to 15 ventilators with the Slave setting in the network. If two or more ventilators in the network are accidentally activated in the Master mode, the error will be accompanied by short beeps.

It is not recommended to use an RS-485 bus cable longer than 200 m.

The connection diagram is shown below.

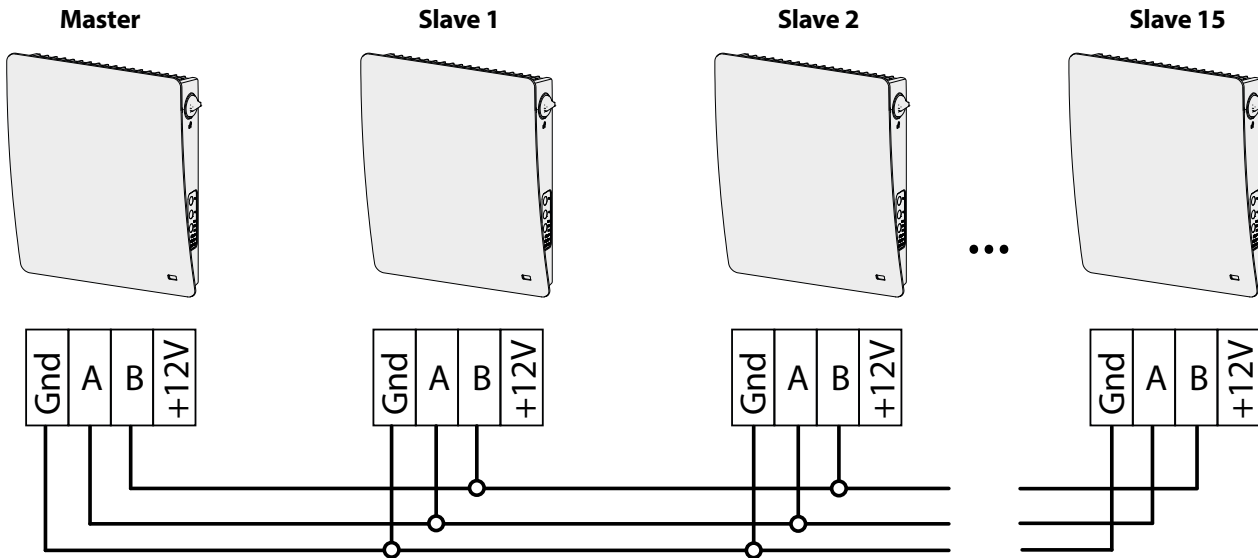

WARNING! Never connect + 12V power lines from multiple devices!

SETTING THE DIP SWITCH POSITION OF THE TERMINAL RESISTOR

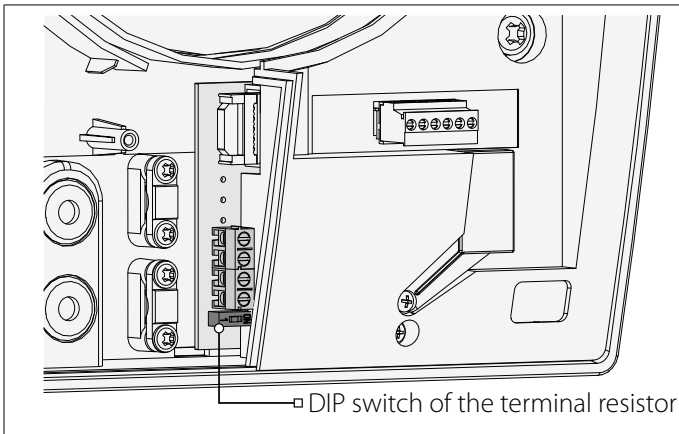

The DIP switch of the terminal resistor must be in ON position if the ventilator is the first or the last in the RS-485 network.

VENTILATOR CONTROL



The ventilator is operated with:

- infra-red remote control
- control buttons located on the side of the indoor unit (see the figure below)

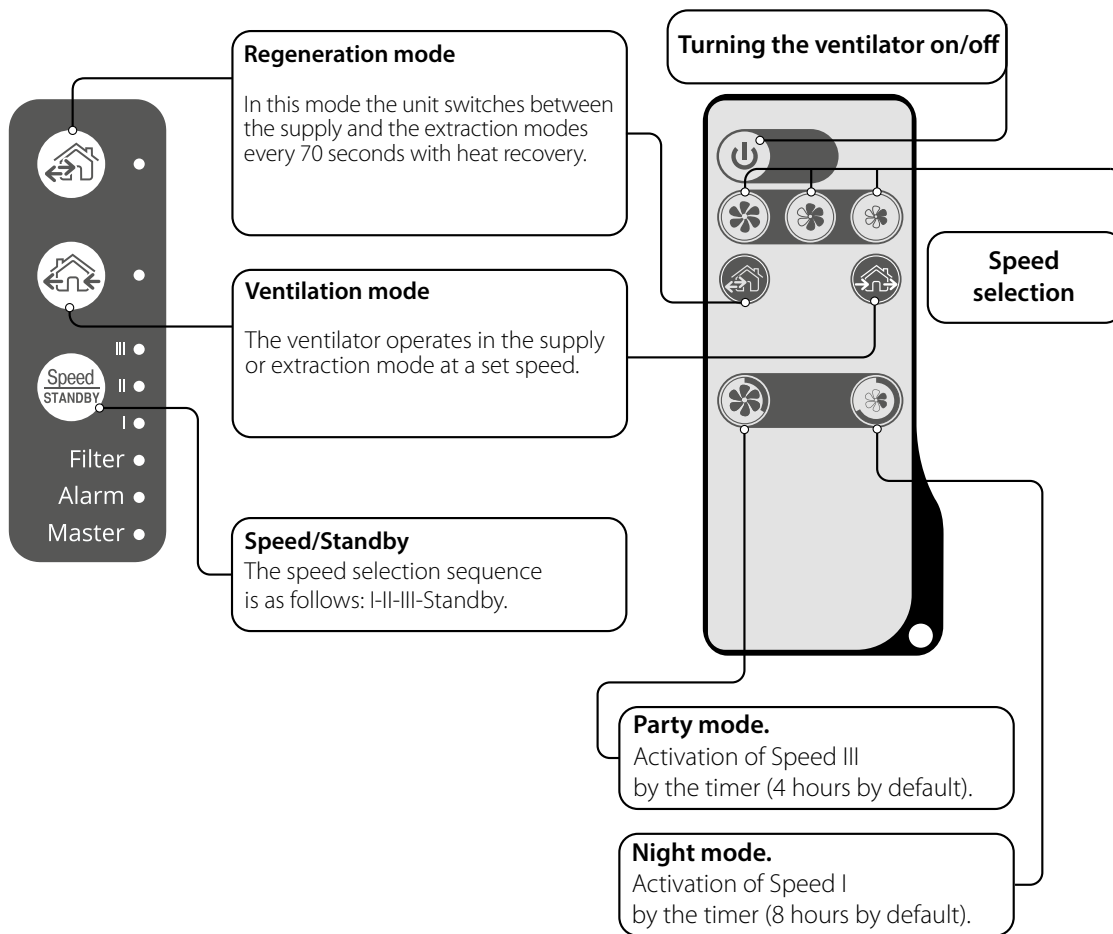
Description of the buttons on the indoor unit and remote control



Description of the buttons on the indoor unit







	<p>The speed selection sequence is as follows: I-II-III-Standby. All the units integrated in a single network operate according to the speed settings of the Master unit.</p> <p>I: permanent indicator glowing indicates operation of the unit at Speed I. Indicator blinking indicates activation of the Night mode timer.</p> <p>I and II: permanent glowing of these indicators indicates operation of the unit at Speed II.</p> <p>I, II and III: permanent glowing of these indicators indicates operation of the ventilation unit at Speed III. Synchronous blinking of the indicators I, II and III indicates activation of the timer in the Party mode or the turn-off delay timer in the Boost mode in case of actuation of the connected external sensors or the integrated humidity sensor.</p>
	<p>Regeneration mode</p> <p>The rotation direction of both fans changes to opposite every 70 seconds. Heat recovery is performed in this mode. To enable reverse phase operation of the ventilators, change the position of the DIP switch No. 3.</p>

	<p>Ventilation mode The ventilator operates in the supply or extraction mode at a set speed. The fan rotation direction depends on the position of the DIP switch No. 3.</p> <p>Resetting to factory settings To reset all parameters to the factory settings, hold this button on the indoor unit of the master ventilator for 5 seconds until a beep sounds.</p>
--	--

Indicators on the indoor unit

Filter	<p>90 days after installation of the cartridge the filter replacement indicator starts glowing. In this case, clean or replace the filters (see section Technical maintenance).</p> <p>After replacement of the filters reset the timer by pressing and holding the  button on the master ventilator indoor unit for 5 seconds until a signal sounds.</p>
Alarm	<p>Alarm indicator. In case of failure, the Alarm indicator on the indoor unit glows or blinks.</p> <p>If several interconnected ventilators are running in the same network, in case of alarm shutdown of the ventilator, all of the ventilators of this network also stop. The alarm indicator blinks on the defective ventilator and glows on the other connected ventilators.</p>
Master	<p>Permanent glowing of the indicator shows the leading unit in the network (Master unit).</p> <p>Indicator blinking indicates the Slave unit and no connection to the Master unit.</p> <p>No glowing of the lamp indicator means that this ventilation unit is a Slave ventilation unit and it is connected to a Master unit.</p>

Description of the buttons on the remote control

	<p>ON/Standby. The Standby mode depends on the position of the DIP switch 2 (see section Setting the ventilator operation mode using DIP switches). The same button is used to reset alarms (Alarm) and to turn off the timers.</p>
	<p>Ventilator speed selection: Speed III-II-I respectively.</p>
	<p>Regeneration mode The rotation direction of both fans changes to opposite every 70 seconds. Heat recovery is performed in this mode. The fan rotation direction depends on the position of the DIP switch 3.</p>
	<p>Ventilation mode The ventilator operates in the supply or extraction mode at a set speed. The fan rotation direction depends on the position of the DIP switch No. 3.</p>
	<p>Timer control buttons:</p> <ul style="list-style-type: none">  Party mode: the timer activates operation of the unit at Speed III for 4 hours.  Night mode: the timer activates operation of the unit at Speed I for 8 hours. <p>The ventilation unit reverts to operation with a previous speed setting upon elapse of the set time period. Press any speed setting key to deactivate the timer or press the timer control button once again.</p>

When several mutually exclusive operation modes are used simultaneously, the ventilator selects the mode in the following order as the priority decreases:

1. Night mode timer or Party mode timer.
2. Standby.
3. Boost mode.
4. Regular mode.

TECHNICAL MAINTENANCE



DISCONNECT THE UNIT FROM POWER SUPPLY BEFORE ANY MAINTENANCE OPERATIONS!
MAKE SURE THE UNIT IS DISCONNECTED FROM POWER MAINS BEFORE REMOVING THE PROTECTION

Maintenance of the ventilator means regular cleaning of the ventilator surfaces of dust and cleaning and replacement of the filters. To enable access to the main units, follow the procedure described below. The ventilator must be previously turned off using the remote control or the buttons on the indoor unit. Then turn off power supply completely.

1. Remove the front part of the indoor control unit as shown in step 5 of the **Mounting and Set-up** section. Move the air damper to the open position using the handle.

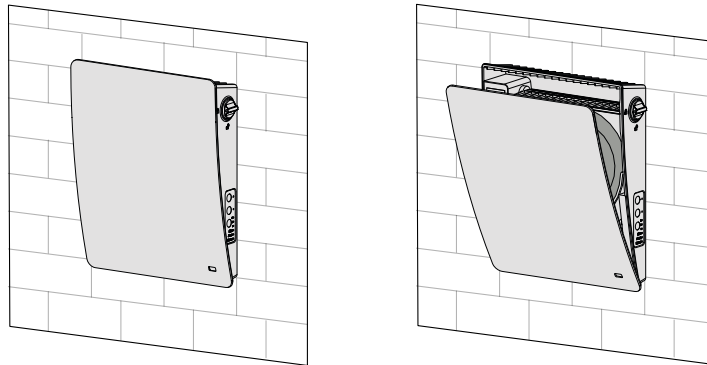

2. Disconnect the connector from the circuit board. Do not remove the connector by pulling the wires. Use a flat screwdriver to uplift it, if required.

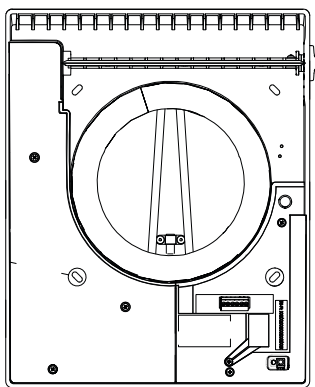

Do not pull on the electric cable.

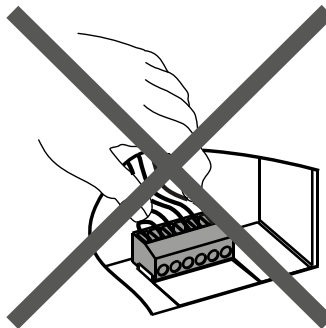

Use a flat screwdriver to disconnect the socket.

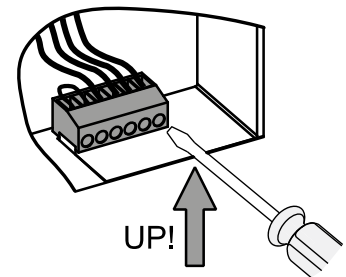

3. Remove the sound-insulation material from the duct, then remove the cartridge or the fan unit and the regenerator unit.

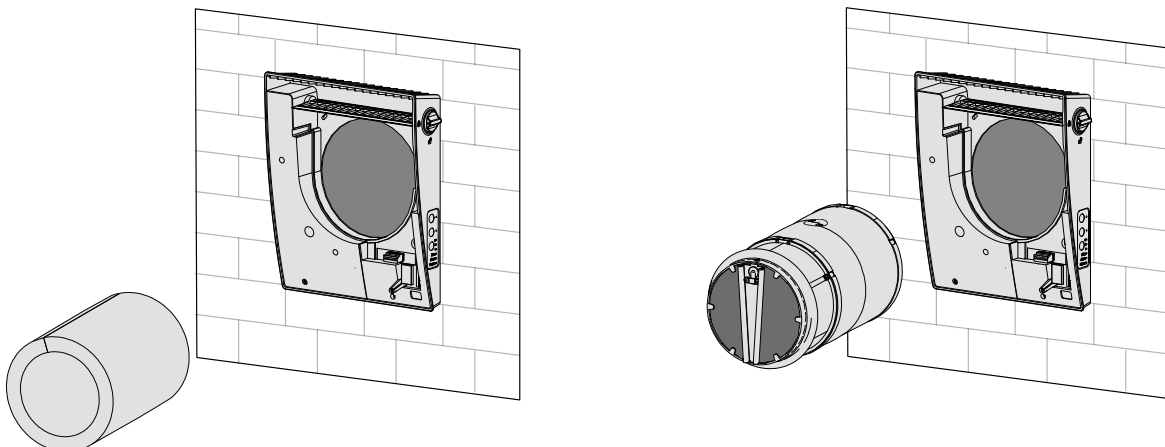

Clean the filters as they get clogged, but not less than once in three months.

- On the expiry of 90 days the filter replacement indicator (Filter) starts glowing.
- Wash the filters and let those dry out completely. Install the dry filters in their place and assemble the unit in the reverse order.
- Vacuum cleaning is allowed.
- The filter rated service life is 3 years.

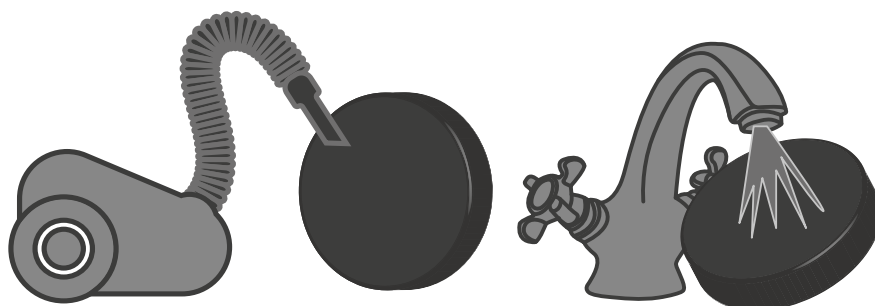

Some dust may accumulate on the regenerator block even in case of regular maintenance of the filters.

- Clean the regenerator regularly to ensure its high heat recovery efficiency.
- Vacuum clean the regenerator not less than once a year.

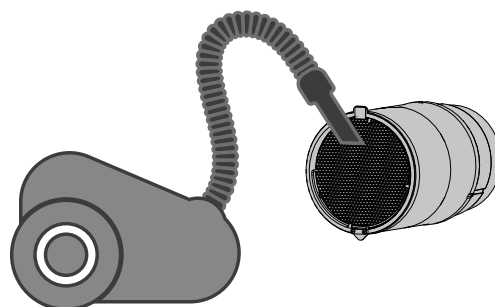

4. Replacement of the remote control battery (if necessary).

In case of a long operation of the remote control the battery must be replaced.

No response of the unit for pressing the remote control buttons indicates the need to replace the battery.

The battery type is CR2025.

Remove the holder with the battery from the lower part of the remote control.

Replace the battery and install the holder with a new battery back to the remote control.

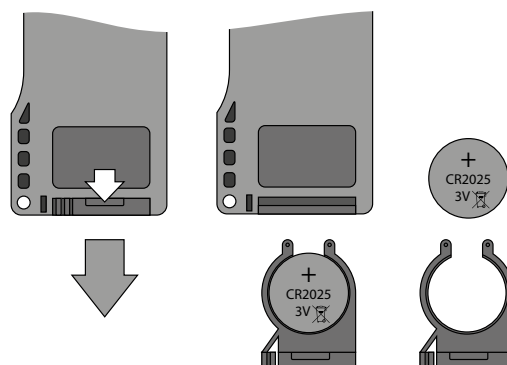

POSSIBLE REASONS AND TROUBLESHOOTING

Problem	Possible reasons	Troubleshooting
When switching on the ventilator, the fan does not start.	No power supply.	Make sure the power supply line is connected correctly, otherwise troubleshoot a connection error.
	The motor is jammed, the impeller blades are soiled.	Turn the ventilator off. Troubleshoot the motor jam and impeller clogging. Clean the blades. Turn the ventilator on.
Circuit breaker tripping during the ventilation unit start-up.	Overcurrent as a result of short circuit in the electric line.	Turn the ventilator off. Contact the Seller for further information.
Low air flow.	Low set fan speed.	Set higher speed.
	The filters, the fan or the regenerator are clogged.	Clean or replace the filter. Clean the fan and the regenerator.
Noise, vibration.	The impeller is clogged.	Clean the impeller.
	Loose screw connection of the unit casing or the outer ventilation hood	Tighten the screws of the ventilator or the outer ventilation hood.

STORAGE AND TRANSPORTATION REGULATIONS

- Store the unit in the manufacturer's original packaging box in a dry closed ventilated premise with temperature range from +5 °C to + 40 °C and relative humidity up to 70 %.
- Storage environment must not contain aggressive vapors and chemical mixtures provoking corrosion, insulation, and sealing deformation.
- Use suitable hoist machinery for handling and storage operations to prevent possible damage to the unit.
- Follow the handling requirements applicable for the particular type of cargo.
- The unit can be carried in the original packaging by any mode of transport provided proper protection against precipitation and mechanical damage. The unit must be transported only in the working position.
- Avoid sharp blows, scratches, or rough handling during loading and unloading.
- Prior to the initial power-up after transportation at low temperatures, allow the unit to warm up at operating temperature for at least 3-4 hours.

MANUFACTURER'S WARRANTY

The product is in compliance with EU norms and standards on low voltage guidelines and electromagnetic compatibility. We hereby declare that the product complies with the provisions of Electromagnetic Compatibility (EMC) Directive 2014/30/EU of the European Parliament and of the Council, Low Voltage Directive (LVD) 2014/35/EU of the European Parliament and of the Council and CE-marking Council Directive 93/68/EEC. This certificate is issued following test carried out on samples of the product referred to above.

The manufacturer hereby warrants normal operation of the unit for 24 months after the retail sale date provided the user's observance of the transportation, storage, installation, and operation regulations. Should any malfunctions occur in the course of the unit operation through the Manufacturer's fault during the guaranteed period of operation, the user is entitled to get all the faults eliminated by the manufacturer by means of warranty repair at the factory free of charge. The warranty repair includes work specific to elimination of faults in the unit operation to ensure its intended use by the user within the guaranteed period of operation. The faults are eliminated by means of replacement or repair of the unit components or a specific part of such unit component.

The warranty repair does not include:

- routine technical maintenance
- unit installation/dismantling
- unit setup

To benefit from warranty repair, the user must provide the unit, the user's manual with the purchase date stamp, and the payment paperwork certifying the purchase. The unit model must comply with the one stated in the user's manual. Contact the Seller for warranty service.

The manufacturer's warranty does not apply to the following cases:

- User's failure to submit the unit with the entire delivery package as stated in the user's manual including submission with missing component parts previously dismantled by the user.
- Mismatch of the unit model and the brand name with the information stated on the unit packaging and in the user's manual.
- User's failure to ensure timely technical maintenance of the unit.
- External damage to the unit casing (excluding external modifications as required for installation) and internal components caused by the user.
- Redesign or engineering changes to the unit.
- Replacement and use of any assemblies, parts and components not approved by the manufacturer.
- Unit misuse.
- Violation of the unit installation regulations by the user.
- Violation of the unit control regulations by the user.
- Unit connection to power mains with a voltage different from the one stated in the user's manual.
- Unit breakdown due to voltage surges in power mains.
- Discretionary repair of the unit by the user.
- Unit repair by any persons without the manufacturer's authorization.
- Expiration of the unit warranty period.
- Violation of the unit transportation regulations by the user.
- Violation of the unit storage regulations by the user.
- Wrongful actions against the unit committed by third parties.
- Unit breakdown due to circumstances of insuperable force (fire, flood, earthquake, war, hostilities of any kind, blockades).
- Missing seals if provided by the user's manual.
- Failure to submit the user's manual with the unit purchase date stamp.
- Missing payment paperwork certifying the unit purchase.



FOLLOWING THE REGULATIONS STIPULATED HEREIN WILL ENSURE A LONG AND TROUBLE-FREE OPERATION OF THE UNIT.



USER'S WARRANTY CLAIMS SHALL BE SUBJECT TO REVIEW ONLY UPON PRESENTATION OF THE UNIT, THE PAYMENT DOCUMENT AND THE USER'S MANUAL WITH THE PURCHASE DATE STAMP.

CERTIFICATE OF ACCEPTANCE

Unit Type	Single-room reversible energy recovery ventilator
Model	
Serial Number	
Manufacture Date	
Quality Inspector's Stamp	

SELLER INFORMATION

Seller	
Address	
Phone Number	
E-mail	
Purchase Date	
This is to certify acceptance of the complete unit delivery with the user's manual. The warranty terms are acknowledged and accepted.	
Customer's Signature	

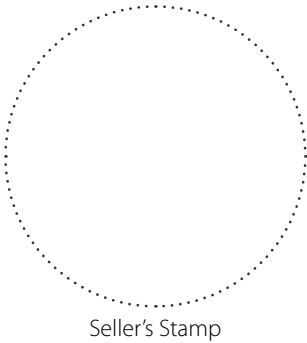

Seller's Stamp

INSTALLATION CERTIFICATE

The _____ unit is installed pursuant to the requirements stated in the present user's manual.	
Company name	
Address	
Phone Number	
Installation Technician's Full Name	
Installation Date:	Signature:
The unit has been installed in accordance with the provisions of all the applicable local and national construction, electrical and technical codes and standards. The unit operates normally as intended by the manufacturer.	
Signature:	

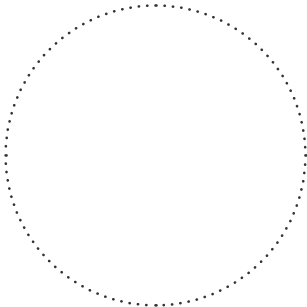

Installation Stamp

WARRANTY CARD

Unit Type	Single-room reversible energy recovery ventilator
Model	
Serial Number	
Manufacture Date	
Purchase Date	
Warranty Period	
Seller	

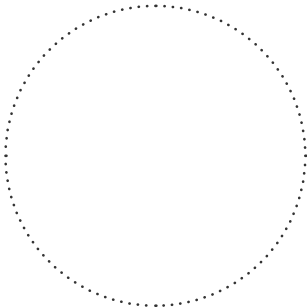

Seller's Stamp

