



Unit 6 Chiltonian
203 Manor Lane
Lee, London
SE12 0TX

SALES: 0208 463 9696
FAX: 08456 44 60 02
EMAIL: sales@i-sells.co.uk
WEB: http://www.i-sells.co.uk

NUAIRE'S EXTRACT FANS

230V & 12V Single Speed Fans

The Nuaire slimline range of axial fans incorporates 12 models complete with fixed back draft shutters.

The fans have been specifically designed to ventilate small rooms such as toilets, bathrooms, shower rooms, utility rooms and kitchens and are ideal for wall, ceiling or panel installation. The units extract directly to outside or through a short length of ducting.



Mounting Options

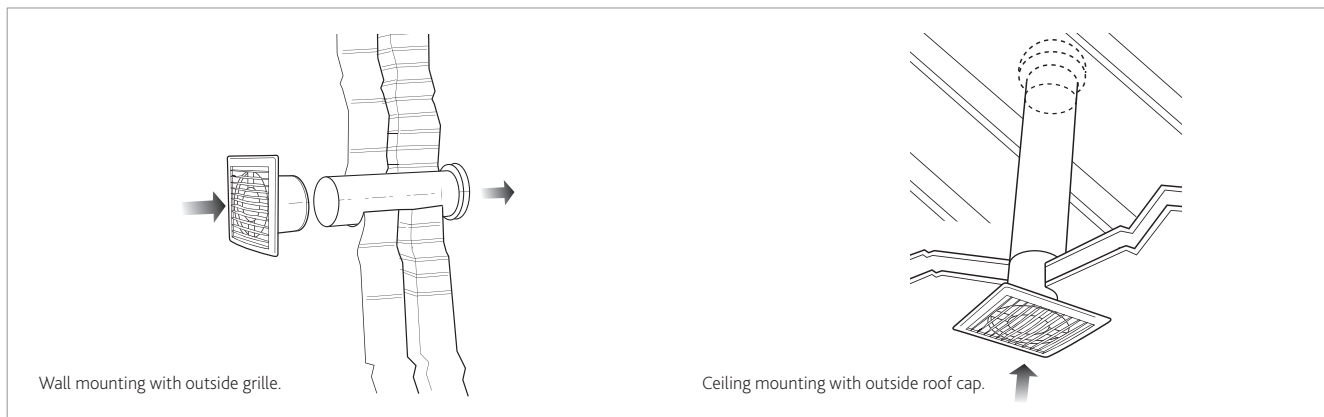

230V & 12V Twin Speed Fans

The Nuaire range of SELV and 2 speed axial fans incorporates 3 models.

They are ideal for ventilating small rooms such as toilets, bathrooms, cloakrooms and kitchens etc and can be installed on wall, ceiling, panel or window.

Window Kit Code: NA 100-WK



Mounting Options

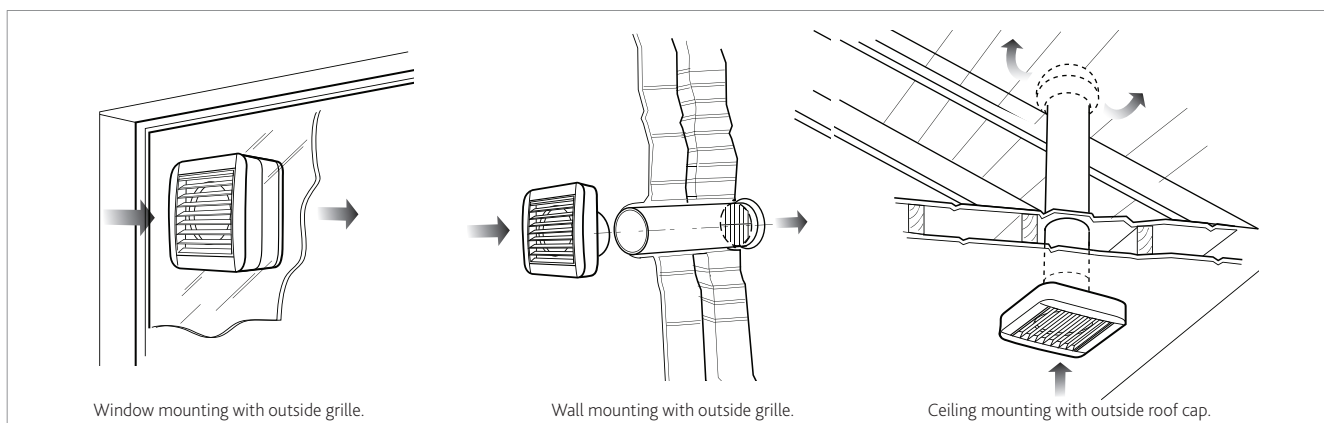

Performance - Single Speed

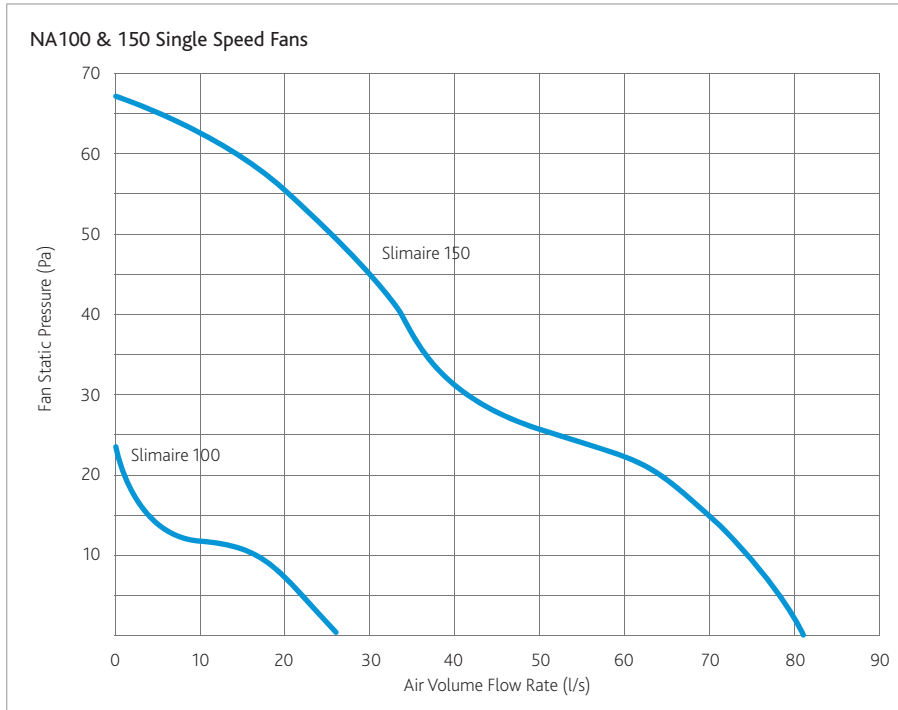

AVAILABLE NOW FROM
i-sells.co.uk

Unit 6 Chiltonian
203 Manor Lane
Lee, London
SE12 0TX

SALES: 0208 463 9696
FAX: 08456 44 60 02
EMAIL: sales@i-sells.co.uk
WEB: <http://www.i-sells.co.uk>



Control Function

Code	dBa @3m	Operating voltage	Control function
NA100/150	40/49	230	Standard version operated by remote switch.
NA100PC/150PC	40/49	230	Standard version operated by pull cord.
NA100T/150T	40/49	230	With integral overrun timer - the fan should be operated by a remote switch which can also serve to switch the room light on and off. After the light is switched off, the fan will continue to operate for a minimum of 3 minutes (adjustable to a maximum of 25 minutes) by turning the trimmer in a clockwise direction.
NA100HT/150HT	40/49	230	With integral humidistat and overrun timer - the adjustable, electronic humidistat is pre-set so that the fan will operate automatically when the moisture content in the room reaches a pre-set level of relative humidity. The fan will continue to run until the relative humidity falls below the pre-set level. This level can be adjusted by turning the trimmer on the fan. This fan can be operated by a remote switch or light switch allowing operation of the fan independently of the humidistat. The overrun timer, which will always make the fan continue to operate for the pre-set length of time even after it has been manually switched off, can be adjusted as described above.
NA100PIR/150PIR	40/49	230	With integral sensor and overrun timer - the fan will start to operate automatically when it detects the presence of a person. After the room is vacated, the fan will continue to operate for a minimum of 3 minutes (adjustable to a maximum of 25 minutes) by turning the trimmer in an anti-clockwise direction.
NA100-12	40	12	This version must be installed using the remote transformer supplied (see current IEE Regulations for guidance).
NA100T-12	40	12	With integral overrun timer adjusted as above. This version must be installed using the remote transformer supplied (see current IEE Regulations for guidance).

General Arrangement - Single Speed

DIMENSIONS (MM) & UNIT WEIGHT

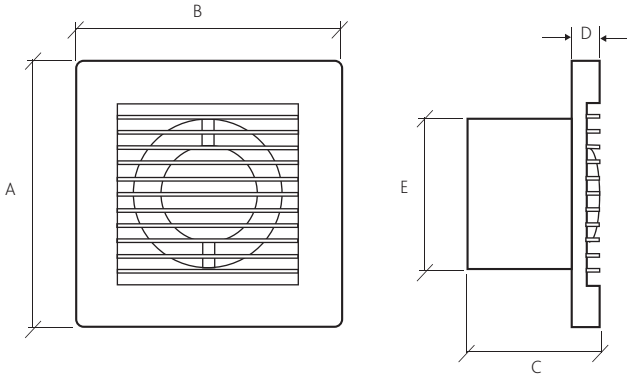

Unit	A	B	C	D	E dia.	Weight (Kg)
NA100	160	160	81	17	97	0.5
NA150	200	200	119	22	149	1.5

Wiring

NA100/150
with remote switch

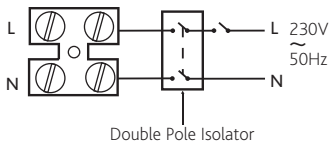

NA100PC/150PC
with pullcord

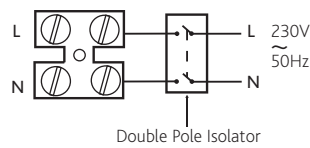

NA100T/150T
via light switch (or remote switch)

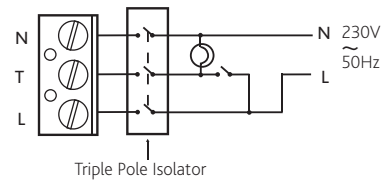

NA100/150HT PIR
with Humidistat and
Integral sensor.

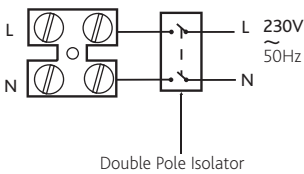

NA100-12, 12V
Must be installed with remote
transformer.

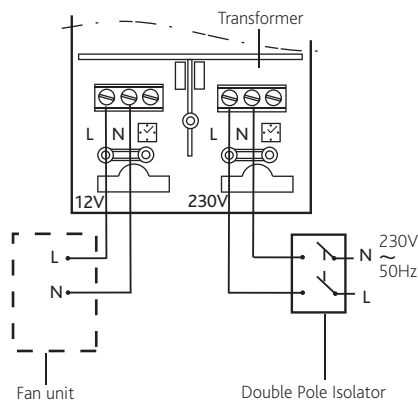

NA100T-12, 12V
via light switch (or remote switch)
Must be installed with remote transformer

