



The *Q-Aire* Range

HIGHEST
INDOOR
AIR QUALITY
IN NEW
HOMES



Innovation at its best

Since our inception in 1966, we have pioneered a number of new ventilation strategies and products now widely adopted by the industry, from the development of the Twin Fan to the invention of Positive Input Ventilation.

Today we remain at the forefront of domestic ventilation technology, with a range of products that solve the challenges faced by house builders and developers. From meeting building regulations to meeting short lead times, we deliver on product, price and service.

Nuaire is committed to the principles of energy-reduction, heat recovery and renewable product innovation. We continue to lead the industry in developing best practice and helping clients reduce their energy demands and carbon emissions.

Our committed staff include leading experts who are constantly setting new standards for the industry by developing new, innovative products which are rigorously tested in our multi-million pound test facilities; considered to be amongst the most modern and comprehensive in the world.



1st

OUR REPUTATION IS BASED ON PROVEN ACHIEVEMENTS

- 1st to introduce the Positive Input Ventilation strategy
- 1st to develop MVHR and MEV systems
- 1st to offer REVIT compatible BIM files
- 1st to provide a free design service to customers
- 1st to offer Double size carbon filter

Q-Aire

Quick Quiet Quality

The Nuair **Q-Aire range** of products has been designed to complement ventilation systems that are a necessity in modern living. We recognise that customers need products **quickly**, systems that work **quietly** and confidence in their high **quality** - something that comes as standard with Nuair. The range is comprised of a supply and extract valve, an in-line carbon filter, an acoustic enclosure for an MVHR unit only and finally a unique all-in-one acoustic enclosure surrounding not only an MVHR unit but a built in silencer as well.

As Mechanical Ventilation Heat Recovery fast becomes the most popular form of ventilation, Nuair continue to lead the way in innovation and market leadership. The introduction of the Q-Aire range means Nuair can offer an entire MVHR solution for new build properties, with every aspect of the system taken care of.

The Q-Aire range of products benefits everybody from consultants to installers because of the improvements they make to both the commissioning and performance of an MVHR system. Choose from the only valve on the market which offers both a built in humidistat and G2 filter, a carbon filter with Colourcell™ technology and two acoustic solutions which not only offer a significant reduction in noise output, but also aesthetically pleasing enclosures.



Q-Aire Acoustic Enclosure



Q-Aire 1Z



Q-Aire Supply and Extract Valve



Q-Aire Carbon Filter

Q-Aire

V125 / EV125F / EV125FH

The Supply & Extract Valve can help solve common problems with MVHR commissioning, balancing and performance. It is available in three versions: standard supply and extract (Q-Aire-V125), filtered extract (Q-Aire-EV125F) or filtered extract with integral humidistat (Q-Aire-EV125FH). Q-Aire Supply & Extract Valve is the only lockable, filtered valve on the market and is fully-compliant with the latest NHBC guidance.

The filtered extract version removes the need for a ducting cleaning regime and access panels because air is filtered before it enters the ducting. The valve is lockable once commissioned and even when the filter is removed and changed, once replaced it returns to the commissioned position. The Supply valve is fully lockable and features a deflector plate so even if positioned in a corner, or next to a wall, it is able to deflect air evenly across the room.

Features & Benefits

- Only filtered extract with built in humidistat
- Same valve for supply and extract
- Lockable position for commissioning
- Easy maintenance.



Q-AIRE-V125
Supply & Extract Valve



This in-built humidity sensor simply uses the Ecosmart SELV cable to connect back to the MVHR or MEV unit.



Q-AIRE-EV125F
Extract Valve with filter



Q-AIRE-EV125FH
Extract Valve with filter and fitted integral humidistat



The filter can be quickly replaced by simply removing the damper assembly and changing the filter. The damper assembly is then put back into its place without any adjustment of the commissioned set point, thus ensuring the system remains commissioned.

Air Resistance Performance

	Resistance in Pa				
	@8l/s	@13l/s	@21l/s	@29l/s	@37l/s
Existing V125S - 10mm Gap (CATALOGUE VALUES)	6	10	19	35	55
Q-AIRE-V125 (13mm Gap - Extract)	2	6	14	26	41
Q-AIRE-V125 (13mm Gap - Supply)	2	4	11	20	33
Q-AIRE-EV125F (13mm Gap - Extract)	4	11	27	48	73
Q-AIRE-EV125FH (13mm Gap - Extract)	4	11	27	48	73

Consultants Specification

OPERATION

The supply and extract valves are used to control and distribute airflow entering or being removed from a dwelling. They shall be capable of being used on their own, with a filter or with a filter and integral humidistat control.

UNIT SPECIFICATION

Each valve shall be low profile, protruding from the ceiling by no more than 18mm when closed.

Each valve will be suitable for 125mm diameter ducting.

Each valve shall be made from flame retardant ABS plastic.

There shall be a means of adjusting the opening aperture for commissioning purpose with a decorative panel supplied to hide the commissioning screw.

The flow deflector shall be spring loaded to prevent vibration.

It shall be possible to remove/replace the bezel disc assembly within the bezel for filter access without altering the commissioned position of the valve or deflector.

Filter shall be easily removed and be of G2 grade.

The assembly shall be supplied with a deflector plate to enable air to be directed away from obstacles or to prevent air being blown in a direction which would create nuisance draughts.

An optional humidity PCB for connection to ventilation unit shall be available with set point accessible on bezel disc removal.

Humidistat PCB shall be Nuaire Ecosmart compatible.

The valve shall be offered with a 5 year warranty.

The manufacturer's recommendations should be observed at all times.

The valve shall be manufactured by Nuaire.

OPTIONS

Three options shall be available:

- Q-AIRE-V-125 Supply & Extract Valve
- Q-AIRE-EV125F Extract Valve with filter
- Q-AIRE-EV125FH Extract Valve with filter and fitted with integral humidistat

Q-Aire IAQ-BOX

With concerns over rising air pollution, Indoor Air Quality (IAQ) has quickly become a serious subject for the building industry. As such an Air Quality report must now be produced at planning stage making this issue one that cannot be ignored.

Nuaire's IAQ-BOX range offers solutions for urban areas where air pollutants such as NO₂, Carbon Dioxide and other dangerous Particulate Matter need to be filtered before outdoor air enter the property. These specifiable products will refine traditional filtration and ensure that Air Quality planning obligations are met.

Features & Benefits

- 99.5% NO₂ filtration- Highest on the market
- Lowest resistance, meaning MVHR systems are not affected
- Low profile design for flexible installation
- Unique single cell carbon filter
- Innovative Double size unit with multi-spigot option
- Choice of pre-filters for increased Particulate Matter filtration



The IAQ-V125 is Nuaire's unique carbon filter supply valve



IAQBOX-S



IAQBOX-D

IAQBOX-S

The IAQBOX-S offers a unique approach in carbon filtration by using a single cell carbon filter to refine polluted outdoor air that MVHR systems bring in to properties.

There is a choice of PM2.5 or PM10 pre-filters to further enhance the filtration of polluted, outdoor air when it enters the property. To specify the IAQBOX-S with fitted pre-filters please choose from the following codes.



	IAQBOX-S	IAQBOX-S-PM10	IAQBOX-S-PM2.5
NO PRE-FILTER			
PM10 PRE-FILTER			
PM2.5 PRE-FILTER			

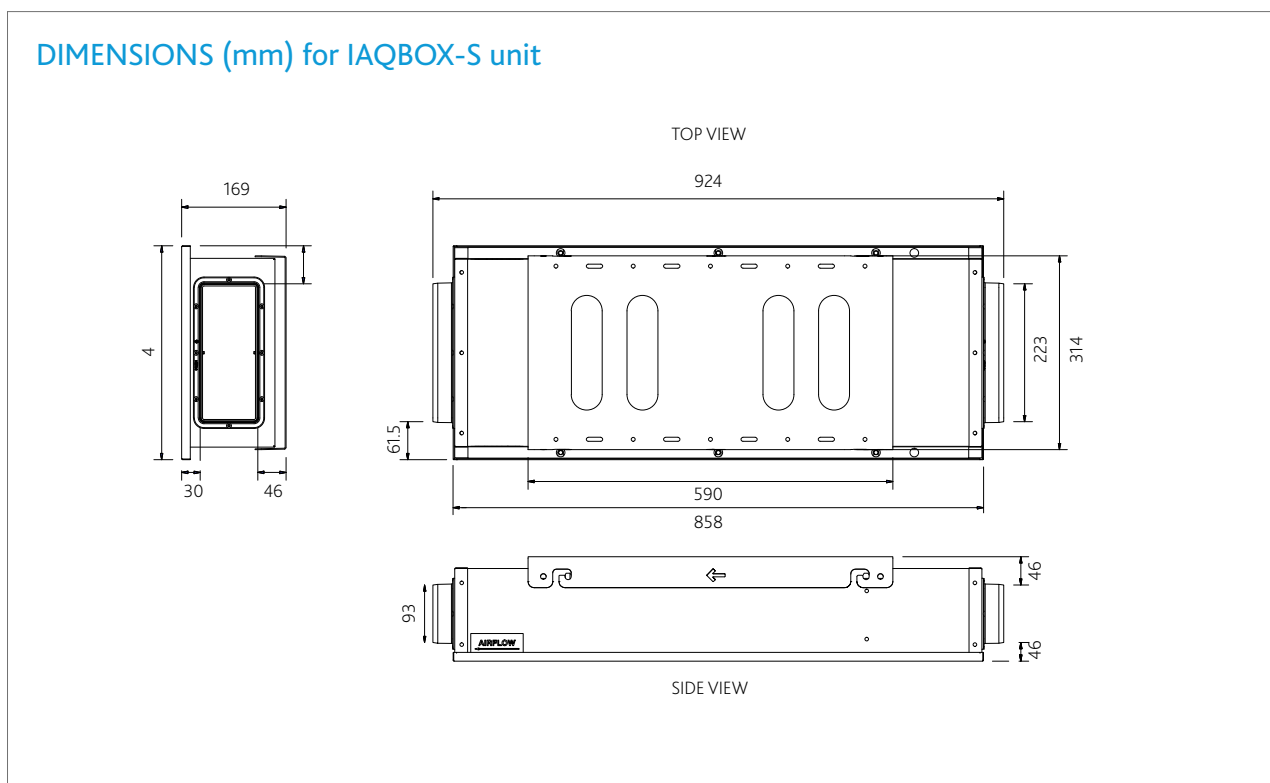
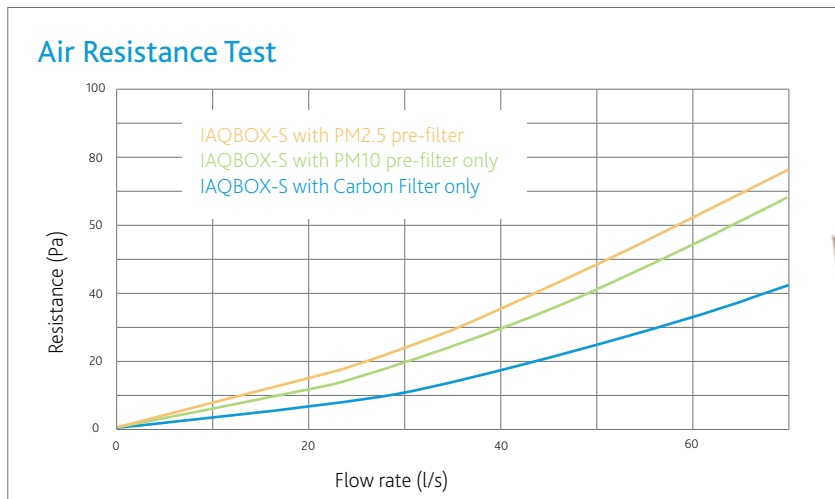
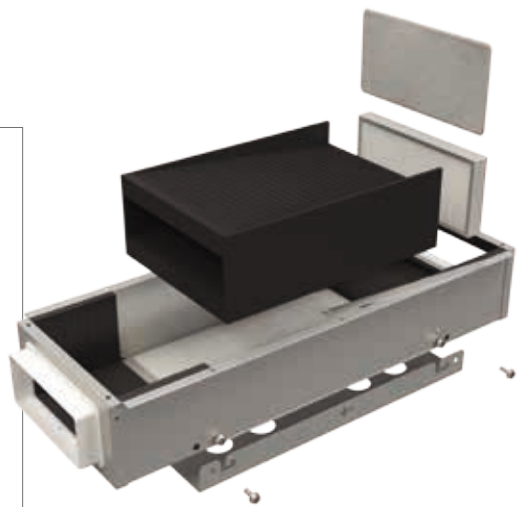

IAQBOX-D

The IAQBOX-D is Nuair's unique offering, showcasing a Double size unit which allows a larger volume of air flow to pass through the carbon filter resulting in some of the lowest resistances on the market. This unit also comes with the option of 2 outlet spigots, further reducing system pressure and resistance by decreasing the number of duct runs needed to feed to all supply rooms.

There is a choice of PM2.5 or PM10 pre-filters to further enhance the filtration of polluted, outdoor air when it enters the property. To specify this unique carbon filter with fitted pre-filters please choose from the following codes.



	IAQBOX-D	IAQBOX-D-PM10	IAQBOX-D-PM2.5
NO PRE-FILTER			
PM10 PRE-FILTER			
PM2.5 PRE-FILTER			

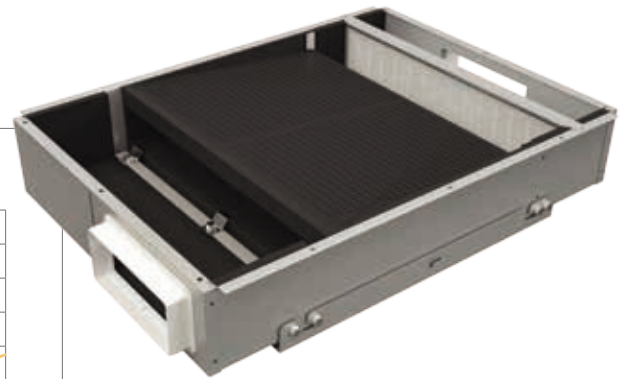

Air Resistance Test

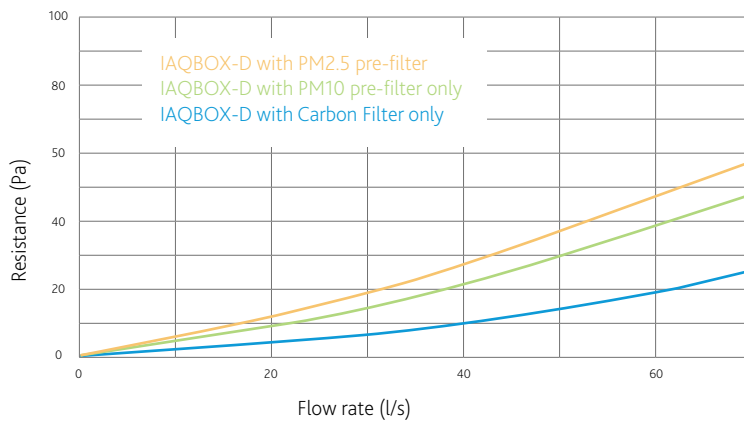

DIMENSIONS (mm) for IAQBOX-D unit

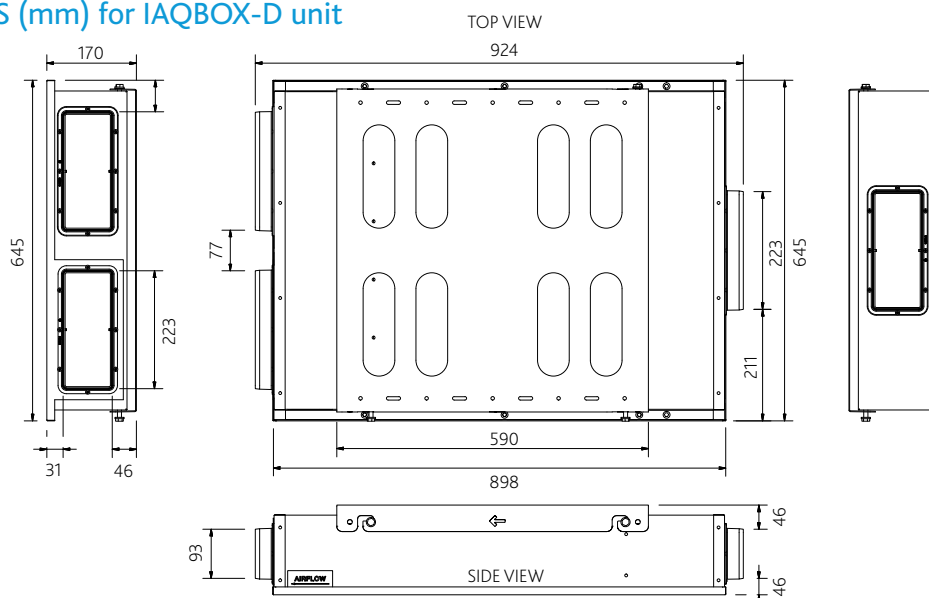

Consultants Specification

UNIT SPECIFICATION

The IAQBOX-S and IAQBOX-D (plus pre-filter variant codes) comprise the Q-Aire IAQBOX range and shall be manufactured in galvanised sheet metal, with an integral foam lining to reduce noise & provide internal sealing. Each inline filter shall have the ability to have an optional PM10 or PM2.5 pre-filter inserted into the filter box to be capable of additional particulate filtration; particularly from diesel vehicle fumes.

The IAQBOX shall come complete with a removable mounting bracket.

The double size IAQBOX-D range of units have the option to be configured using a single or double spigot on the outlet. Double spigot on the outlet shall provide lower air resistance and further ducting options.

The IAQBOX shall come complete with a single of plastic construction, containing two 30mm (approx.) beds of activated carbon pellets providing a large surface to filter the airflow. The filters shall be easily removed and replaced when required. The filter shall have a minimum efficiency of between 96% and 99.5% effectiveness in the removal of Nitrogen Oxides/Dioxides.

The unit efficiency shall be confirmed and independently verified by a BRE (Building Research Establishment) test method and the information shall be provided by the filter manufacturer for approval.

The activated carbon shall have at least the following minimum qualities:

Bulk density	kg/m ³	480 (+/-5%)
Nominal diameter of cylindrical pellets	mm	4.0
Nominal length of cylindrical pellets	mm	8.0
Moisture content (approx.)	%	3
Crush strength (minimum)	kg	2
Removal capacity for Cl ₂ of own weight	%	10
Minimum design efficiency	%	99.5
Typical air velocity	m/s	0.3 - 2.5
Suitable for relative air humidities	%	10 - 95
Temperature range	°C	-20 - +51

The unit shall be suitable for 220x90mm ducting.

The unit shall be installed in conjunction with the manufacturer's installation and maintenance guidelines.

The unit shall be offered with a 5 year warranty; 1 year parts and labour, remaining years parts only. This warranty is void if the equipment is modified without authorisation, is incorrectly applied, misused, disassembled or not installed, commissioned and maintained in accordance with the details contained in the I&M manual and general good practice.

Acoustic solution for MRXBOX95(AB)-WH1 and MRXBOX95(AB)-WM2

Nuaire's First Fix and Acoustic Solution are designed to not only reduce noise but to improve the installation when wall or cupboard mounting the MRXBOX95(AB)-WH1 and MRXBOX95(AB)-WM2 Units.

Offering the only complete MVHR acoustic and first fix solution to overcome both noise and ease the installation of heat recovery units. Nuaire's solution addresses both duct and breakout noise, provides an aesthetically pleasing cupboard installation for the home occupant and reduces installation errors and time.

These units are also available in Opposite Handed format.



Typical Installation

FIRST FIX SOLUTION FF-WH1/FF-WM2

Nuaire's First Fix box is fixed to the underside of the floor slab at first fix stage of the build. The box has four airflow chambers with optional positions for 204x60mm spigots. Ceilings can then be boarded within the cupboard space easily and quickly without the risk of the spigots not aligning to the fan unit.

MRXBOX-FF-WH1

SILENCER SIL-WH1/SIL-WM2

Nuaire has created a unique solution that is not only designed to reduce noise significantly, addressing duct and breakout noise, but is visibly appealing for the home occupant. It can be used with or without the First Fix Solution.

MRXBOX95(AB)-WH1/ MRXBOX95(AB)- WM2

Nuaire's Silencer and First Fix solution are compatible with the MRXBOX95(AB)-WH1 and MRXBOX95(AB)-WM2 heat recovery units, which are designed for medium to large properties.

Acoustic data for MRXBOX95(AB)-WH1 with Silencer and/or First Fix

WH1 with SIL Sound Data		Frequency/Hz	63	125	250	500	1K	2K	4K	8K	dB(A) @3m
Curve	Max. Power/W	Sound power levels dB re 1pW									
1	150	Open Inlet	40	41	49	39	25	<16	<16	<16	37
		Open Outlet	45	53	58	53	39	34	30	26	
		Breakout	56	61	59	53	43	40	25	16	

WH1 with FF Sound Data		Frequency/Hz	63	125	250	500	1K	2K	4K	8K	dB(A) @3m
Curve	Max. Power/W	Sound power levels dB re 1pW									
1	150	Open Inlet	44	44	53	43	40	32	19	<16	37
		Open Outlet	48	58	63	60	55	53	44	35	
		Breakout	56	61	59	53	43	40	25	16	

WH1 with FF & SIL Sound Data		Frequency/Hz	63	125	250	500	1K	2K	4K	8K	dB(A) @3m
Curve	Max. Power/W	Sound power levels dB re 1pW									
1	150	Open Inlet	36	31	43	33	25	<16	<16	<16	37
		Open Outlet	38	45	49	42	32	25	22	<16	
		Breakout	56	61	59	53	43	40	25	16	

The breakout case-radiated dBA values are given for Hemispherical free field radiation at 3m – to obtain the spherical radiated data, subtract 3dBA.

Silencer Corrections

SIL Corrections	Open Inlet	63	125	250	500	1K	2K	4K	8K
	Open Inlet	-8	-10	-9	-10	-22	-24	-16	-13
	Open Outlet	-11	-10	-9	-14	-23	-26	-20	-15
	Breakout	0	0	0	0	0	0	0	0

FF Corrections	Open Inlet	63	125	250	500	1K	2K	4K	8K
	Open Inlet	-4	-7	-5	-6	-7	-7	-6	-4
	Open Outlet	-8	-5	-4	-7	-7	-7	-6	-6
	Breakout	0	0	0	0	0	0	0	0

FF+SIL Corrections	Open Inlet	63	125	250	500	1K	2K	4K	8K
	Open Inlet	-12	-20	-15	-16	-22	-24	-19	-16
	Open Outlet	-18	-18	-18	-25	-30	-35	-28	-26
	Breakout	0	0	0	0	0	0	0	0

Technical

DIMENSIONS (mm) for WH1 unit

SIL-WH1

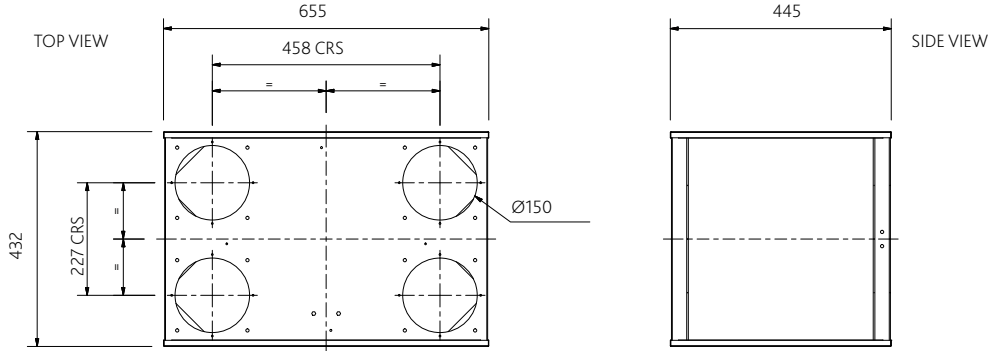

FF-WH1

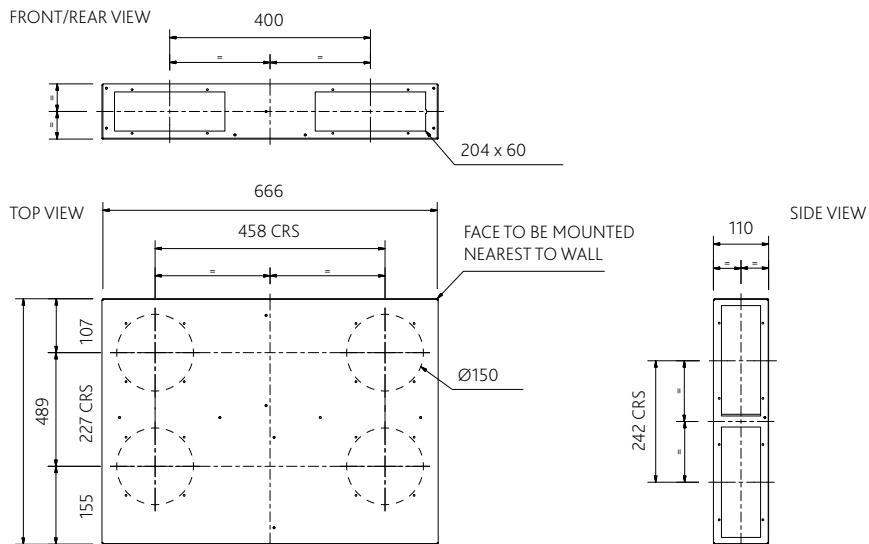

COMPLETED SYSTEM

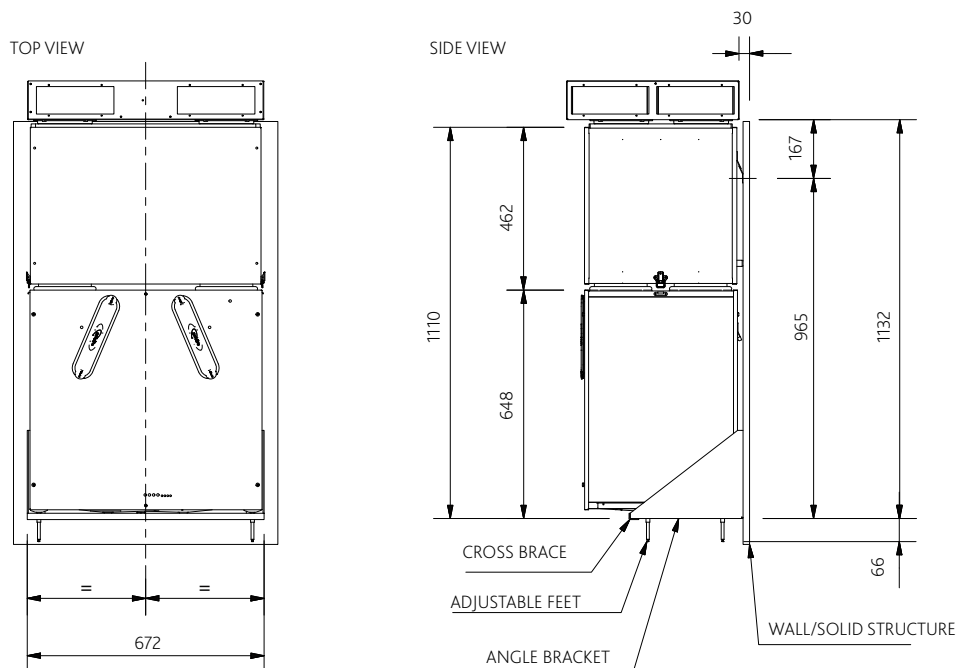

Consultants Specification

SIL-WH1

The unit offers the facility to be fitted directly to the MVHR unit and plenum chamber without the need for spigots reducing breakout noise. However, there is the capability to fit 150mm circular spigots as an alternative option.

The unit shall be fully lined with acoustic material offering excellent noise reduction.

Wall mounting brackets are to be supplied as part of the system to allow the MVHR unit to be raised after other system components are installed to form an airtight seal and enable the installation to be levelled.

The unit shall be clamped to the MRXBOX95(AB)-WH1 unit to provide an efficient seal and ensure correct alignment.

The unit shall be fixed in position during installation as a standalone section without relying on other system elements.

FF- WH1

The unit shall be supplied with 204mm x 60mm rectangular spigots to connect to the duct run, with the ability to be fitted in eight separate positions reducing the requirement for bends in the system.

The unit offers the facility to be fitted directly to the mating sections without the need for spigots reducing breakout noise, additional 150mm circular spigots to be supplied as an alternative option.

TECHNICAL DATA

Units shall be one of MRXBOX95AB-WH1, MRXBOX95-WH1, MRXBOX95AB-WH1-OH, MRXBOX95-WH1-OH as manufactured by Nuaire.

SPECIFICATION

The unit shall be fully insulated providing excellent thermal and acoustic characteristics and shall be complete with a multi plate counter flow high efficiency heat exchanger block, with a thermal efficiency of up to 95%. The heat exchanger shall be protected by G3 grade filters on fresh air inlet and system extract. The heat exchanger and filters shall be accessible via the front access panel, enabling quick and easy maintenance.

The unit shall have low energy, high efficiency EC fan/motor assemblies with sealed for life bearings, the impellers shall be backward curved centrifugal type. The motors shall be suitable of an ambient temperature of 40°C.

The unit shall be supplied complete with a condensate drip tray and 21.5mm drain connection.

The unit shall be suitable for 150mm diameter circular ducting.

The breakout noise level and power requirements shall be as detailed by the unit manufacturer and in accordance with the ventilation equipment schedule.

The unit shall be offered with a 5 year warranty.

OPERATION

The supply and extract ventilation unit shall be positioned as indicated on the drawings and shall be in accordance with the particular fan schedule in the specification. This unit is also available in Opposite Hand formatting.

The combined supply and extract with heat recovery unit, shall supply filtered fresh air to each of the habitable rooms and vitiated air shall be extracted from the wet areas e.g. bathroom, en-suite, w.c, kitchen, utility rooms, etc. The supply air shall be pre-heated by the warm extract air via the integrated counter-flow heat exchanger element. The extracted air shall also be filtered before it reaches the heat exchanger block.

The ventilation unit shall vary its speed and therefore the ventilation rate, as it receives signals from the switched live signal from light/ remote switches or any ancillary sensors. When signals are received, the fan shall alter its speed to adjustable, normal and boost rates.

The unit shall have the facility to commission the supply and extract fans independently on minimum speed (continuous background ventilation), and boost speed, via inbuilt minimum and maximum speed adjustment. The fans shall have infinitely variable speed control.

INTEGRAL AUTOMATIC SUMMER BYPASS (MRXBOX95AB-WH1 & MRXBOX95AB-WH1-OH only)

Including Automatic SUMMER BYPASS where intake and return air temperatures shall be measured so that supply air temperatures can be maximised during winter months and minimised as external ambient temperature rises. The Summer Bypass damper shall be opened by a wax actuator. Supply and Extract air shall be filtered irrespective of the bypass setting (open or closed).

CONTROL OPTIONS

All versions shall have the following functions integrally mounted within the fan unit on a purpose made PCB, all such components pre-wired and factory fitted by the manufacturer:

- Independent control of background supply and extract flow rates
- Independent control of boost speed supply and extract flow rates
- Integral fan failure indication
- Integral S/L terminal for boost from remote switch, e.g. light switch, kitchen boost switch
- Integral heat exchanger frost protection
- Discreet daily run monitor.
- Integral humidistat.

OPTIONAL CONTROLS

MRXBOX95-RFI Remote fail indicator.

MRXBOX95-PIR (Passive Infra-Red) A low voltage sensor which detects movement and activates system.

MRXBOX95-HUM A low voltage sensor which activates the system when the relative humidity level is above a set point.

MRXBOX-VSC An LCD controller for MVHR system with a 3.2" touch screen display.

Acoustic data for MRXBOX95(AB)-WM2 with Silencer and/or First Fix

WM2 with SIL Sound Data		Frequency/Hz	63	125	250	500	1K	2K	4K	8K	dBA @3m
Curve	Max. Power/W	Sound power levels dB re 1pW									
1	150	Open Inlet	49	47	52	46	28	23	20	21	37
		Open Outlet	44	55	62	53	41	34	31	28	
		Breakout	61	61	56	53	47	44	35	33	

WM2 with FF Sound Data		Frequency/Hz	63	125	250	500	1K	2K	4K	8K	dBA @3m
Curve	Max. Power/W	Sound power levels dB re 1pW									
1	150	Open Inlet	53	50	56	50	43	40	30	30	37
		Open Outlet	47	60	67	60	57	53	45	37	
		Breakout	61	61	56	53	47	44	35	33	

WM2 with FF & SIL Sound Data		Frequency/Hz	63	125	250	500	1K	2K	4K	8K	dBA @3m
Curve	Max. Power/W	Sound power levels dB re 1pW									
1	150	Open Inlet	45	37	46	40	28	<16	<16	<16	37
		Open Outlet	37	47	53	42	34	25	23	17	
		Breakout	61	61		53	47	44	35	33	

The breakout case-radiated dBA values are given for Hemispherical free field radiation at 3m – to obtain the spherical radiated data, subtract 3dBA.

Silencer Corrections

SIL Corrections	Open Inlet	63	125	250	500	1K	2K	4K	8K
	Open Inlet	-8	-10	-9	-10	-22	-24	-16	-13
	Open Outlet	-11	-10	-9	-14	-23	-26	-20	-15
	Breakout	0	0	0	0	0	0	0	0

FF Corrections	Open Inlet	63	125	250	500	1K	2K	4K	8K
	Open Inlet	-4	-7	-5	-6	-7	-7	-6	-4
	Open Outlet	-8	-5	-4	-7	-7	-7	-6	-6
	Breakout	0	0	0	0	0	0	0	0

FF+SIL Corrections	Open Inlet	63	125	250	500	1K	2K	4K	8K
	Open Inlet	-12	-20	-15	-16	-22	-24	-19	-16
	Open Outlet	-18	-18	-18	-25	-30	-35	-28	-26
	Breakout	0	0	0	0	0	0	0	0

Technical

DIMENSIONS (mm) for WM2 unit

SIL-WM2

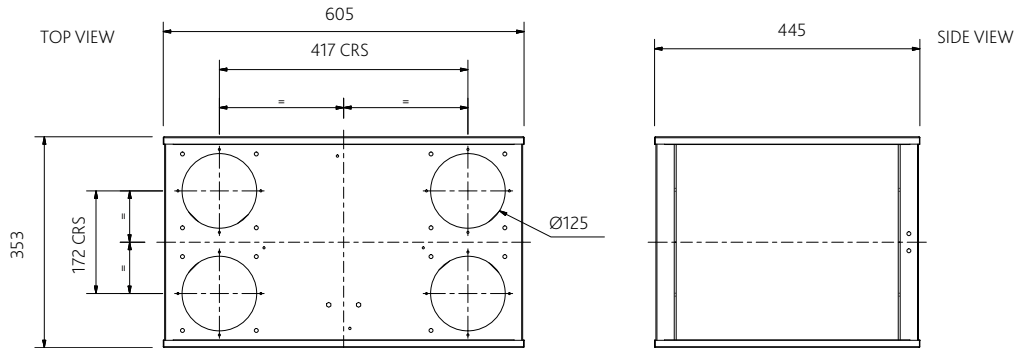

FF-WM2

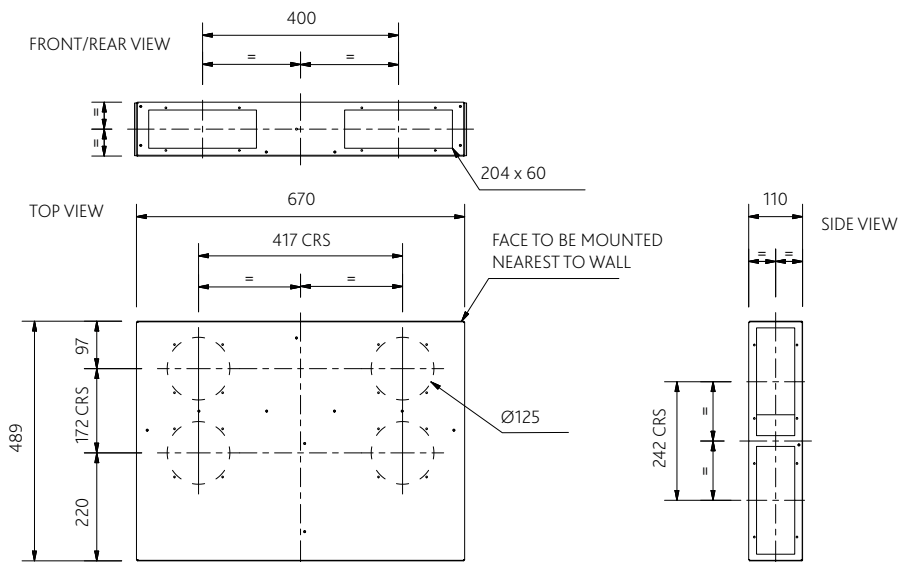

COMPLETED SYSTEM

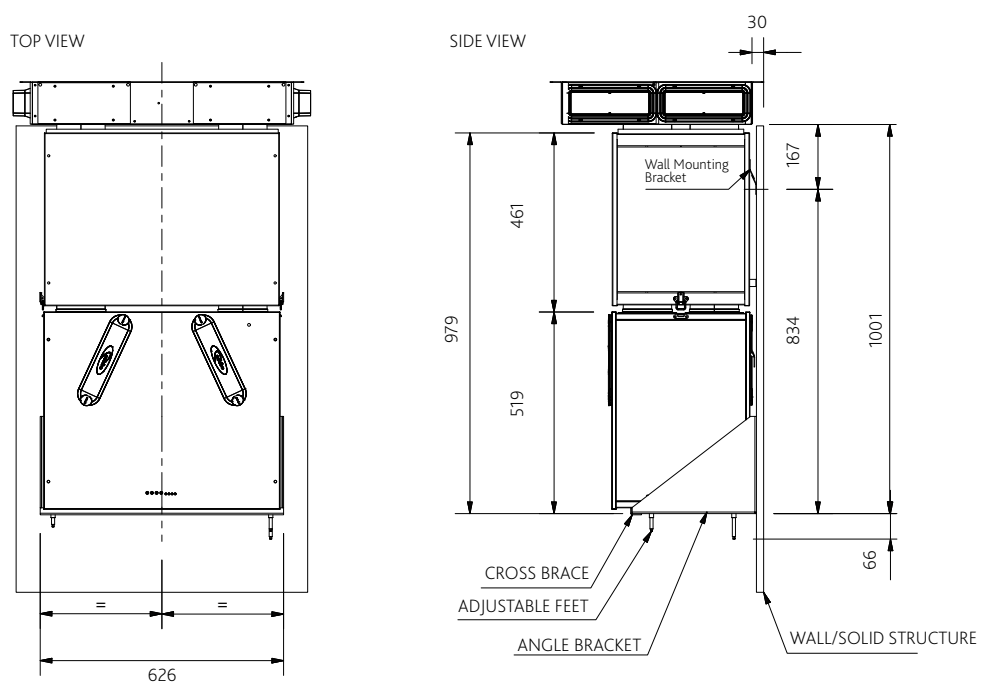

Consultants Specification

SIL- WM2

The unit offers the facility to be fitted directly to the MVHR unit and plenum chamber without the need for spigots reducing breakout noise. However, there is the capability to fit 125mm circular spigots as an alternative option.

The unit shall be fully lined with acoustic material offering excellent noise reduction.

Wall mounting brackets are to be supplied as part of the system to allow the MVHR unit to be raised after other system components are installed to form an airtight seal and enable the installation to be levelled.

The unit shall be clamped to the MRXBOX95(AB)-WM2 unit to provide an efficient seal and ensure correct alignment.

The unit shall be fixed in position during installation as a standalone section without relying on other system elements.

FF-WM2

The unit shall be supplied with 204mm x 60mm rectangular spigots to connect to the duct run, with the ability to be fitted in eight separate positions reducing the requirement for bends in the system.

The unit offers the facility to be fitted directly to the mating sections without the need for spigots reducing breakout noise, additional 125mm circular spigots to be supplied as an alternative option.

TECHNICAL DATA

Units shall be one of MRXBOX95AB-WM2, MRXBOX95-WM2, MRXBOX95AB-WM2-OH, MRXBOX95-WM2-OH as manufactured by Nuaire.

SPECIFICATION

The unit shall be fully insulated providing excellent thermal and acoustic characteristics and shall be complete with a multi plate counter flow high efficiency heat exchanger block, with a thermal efficiency of up to 95%. The heat exchanger shall be protected by G3 grade filters on fresh air inlet and system extract. The heat exchanger and filters shall be accessible via the front access panel, enabling quick and easy maintenance.

The unit shall have low energy, high efficiency EC fan/motor assemblies with sealed for life bearings, the impellers shall be backward curved centrifugal type. The motors shall be suitable of an ambient temperature of 40°C.

The unit shall be supplied complete with a condensate drip tray and 21.5mm drain connection.

The unit shall be suitable for 125mm diameter circular ducting.

The breakout noise level and power requirements shall be as detailed by the unit manufacturer and in accordance with the ventilation equipment schedule.

The unit shall be offered with a 5 year warranty.

OPERATION

The supply and extract ventilation unit shall be positioned as indicated on the drawings and shall be in accordance with the particular fan schedule in the specification. This unit is also available in Opposite Hand formatting.

The combined supply and extract with heat recovery unit, shall supply filtered fresh air to each of the habitable rooms and vitiated air shall be extracted from the wet areas e.g. bathroom, en-suite, w.c, kitchen, utility rooms, etc. The supply air shall be pre-heated by the warm extract air via the integrated counter-flow heat exchanger element. The extracted air shall also be filtered before it reaches the heat exchanger block.

The ventilation unit shall vary its speed and therefore the ventilation rate, as it receives signals from the switched live signal from light/ remote switches or any ancillary sensors. When signals are received, the fan shall alter its speed to adjustable, normal and boost rates.

The unit shall have the facility to commission the supply and extract fans independently on minimum speed (continuous background ventilation), and boost speed, via inbuilt minimum and maximum speed adjustment. The fans shall have infinitely variable speed control.

INTEGRAL AUTOMATIC SUMMER BYPASS (MRXBOX95AB-WM2 & MRXBOX95AB-WM2-OH only)

Including Automatic SUMMER BYPASS where intake and return air temperatures shall be measured so that supply air temperatures can be maximised during winter months and minimised as external ambient temperature rises. The Summer Bypass damper shall be opened by a wax actuator. Supply and Extract air shall be filtered irrespective of the bypass setting (open or closed).

CONTROL OPTIONS

All versions shall have the following functions integrally mounted within the fan unit on a purpose made PCB, all such components pre-wired and factory fitted by the manufacturer:

- Independent control of background supply and extract flow rates
- Independent control of boost speed supply and extract flow rates
- Integral fan failure indication
- Integral S/L terminal for boost from remote switch, e.g. light switch, kitchen boost switch
- Integral heat exchanger frost protection
- Discreet daily run monitor.
- Integral humidistat.

OPTIONAL CONTROLS

MRXBOX95-RFI Remote fail indicator.

MRXBOX95-PIR (Passive Infra-Red) A low voltage sensor which detects movement and activates system.

MRXBOX95-HUM A low voltage sensor which activates the system when the relative humidity level is above a set point.

MRXBOX-VSC An LCD controller for MVHR system with a 3.2" touch screen display.

MRXBOX95-WM2-AE & MRXBOX95AB-WM2-AE

Both the MRXBOX95-WM2-AE and MRXBOX95AB-WM2-AE are designed to provide optimised balanced (supply and extract) mechanical ventilation heat recovery, all whilst being encased within our latest Acoustic Enclosure.

Tempered air is delivered into 'living areas' whilst extracting moisture laden air from 'wet' areas, creating comfortable and well ventilated homes. The unit has the facility to commission the supply and extract fans independently on both minimum and maximum speeds, and the heat exchange block can recover up to 95% of the normally wasted heat that has been extracted from 'wet rooms'. The "AE" element of the above product code relates to our new Q-Aire Acoustic Enclosure, designed specifically for our MRXBOX range of heat recovery units. This new unit incorporates an acoustic surrounding to your MVHR unit and flexible duct connectors, significantly decreasing noise and vibration output.

Please note both of these units are available in Opposite Handed format. EU energy ratings A+ and A respectively as per EU regulation No.1254/2014. Please contact our Sales Team for further details.



Typical Installation



Limited ceiling voids in modern apartments and complex duct arrangements coupled with increased airflow demands placed on MVHR systems in an effort to reduce the risk of overheating lead to higher system resistances and running speeds.

Restrictions on utility cupboard space, practical and financial limitations frequently prevent the construction of acoustic cupboards, whilst modern light-weight wall construction methods offer little mass to absorb unit noise and vibration. This can often result in the transfer of low frequency noise and vibration into adjacent living and sleeping areas.

These factors leave designers at risk of exceeding the stringent noise requirements specified in Part F of the building regulations and further defined by CIBSE.

By integrating the MVHR unit and flexible connections within an enclosure and supporting the internals on anti-vibration mounts, noise and vibration are isolated.

Performance - MRBOX95(AB)-WM2-AE

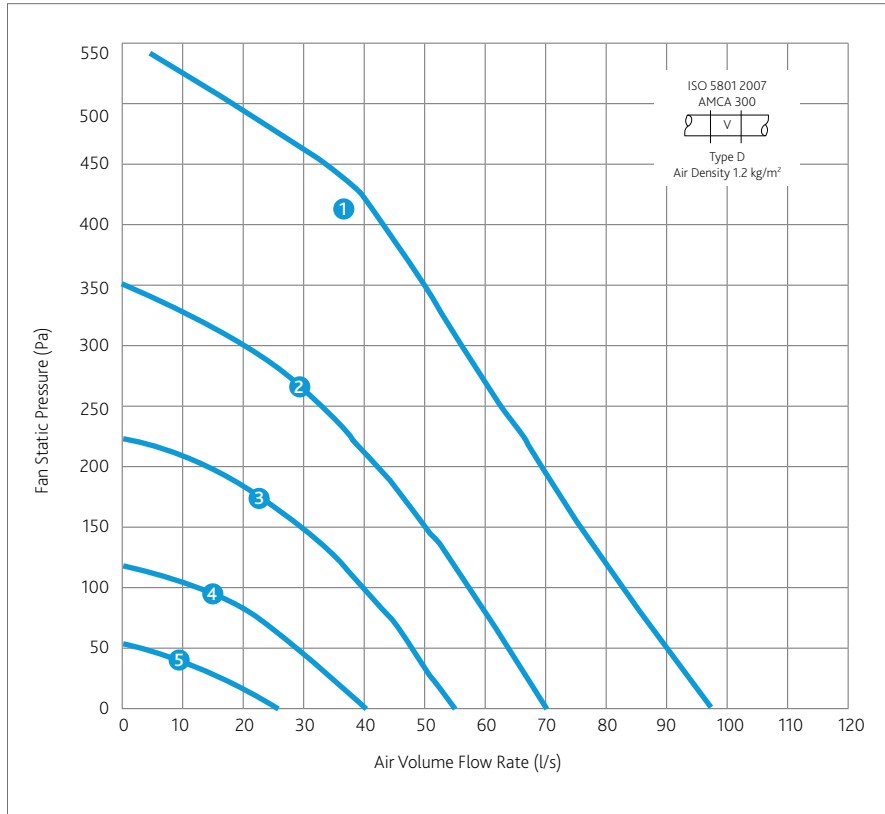

CODE DESCRIPTION

MRXBOX95-WM2-AE

1 2 3 4 5 6

1. Multi-room supply and extract heat recovery
2. Product range
3. Efficiency
4. Wall/cupboard application
5. High Duty Model 1
6. Acoustic enclosure of MVHR unit

MRXBOX95AB-WM2-AE

1 2 3 4 5 6 7

1. Multi-room supply and extract heat recovery
2. Product range
3. Efficiency
4. Automatic Summer Bypass
5. Wall/cupboard application
6. High Duty Model 1
7. Acoustic enclosure of MVHR unit

Electrical & Sound

WM2 Sound Data with AE fitted											
	Maximum power consumption	Frequency/Hz	63	125	250	500	1K	2K	4K	8K	dBA @3m
Curve	W	Sound Power Levels dB re 1pW									
1	150	Open Inlet	57	57	61	56	50	47	36	34	
		Open Outlet	55	65	71	67	64	60	51	43	
		Breakout	59	59	48	38	24	22	9	21	28
2	75	Open Inlet	51	51	55	48	40	35	25	20	
		Open Outlet	53	59	61	58	55	52	39	32	
		Breakout	54	53	43	29	<16	<16	<16	<16	22
3	36	Open Inlet	48	44	48	42	33	28	18	<16	
		Open Outlet	52	56	55	53	49	45	32	25	
		Breakout	50	52	39	24	<16	<16	<16	<16	20
4	14	Open Inlet	44	44	39	34	27	21	<16	<16	
		Open Outlet	51	52	49	48	43	37	25	18	
		Breakout	47	50	36	19	<16	<16	<16	<16	18
5	8	Open Inlet	40	39	25	22	18	<16	<16	<16	
		Open Outlet	50	48	41	41	36	24	17	<16	
		Breakout	44	48	31	<16	<16	<16	<16	<16	15
WM2 Sound Data with AE & DB fitted											dBA @3m
1	150	Open Inlet	57	50	56	51	43	38	30	26	
		Open Outlet	51	60	65	57	55	50	46	30	
		Breakout	59	59	48	38	24	22	9	21	28

The maximum power consumption shown above (Watts) is consumed on units running continuously, not taking into account any heat recovery saving and based on SAP Appendix Q testing. The breakout case-radiated dBA values are given for Hemispherical free field radiation at 3m – to obtain the spherical radiated data, subtract 3dBA.

Sap Appendix Q Test Results

Product Code	MRXBOX95AB-WM2-AE			MRXBOX95-WM2-AE		
SAP Identifier	MRXBOX95AB-WM2			MRXBOX95-WM2		
Application	Specific Fan Power (W/l/s)	Heat Exchange Efficiency	Energy Saving Trust Best Practice Compliant	Specific Fan Power (W/l/s)	Heat Exchange Efficiency	Energy Saving Trust Best Practice Compliant
Kitchen + 1 Wet Room	0.56	86%	Yes	0.56	87%	Yes
Kitchen + 2 Wet Room	0.66	85%	Yes	0.68	87%	Yes
Kitchen + 3 Wet Room	0.79	84%	Yes	0.85	86%	Yes
Kitchen + 4 Wet Room	1.02	83%	Yes	1.06	86%	Yes
Kitchen + 5 Wet Room	1.23	82%	Yes	-	-	Yes

General Arrangement

STANDARD UNIT SPIGOT LOCATION & DUCTING REFERENCES

- Spigot 1. 125mm dia. = Extract air from dwelling
- Spigot 2. 125mm dia. = Exhaust air to outside
- Spigot 3. 125mm dia. = Intake air from outside
- Spigot 4. 125mm dia. = Supply air to property

OPPOSITE HANDED UNIT SPIGOT LOCATION & DUCTING REFERENCES

- Spigot 1. 125mm dia. = Intake air from outside
- Spigot 2. 125mm dia. = Supply air to property
- Spigot 3. 125mm dia. = Extract air from dwelling
- Spigot 4. 125mm dia. = Exhaust air to outside

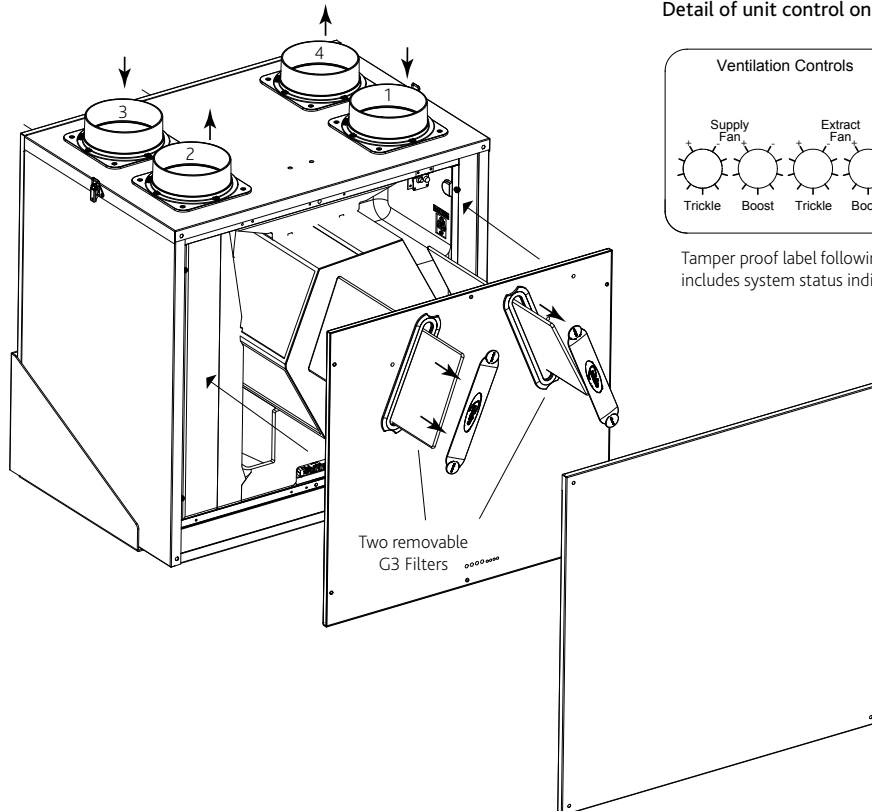

Detail of unit control on front panel.

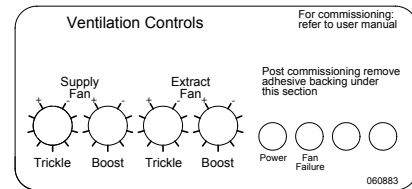

Tamper proof label following commissioning, includes system status indication.

Ancillaries

Distribution Box

The DB-WM2 is fitted on top of the MRXBOX95(AB)-WM2-AE before installation and offers a neat arrangement by directly distributing the initial ducting. It further benefits this MVHR system by reducing any in-line noise breakout, therefore improving this acoustic solution.

*For the DB-WM2 acoustic data please refer to the bottom 3 lines of the table found on pg 18.

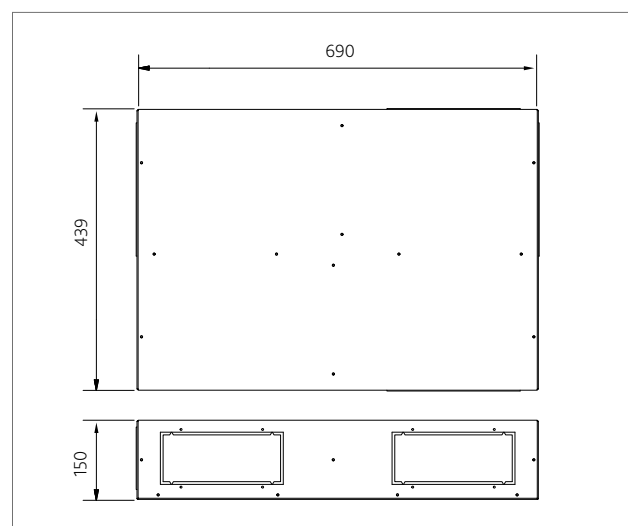
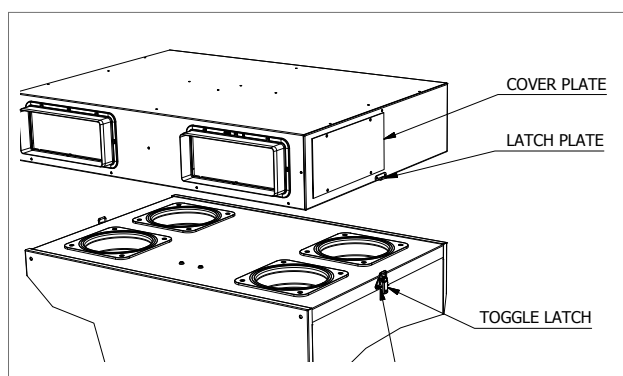
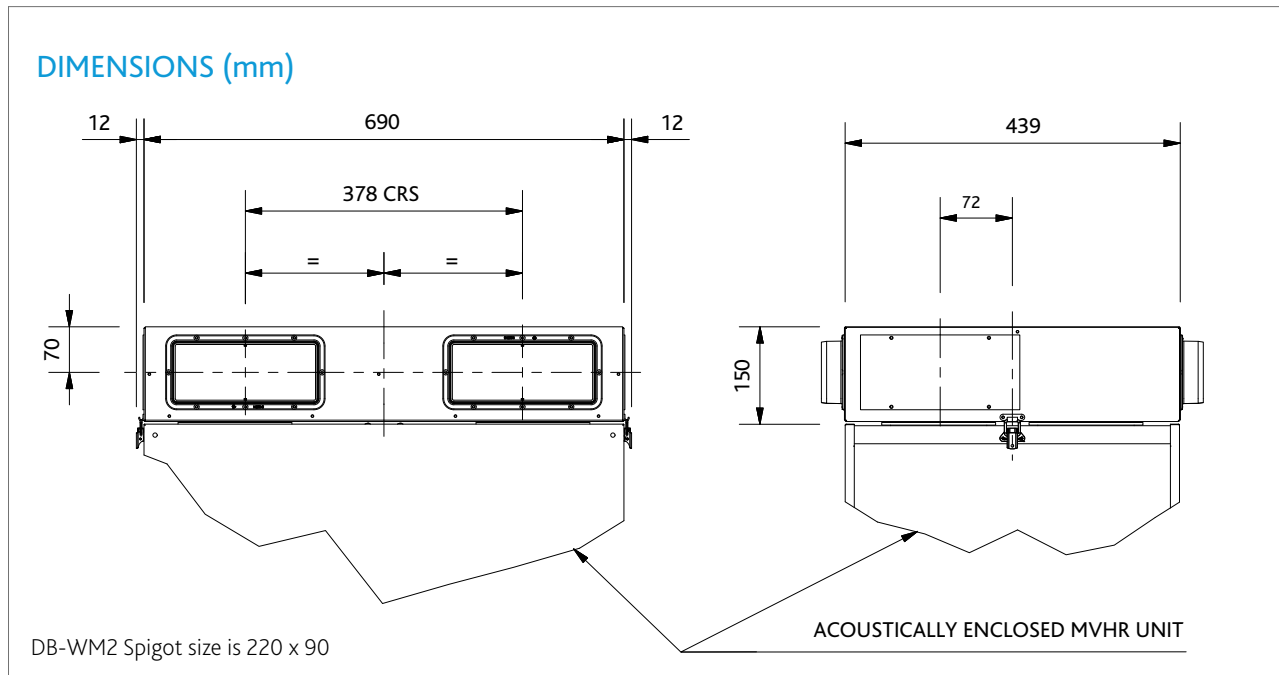

Humidity Sensor

A low voltage sensor which activates the MVHR system when the relative humidity level exceeds a set point. The MRXBOX95-HUM incorporates an overrun timer and allows the user to manually adjust the relative humidity set point.



Remote Fail Indicator

The MRXBOX95-RFI flashes warning light when fan failure occurs. This remote device will ensure you are always aware of the status of the system.



MRXBOX95-PIR (passive infra-red)

A low voltage sensor, detects movement and activates system. Incorporates overrun timer and timer adjustments.



LCD Touchscreen Controller

Simple, intuitive and discreet the Nuair LCD control- MRXBOX-VSC – puts you in total control of your MVHR system. With a wide range of functions and settings, no other product gives you the freedom to tailor performance whilst saving energy.

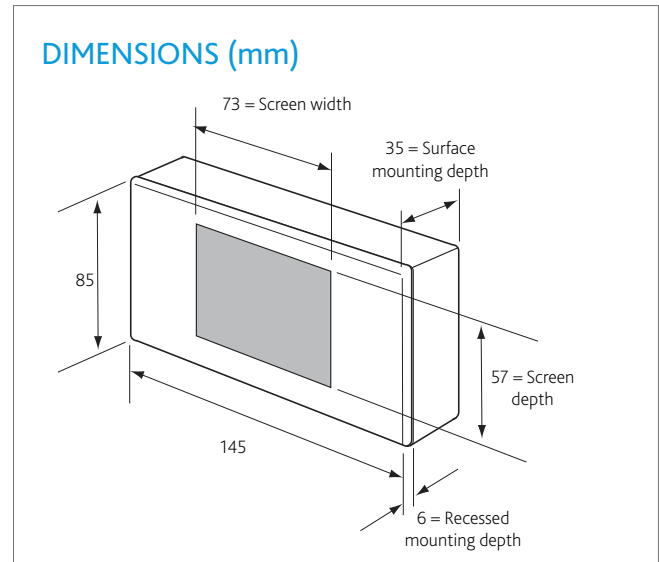

MRXBOX-VSC
CONTROL SCREEN
COMPATIBLE WITH
THIS UNIT

Technical - MRBOX95(AB)-WM2-AE

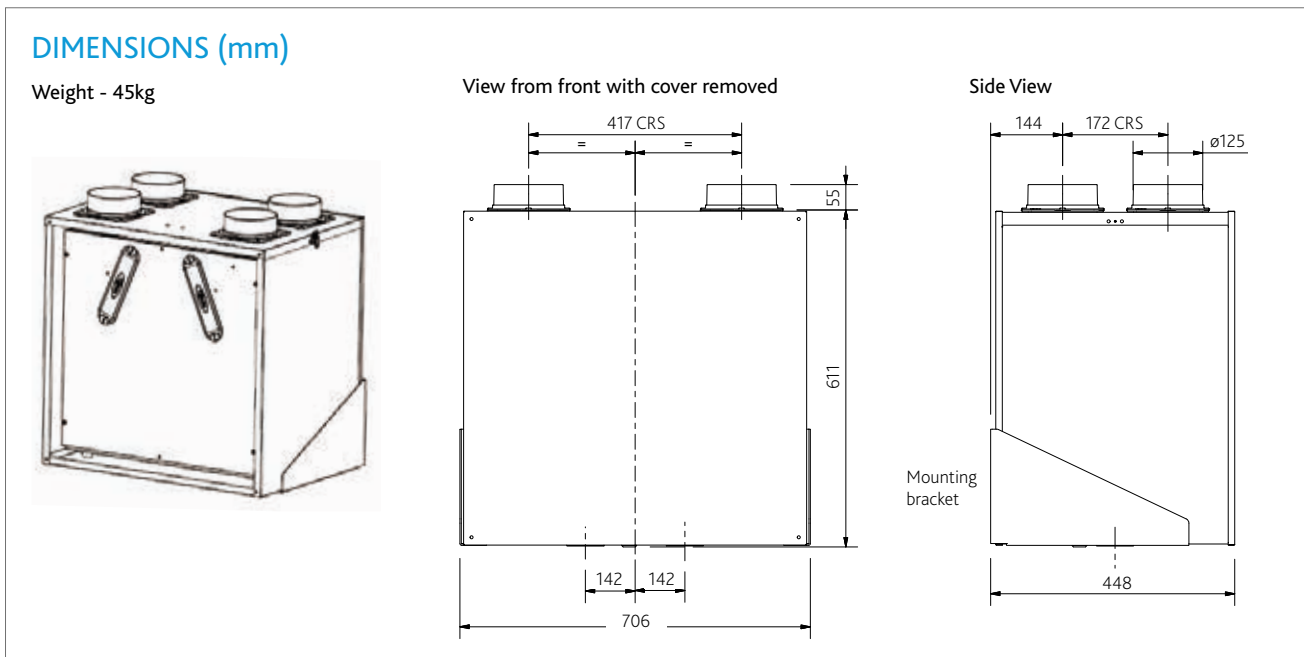

Wiring - MRBOX95(AB)-WM2-AE

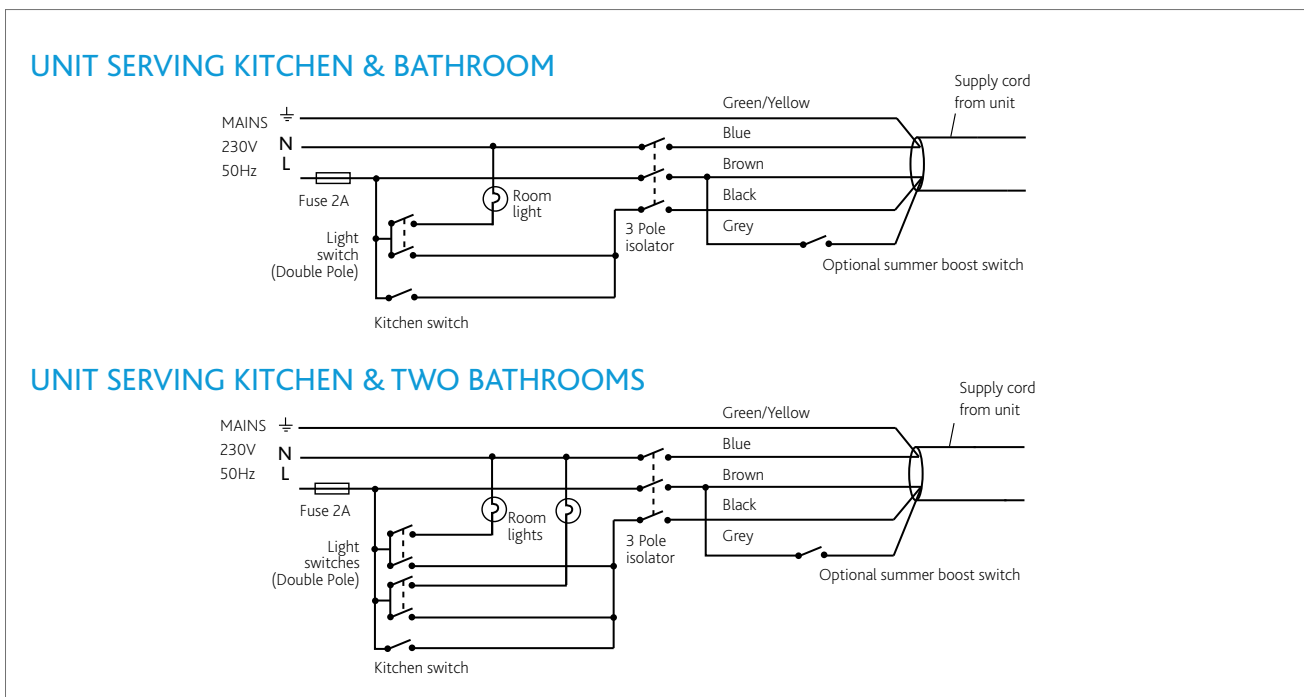

Electrical Details

Please note: the electrical connection of the unit must be carried out by a qualified electrician.

The unit is supplied with a flexible cord for connection to the mains supply.

NOTE: This unit must be earthed.

The mains power supply cable should be connected to a fixed wiring installation, via a fused isolator, in accordance with current IEE wiring regulations.

ELECTRICAL DETAILS: MRXBOX95-WM2-AE	
Voltage:	230V 1ph 50Hz
Consumption:	WH1 - 1.3 Amp
Fuse rating:	3 Amp

Consultants Specification

TECHNICAL DATA

Fan Codes: MRXBOX95AB-WM2-AE / MRXBOX95-WM2-AE / MRXBOX95AB-WM2-AE-OH / MRXBOX95-WM2-AE-OH

Acoustically Enclosed Wall Mounted Multi-room Heat Recovery unit.

SPECIFICATION

The unit shall be fully insulated providing excellent thermal and acoustic characteristics and shall be complete with a multi plate counter flow high efficiency heat exchanger block, with a thermal efficiency of up to 95%. The heat exchanger shall be protected by G3 grade filters on fresh air inlet and system extract. The heat exchanger and filters shall be accessible via the front access panel, enabling quick and easy maintenance.

The unit shall have low energy, high efficiency EC fan/motor assemblies with sealed for life bearings, the impellers shall be backward curved centrifugal type. The motors shall be suitable of an ambient temperature of 40°C.

The unit shall be supplied complete with a condensate drip tray and 21.5mm drain connection.

The unit shall be suitable for 125mm diameter circular ducting.

The breakout noise level and power requirements shall be as detailed by the unit manufacturer and in accordance with the ventilation equipment schedule.

Units shall be one of MRXBOX95AB-WM2-AE, MRXBOX95-WM2-AE, MRXBOX95AB-WM2-AE-OH, MRXBOX95-WM2-AE-OH as manufactured by Nuaire.

The unit shall be provided within a white pre-painted or coated steel acoustic enclosure lined with a minimum of 20mm class '0' acoustic foam insulation to reduce breakout noise.

Flexible duct connections shall be within the enclosure, pre-fitted between the MVHR unit and the connection spigots on the top face of the enclosure. (Removing the need for flexible duct connectors outside of the unit which may cause breakout).

The MVHR unit shall be retained within the enclosure on a metal tray supported on turret type anti-vibration mounts of suitable deflection to ensure that vibration is not transmitted to the supporting structure.

All operational components of the MVHR unit shall be accessible via the front panel of the enclosure. The enclosure shall be supported on 3mm (minimum) prefabricated steel cantilever wall brackets or other suitable fabricated steel supporting frame.

The unit shall be offered with a 5 year warranty.

The unit complies with EU regulations No.1253/2014 and No.1254/2014.

OPERATION

The supply and extract ventilation unit shall be positioned as indicated on the drawings and shall be in accordance with the particular fan schedule in the specification. This unit is also available in Opposite Hand formatting.

The combined supply and extract with heat recovery unit, shall supply filtered fresh air to each of the habitable rooms and vitiated air shall be extracted from the wet areas e.g. bathroom, en-suite, w.c, kitchen, utility

rooms, etc. The supply air shall be pre-heated by the warm extract air via the integrated counter-flow heat exchanger element. The extracted air shall also be filtered before it reaches the heat exchanger block.

The ventilation unit shall vary its speed and therefore the ventilation rate, as it receives signals from the switched live signal from light/remote switches or any ancillary sensors. When signals are received, the fan shall alter its speed to adjustable, normal and boost rates.

The unit shall have the facility to commission the supply and extract fans independently on minimum speed (continuous background ventilation), and boost speed, via inbuilt minimum and maximum speed adjustment. The fans shall have infinitely variable speed control.

INTEGRAL AUTOMATIC SUMMER BYPASS (MRXBOX95AB-WM2-AE & MRXBOX95AB-WM2-AE-OH only)

Including Automatic SUMMER BYPASS where intake and return air temperatures shall be measured so that supply air temperatures can be maximised during winter months and minimised as external ambient temperature rises. The Summer Bypass damper shall be opened by a wax actuator. Supply and Extract air shall be filtered irrespective of the bypass setting (open or closed).

Integral Humidity Sensor

The integral humidity sensor incorporated within the extract fan chamber will automatically boost both the extract and supply fan, to the commissioned boost speed, when the humidity level exceeds that set by the front panel mounted adjustment potentiometer.

CONTROL OPTIONS

All versions shall have the following functions integrally mounted within the fan unit on a purpose made PCB, all such components pre-wired and factory fitted by the manufacturer:

- Independent control of background supply and extract flow rates.
- Independent control of boost speed supply and extract flow rates.
- Integral fan failure indication.
- Integral S/L terminal for boost from remote switch, e.g. light switch, kitchen boost switch.
- Integral heat exchanger frost protection.
- Discreet daily run monitor.
- Integral humidistat.

OPTIONAL CONTROLS

MRXBOX95-RFI Remote fail indicator.
(or Volt Free contacts to allow failure indication to BMS).

MRXBOX95-PIR (Passive Infra Red)
A low voltage sensor which detects movement and activates system.
Incorporates overrun timer and timer adjustments.

MRBOX95-HUM
A low voltage sensor which activates the system when the relative humidity level is above a set point. Incorporates overrun timer and relative humidity set-point level adjustment.

MRXBOX-VSC
An LCD controller for MVHR system with a 3.2" touch screen display.
Can be surface or semi-recess mounted.

MRXBOX95-WH1-AE & MRXBOX95AB-WH1-AE

Both the MRXBOX95-WH1-AE and MRXBOX95AB-WH1-AE are designed to provide optimised balanced (supply and extract) mechanical ventilation heat recovery, all whilst being encased within our latest Acoustic Enclosure.

Tempered air is delivered into 'living areas' whilst extracting moisture laden air from 'wet areas', creating comfortable and well ventilated homes. The unit has the facility to commission the supply and extract fans independently on both minimum and maximum speeds, and the heat exchange block can recover up to 95% of the normally wasted heat that has been extracted from 'wet rooms'. The "AE" element of the above product code relates to our new Q-Aire Acoustic Enclosure, designed specifically for our MRXBOX range of heat recovery units. This new unit incorporates an acoustic surrounding to your MVHR unit and flexible duct connectors, significantly decreasing noise and vibration output.

Please note both of these units are available in Opposite Handed format. EU Energy rating A+ as per EU regulation No1254/2014. Please contact our Sales Team for further details.



Typical Installation



Limited ceiling voids in modern apartments and complex duct arrangements coupled with increased airflow demands placed on MVHR systems in an effort to reduce the risk of overheating lead to higher system resistances and running speeds.

Restrictions on utility cupboard space, practical and financial limitations frequently prevent the construction of acoustic cupboards, whilst modern light-weight wall construction methods offer little mass to absorb unit noise and vibration. This can often result in the transfer of low frequency noise and vibration into adjacent living and sleeping areas.

These factors leave designers at risk of exceeding the stringent noise requirements specified in Part F of the building regulations and further defined by CIBSE.

By integrating the MVHR unit and flexible connections within an enclosure and supporting the internals on anti-vibration mounts, noise and vibration are isolated.

Performance - MRBOX95(AB)-WH1-AE

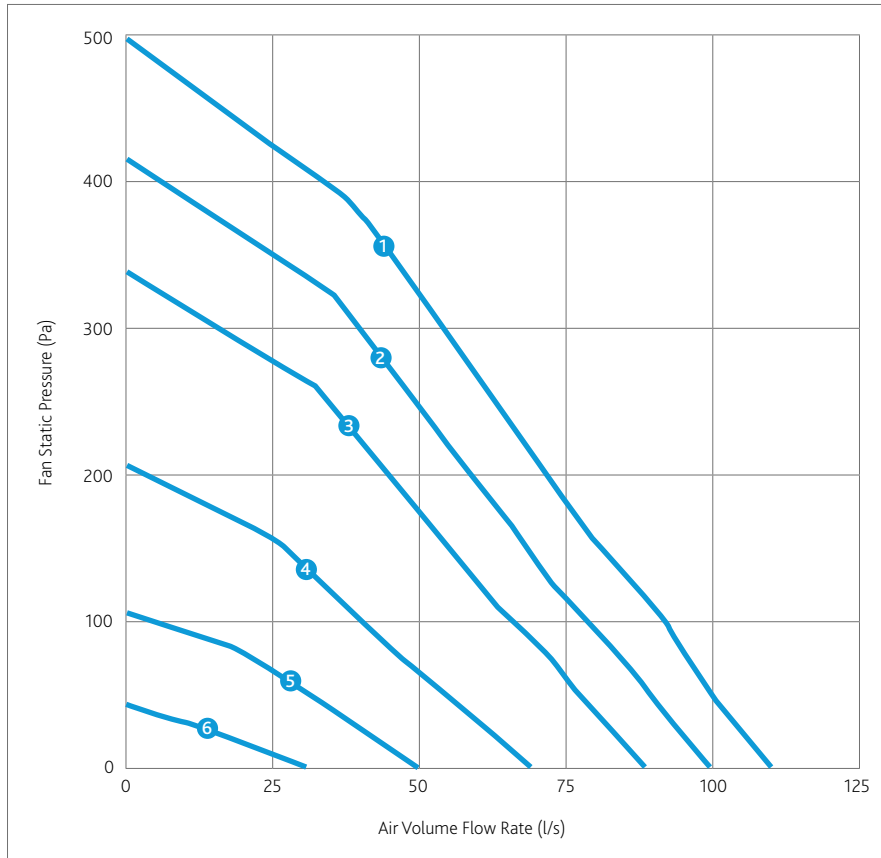

CODE DESCRIPTION

MRXBOX95-WH1-AE



1. Multi-room supply and extract heat recovery
2. Product range
3. Efficiency
4. Wall/cupboard application
5. High Duty Model 1
6. Acoustic enclosure of MVHR unit

MRXBOX95AB-WH1-AE



1. Multi-room supply and extract heat recovery
2. Product range
3. Efficiency
4. Automatic Summer Bypass
5. Wall/cupboard application
6. High Duty Model 1
7. Acoustic enclosure of MVHR unit

Electrical & Sound

WH1 Sound Data with AE fitted											
	Maximum power consumption	Frequency/Hz	63	125	250	500	1K	2K	4K	8K	dBA @3m
Curve	W	Sound Power Levels dB re 1pW									
1	150	Open Inlet	48	51	58	49	47	39	25	16	
		Open Outlet	56	63	67	67	62	60	50	41	
		Breakout	54	59	51	38	20	18	<16	<16	28
2	114	Open Inlet	48	50	57	48	45	37	23	16	
		Open Outlet	56	62	66	66	60	58	48	39	
		Breakout	54	58	50	37	18	16	<16	<16	27
3	75	Open Inlet	47	50	56	46	43	35	21	16	
		Open Outlet	55	62	65	64	58	56	46	37	
		Breakout	53	58	49	35	16	<16	<16	<16	27
4	36	Open Inlet	46	48	53	43	37	29	16	16	
		Open Outlet	54	60	62	61	52	50	40	31	
		Breakout	52	56	46	32	<16	<16	<16	<16	25
5	14	Open Inlet	44	45	50	38	30	22	16	16	
		Open Outlet	52	57	59	56	45	43	33	24	
		Breakout	50	53	43	27	<16	<16	<16	<16	22
6	8	Open Inlet	41	42	44	30	19	16	16	16	
		Open Outlet	49	54	53	48	34	32	22	16	
		Breakout	47	50	37	19	<16	<16	<16	<16	18
WH1 Sound Data with AE & DB fitted											
1	150	Open Inlet	48	44	53	44	40	30	19	<16	
		Open Outlet	52	58	61	57	53	50	43	28	
		Breakout	54	59	51	38	20	18	<16	<16	28

The maximum power consumption shown above (Watts) is consumed on units running continuously, not taking into account any heat recovery saving and based on SAP Appendix Q testing. The breakout case-radiated dBA values are given for Hemispherical free field radiation at 3m – to obtain the spherical radiated data, subtract 3dBA.

Sap Appendix Q Test Results

Product Code	MRXBOX95AB-WH1-AE			MRXBOX95-WH1-AE		
SAP Identifier	MRXBOX95AB-WH1			MRXBOX95-WH1		
Application	Specific Fan Power (W/l/s)	Heat Exchange Efficiency	Energy Saving Trust Best Practice Compliant	Specific Fan Power (W/l/s)	Heat Exchange Efficiency	Energy Saving Trust Best Practice Compliant
Kitchen + 1 Wet Room	0.52	88%	Yes	0.42	91%	Yes
Kitchen + 2 Wet Room	0.56	88%	Yes	0.50	91%	Yes
Kitchen + 3 Wet Room	0.67	88%	Yes	0.61	89%	Yes
Kitchen + 4 Wet Room	0.78	86%	Yes	0.75	88%	Yes
Kitchen + 5 Wet Room	0.95	86%	Yes	0.90	87%	Yes
Kitchen + 6 Wet Room	1.16	85%	Yes	1.05	85%	Yes
Kitchen + 7 Wet Room	1.40	85%	Yes	-	-	Yes

General Arrangement

STANDARD UNIT SPIGOT LOCATION & DUCTING REFERENCES

- Spigot 1. 150mm dia. = Extract air from dwelling
- Spigot 2. 150mm dia. = Exhaust air to outside
- Spigot 3. 150mm dia. = Intake air from outside
- Spigot 4. 150mm dia. = Supply air to property

OPPOSITE HANDED UNIT SPIGOT LOCATION & DUCTING REFERENCES

- Spigot 1. 150mm dia. = Intake air from outside
- Spigot 2. 150mm dia. = Supply air to property
- Spigot 3. 150mm dia. = Extract air from dwelling
- Spigot 4. 150mm dia. = Exhaust air to outside

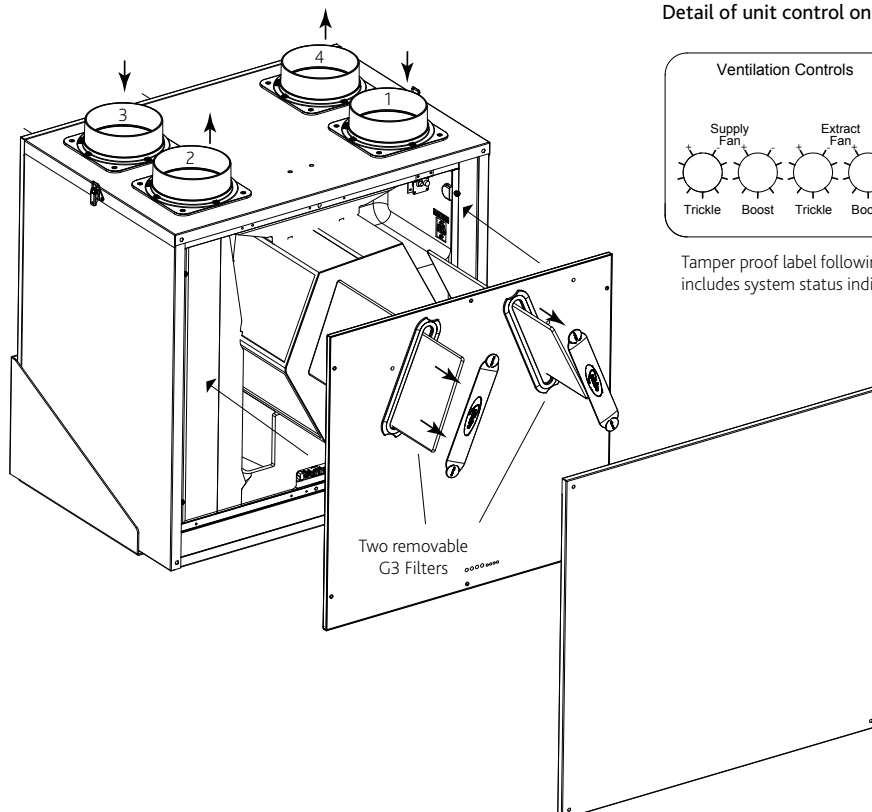

Detail of unit control on front panel.

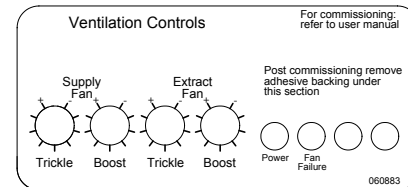

Tamper proof label following commissioning, includes system status indication.

Ancillaries

Distribution Box

The DB-WH1 is fitted on top of the MRXBOX95(AB)-WH1-AE before installation and offers a neat arrangement by directly distributing the initial ducting. It further benefits this MVHR system by reducing any in-line noise breakout, therefore improving this acoustic solution.

*For the DB-WH1 acoustic data please refer to the bottom 3 lines of the table found on pg 25.

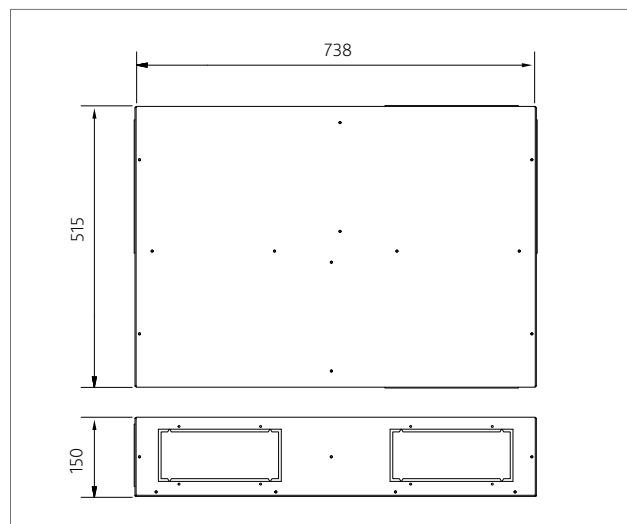
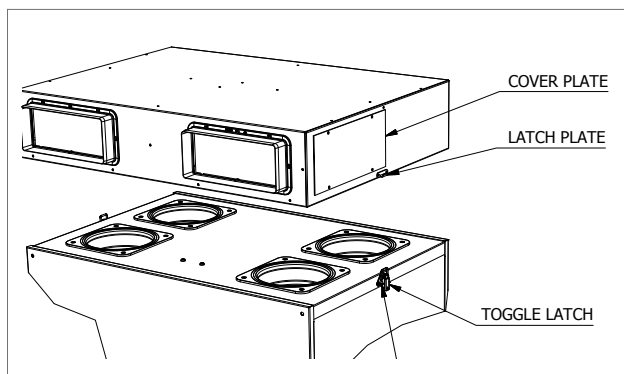
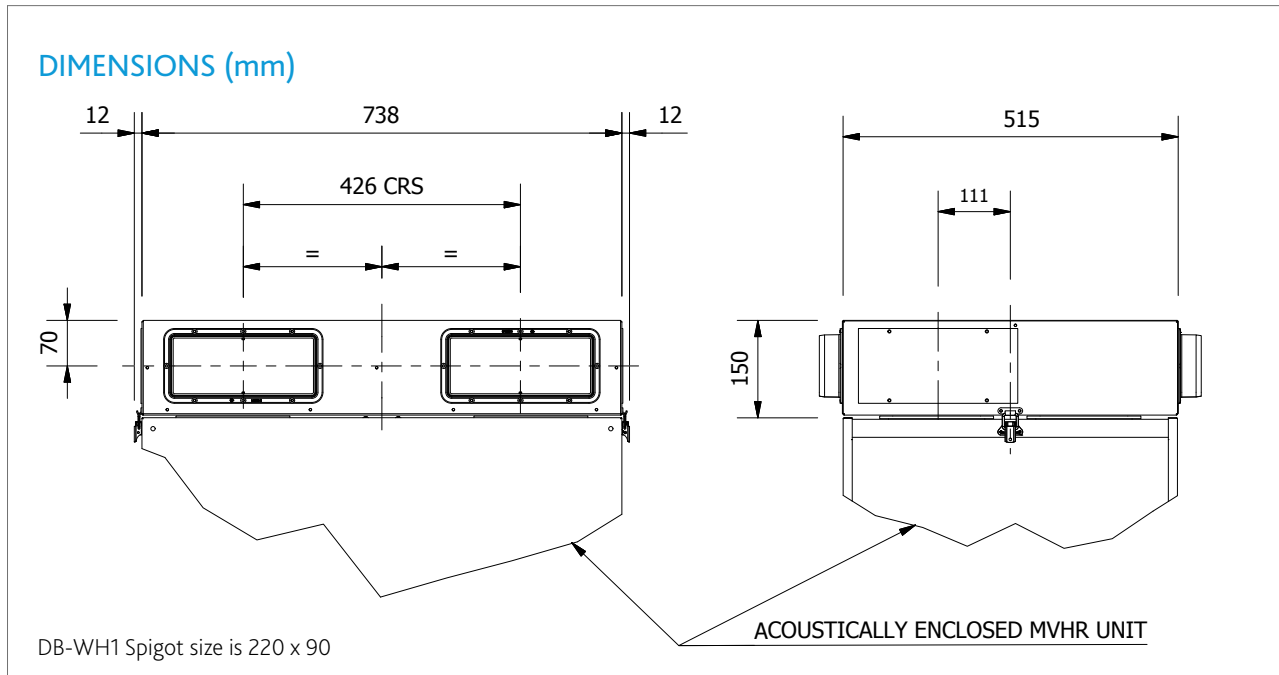

Humidity Sensor

A low voltage sensor which activates the MVHR system when the relative humidity level exceeds a set point. The MRXBOX95-HUM incorporates an overrun timer and allows the user to manually adjust the relative humidity set point.



Remote Fail Indicator

The MRXBOX95-RFI flashes warning light when fan failure occurs. This remote device will ensure you are always aware of the status of the system.



MRXBOX95-PIR (passive infra-red)

A low voltage sensor, detects movement and activates system. Incorporates overrun timer and timer adjustments.



LCD Touchscreen Controller

Simple, intuitive and discreet the Nuaire LCD control- MRXBOX-VSC – puts you in total control of your MVHR system. With a wide range of functions and settings, no other product gives you the freedom to tailor performance whilst saving energy.

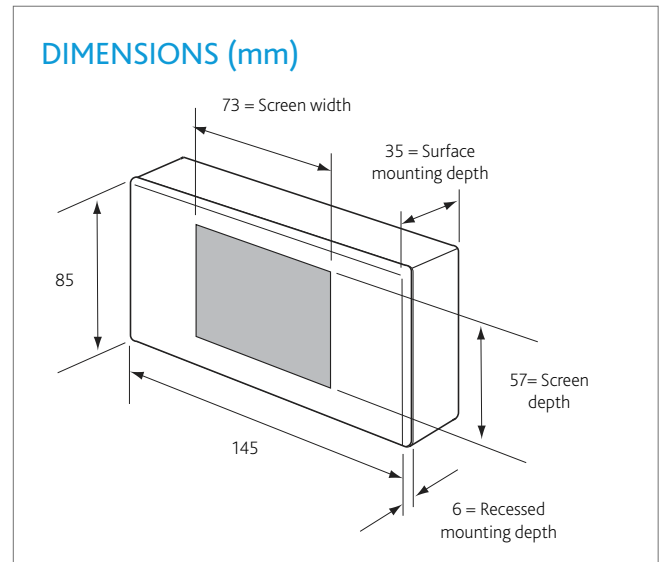

MRXBOX-VSC
 CONTROL SCREEN
 COMPATIBLE WITH
 THIS UNIT

Technical - MRBOX95(AB)-WH1-AE

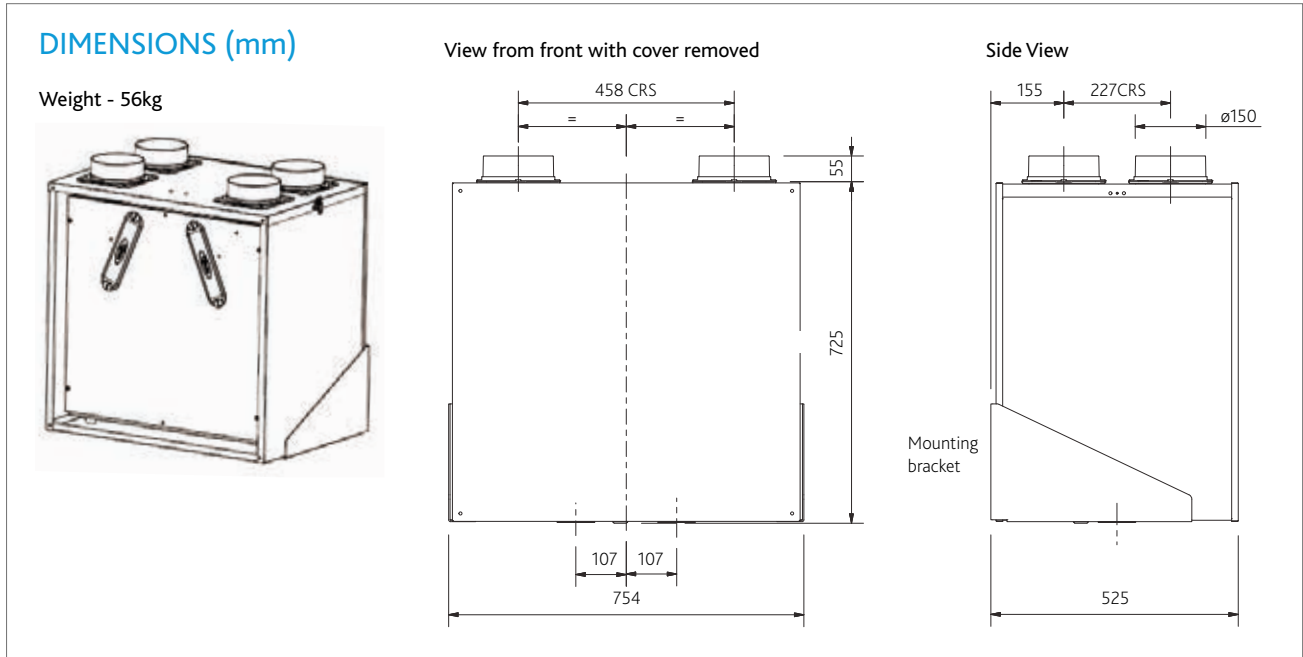

Wiring - MRBOX95(AB)-WH1-AE

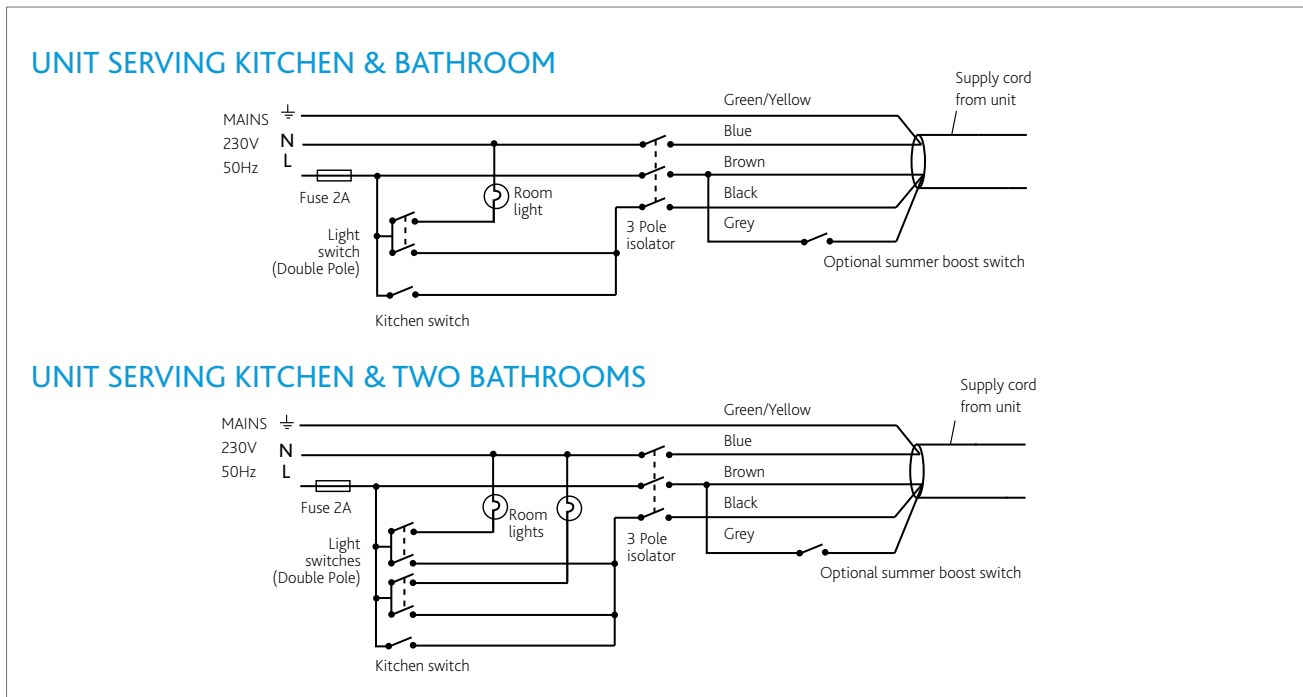

Electrical Details

Please note: the electrical connection of the unit must be carried out by a qualified electrician.

The unit is supplied with a flexible cord for connection to the mains supply.

NOTE: This unit must be earthed.

The mains power supply cable should be connected to a fixed wiring installation, via a fused isolator, in accordance with current IEE wiring regulations.

ELECTRICAL DETAILS: MRXBOX95-WH1-AE	
Voltage:	230V 1ph 50Hz
Consumption:	WH1 - 1.3 Amp
Fuse rating:	3 Amp

Consultants Specification

TECHNICAL DATA

Fan Codes: MRXBOX95AB-WH1-AE / MRXBOX95-WH1-AE / MRXBOX95AB-WH1-AE-OH / MRXBOX95-WH1-AE-OH

Acoustically Enclosed Wall Mounted Multi-room Heat Recovery unit.

SPECIFICATION

The unit shall be fully insulated providing excellent thermal and acoustic characteristics and shall be complete with a multi plate counter flow high efficiency heat exchanger block, with a thermal efficiency of up to 95%. The heat exchanger shall be protected by G3 grade filters on fresh air inlet and system extract. The heat exchanger and filters shall be accessible via the front access panel, enabling quick and easy maintenance.

The unit shall have low energy, high efficiency EC fan/motor assemblies with sealed for life bearings, the impellers shall be backward curved centrifugal type. The motors shall be suitable of an ambient temperature of 40°C.

The unit shall be supplied complete with a condensate drip tray and 21.5mm drain connection.

The unit shall be suitable for 150mm diameter circular ducting.

The breakout noise level and power requirements shall be as detailed by the unit manufacturer and in accordance with the ventilation equipment schedule.

Units shall be one of MRXBOX95AB-WH1-AE, MRXBOX95-WH1-AE, MRXBOX95AB-WH1-AE-OH, MRXBOX95-WH1-AE-OH as manufactured by Nuaire.

The unit shall be provided within a white pre-painted or coated steel acoustic enclosure lined with a minimum of 20mm class '0' acoustic foam insulation to reduce breakout noise.

Flexible duct connections shall be within the enclosure, pre-fitted between the MVHR unit and the connection spigots on the top face of the enclosure. (Removing the need for flexible duct connectors outside of the unit which may cause breakout).

The MVHR unit shall be retained within the enclosure on a metal tray supported on turret type anti-vibration mounts of suitable deflection to ensure that vibration is not transmitted to the supporting structure.

All operational components of the MVHR unit shall be accessible via the front panel of the enclosure. The enclosure shall be supported on 3mm (minimum) prefabricated steel cantilever wall brackets or other suitable fabricated steel supporting frame.

The unit shall be offered with a 5 year warranty.

The unit complies with EU regulations No.1253/2014 and No.1254/2014.

OPERATION

The supply and extract ventilation unit shall be positioned as indicated on the drawings and shall be in accordance with the particular fan schedule in the specification. This unit is also available in Opposite Hand formatting.

The combined supply and extract with heat recovery unit, shall supply filtered fresh air to each of the habitable rooms and vitiated air shall be

extracted from the wet areas e.g. bathroom, en-suite, w.c, kitchen, utility rooms, etc. The supply air shall be pre-heated by the warm extract air via the integrated counter-flow heat exchanger element. The extracted air shall also be filtered before it reaches the heat exchanger block.

The ventilation unit shall vary its speed and therefore the ventilation rate, as it receives signals from the switched live signal from light/ remote switches or any ancillary sensors. When signals are received, the fan shall alter its speed to adjustable, normal and boost rates.

The unit shall have the facility to commission the supply and extract fans independently on minimum speed (continuous background ventilation), and boost speed, via inbuilt minimum and maximum speed adjustment. The fans shall have infinitely variable speed control.

INTEGRAL AUTOMATIC SUMMER BYPASS (MRXBOX95AB-WH1-AE & MRXBOX95AB-WH1-AE-OH only)

Including Automatic SUMMER BYPASS where intake and return air temperatures shall be measured so that supply air temperatures can be maximised during winter months and minimised as external ambient temperature rises. The Summer Bypass damper shall be opened by a wax actuator. Supply and Extract air shall be filtered irrespective of the bypass setting (open or closed).

Integral Humidity Sensor

The integral humidity sensor incorporated within the extract fan chamber will automatically boost both the extract and supply fan, to the commissioned boost speed, when the humidity level exceeds that set by the front panel mounted adjustment potentiometer.

CONTROL OPTIONS

All versions shall have the following functions integrally mounted within the fan unit on a purpose made PCB, all such components pre-wired and factory fitted by the manufacturer:

- Independent control of background supply and extract flow rates.
- Independent control of boost speed supply and extract flow rates.
- Integral fan failure indication.
- Integral S/L terminal for boost from remote switch, e.g. light switch, kitchen boost switch.
- Integral heat exchanger frost protection.
- Discreet daily run monitor.
- Integral humidistat.

OPTIONAL CONTROLS

MRXBOX95-RFI Remote fail indicator. (or Volt Free contacts to allow failure indication to BMS).

MRXBOX95-PIR (Passive Infra Red)

A low voltage sensor which detects movement and activates system. Incorporates overrun timer and timer adjustments.

MRBOX95-HUM

A low voltage sensor which activates the system when the relative humidity level is above a set point. Incorporates overrun timer and relative humidity set-point level adjustment.

MRXBOX-VSC

An LCD controller for MVHR system with a 3.2" touch screen display. Can be surface or semi-recess mounted.

MRXBOX95-WM2-1Z & MRXBOX95AB-WM2-1Z

Both the MRXBOX95-WM2-1Z and MRXBOX95AB-WM2-1Z are designed to provide optimised balanced (supply and extract) mechanical ventilation heat recovery, whilst offering the best all-in-one acoustic solution on the market.

Tempered air is delivered into 'living areas' whilst extracting moisture laden air from 'wet areas', creating comfortable and well ventilated homes. The unit has the facility to commission the supply and extract fans independently on both minimum and maximum speeds, and the heat exchange block can recover up to 95% of the normally wasted heat that has been extracted from 'wet rooms'. The "1Z" element of the above product codes relates to our new Q-Aire all-in-one acoustic enclosure, designed specifically for our MRXBOX range of heat recovery units. It acts as an acoustic enclosure allowing the MVHR unit and attenuator to be entirely encased in an aesthetically pleasing model which encloses the attenuators and flexible duct connections that would otherwise be visible and unsightly, all whilst making significant reduction in case-radiated noise.

Please note both of these units are available in Opposite Handed format. EU energy ratings A+ and A respectively as per EU regulation No.1254/2014. Please contact our Sales Team for further details.



Typical Installation



Limited ceiling voids in modern apartments and complex duct arrangements coupled with increased airflow demands placed on MVHR systems in an effort to reduce the risk of overheating lead to higher system resistances and running speeds.

Restrictions on utility cupboard space, practical and financial limitations frequently prevent the construction of acoustic cupboards, whilst modern light-weight wall construction methods offer little mass to absorb unit noise and vibration. This can often result in the transfer of low frequency noise and vibration into adjacent living and sleeping areas.

These factors leave designers at risk of exceeding the stringent noise requirements specified in Part F of the building regulations and further defined by CIBSE.

By integrating the MVHR unit and flexible connections within an enclosure and supporting the internals on anti-vibration mounts, noise and vibration are isolated.

Performance - MRBOX95(AB)-WM2-1Z

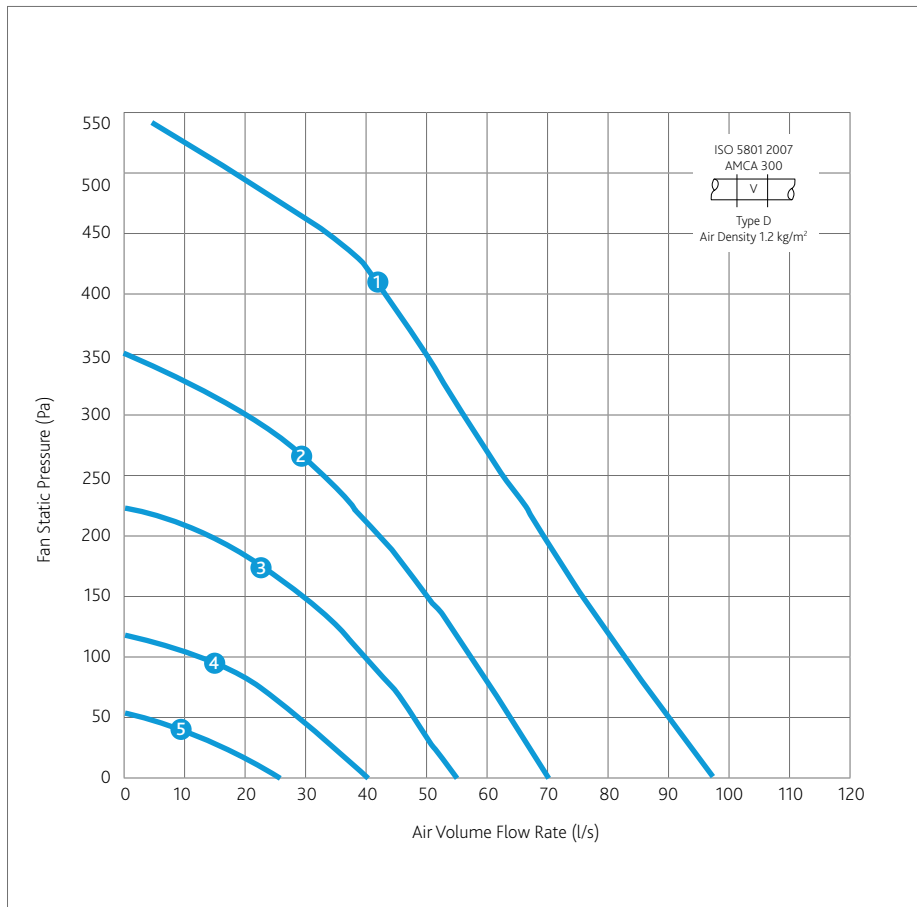

CODE DESCRIPTION

MRXBOX95-WM2-1Z

1 2 3 4 5 6

1. Multi-room supply and extract heat recovery
2. Product range
3. Efficiency
4. Wall/cupboard application
5. High Duty Model 1
6. Acoustic enclosure of MVHR unit plus Silencer

MRXBOX95AB-WM2-1Z

1 2 3 4 5 6 7

1. Multi-room supply and extract heat recovery
2. Product range
3. Efficiency
4. Automatic Summer Bypass
5. Wall/cupboard application
6. High Duty Model 1
7. Acoustic enclosure of MVHR unit plus Silencer

Electrical & Sound

WM2 Sound Data with 1Z fitted												
	Maximum power consumption	Frequency/Hz	63	125	250	500	1K	2K	4K	8K	dBA @3m	
Curve	W		Sound Power Levels dB re 1pW									
1	150	Open Inlet	49	47	46	40	28	23	19	19		
		Open Outlet	41	55	60	53	41	34	31	28		
		Breakout	56	59	48	38	23	<16	<16	17	28	
2	75	Open Inlet	43	41	40	32	18	<16	<16	<16		
		Open Outlet	39	49	50	44	32	26	19	17		
		Breakout	51	53	43	29	<16	<16	<16	<16	22	
3	36	Open Inlet	40	34	33	26	<16	<16	<16	<16		
		Open Outlet	38	46	44	39	26	19	<16	<16		
		Breakout	47	52	39	24	<16	<16	<16	<16	20	
4	14	Open Inlet	36	34	24	18	<16	<16	<16	<16		
		Open Outlet	37	42	38	34	20	<16	<16	<16		
		Breakout	44	50	36	19	<16	<16	<16	<16	18	
5	8	Open Inlet	32	29	<16	<16	<16	<16	<16	<16		
		Open Outlet	36	38	30	27	<16	<16	<16	<16		
		Breakout	41	48	31	<16	<16	<16	<16	<16	15	
WM2 Sound Data with 1Z & DB fitted											dBA @3m	
1	150	Open Inlet	49	40	41	35	21	<16	<16	<16		
		Open Outlet	37	50	54	43	32	24	24	<16		
		Breakout	56	59	48	38	23	<16	<16	17	28	

The maximum power consumption shown above (Watts) is consumed on units running continuously, not taking into account any heat recovery saving and based on SAP Appendix Q testing. The breakout case-radiated dBA values are given for Hemispherical free field radiation at 3m – to obtain the spherical radiated data, subtract 3dBA.

Sap Appendix Q Test Results

Product Code	MRXBOX95AB-WM2-1Z			MRXBOX95-WM2-1Z		
SAP Identifier	MRXBOX95AB-WM2			MRXBOX95-WM2		
Application	Specific Fan Power (W/l/s)	Heat Exchange Efficiency	Energy Saving Trust Best Practice Compliant	Specific Fan Power (W/l/s)	Heat Exchange Efficiency	Energy Saving Trust Best Practice Compliant
Kitchen + 1 Wet Room	0.56	86%	Yes	0.56	87%	Yes
Kitchen + 2 Wet Room	0.66	85%	Yes	0.68	87%	Yes
Kitchen + 3 Wet Room	0.79	84%	Yes	0.85	86%	Yes
Kitchen + 4 Wet Room	1.02	83%	Yes	1.06	86%	Yes
Kitchen + 5 Wet Room	1.23	82%	Yes	-	-	Yes

General Arrangement

STANDARD UNIT SPIGOT LOCATION & DUCTING REFERENCES

- Spigot 1. 125mm dia. = Extract air from dwelling
- Spigot 2. 125mm dia. = Exhaust air to outside
- Spigot 3. 125mm dia. = Intake air from outside
- Spigot 4. 125mm dia. = Supply air to property

OPPOSITE HANDED UNIT SPIGOT LOCATION & DUCTING REFERENCES

- Spigot 1. 125mm dia. = Intake air from outside
- Spigot 2. 125mm dia. = Supply air to property
- Spigot 3. 125mm dia. = Extract air from dwelling
- Spigot 4. 125mm dia. = Exhaust air to outside

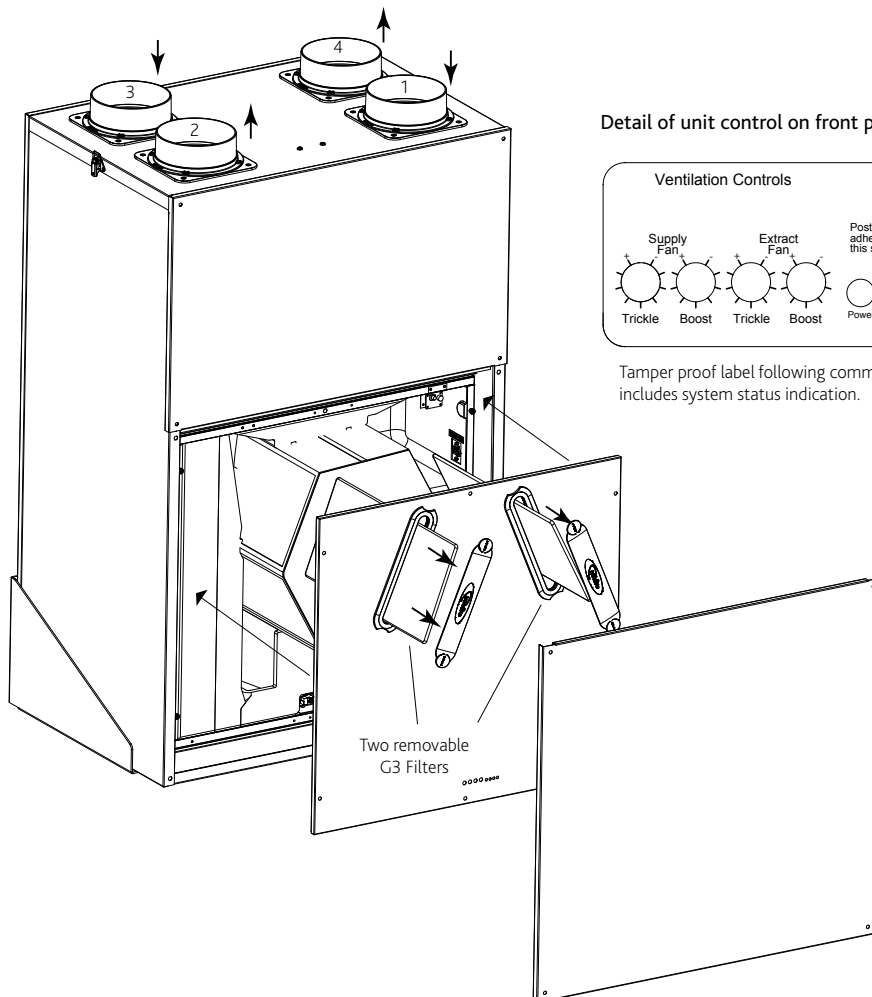

Detail of unit control on front panel.

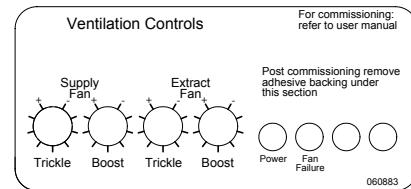

Tamper proof label following commissioning, includes system status indication.

Ancillaries

Distribution Box

The DB-WM2 is fitted on top of the MRXBOX95(AB)-WM2-1Z before installation and offers a neat arrangement by directly distributing the initial ducting. It further benefits this MVHR system by reducing any in-line noise breakout, therefore improving this acoustic solution.

*For the DB-WM2 acoustic data please refer to the bottom 3 lines of the table found on pg 32.

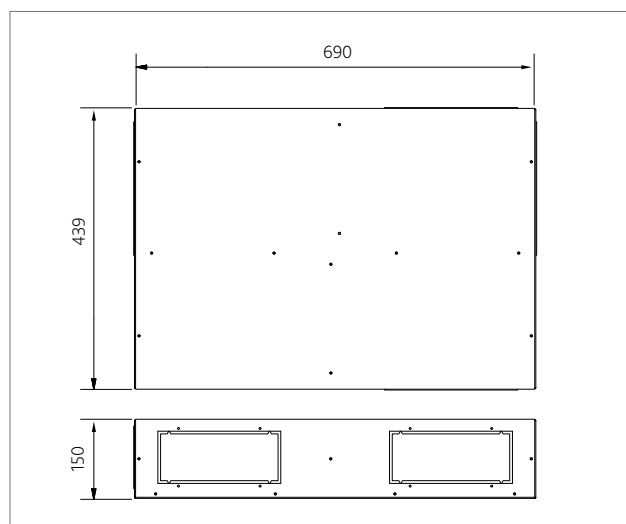
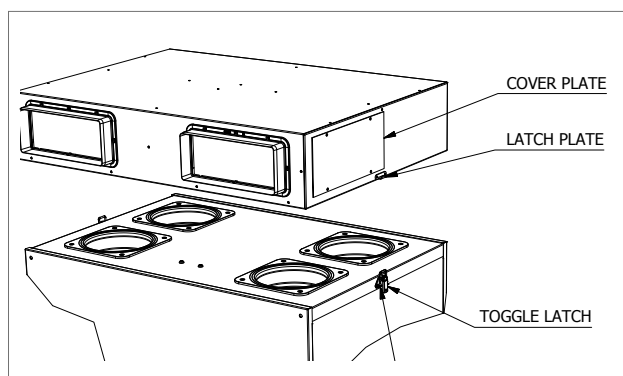
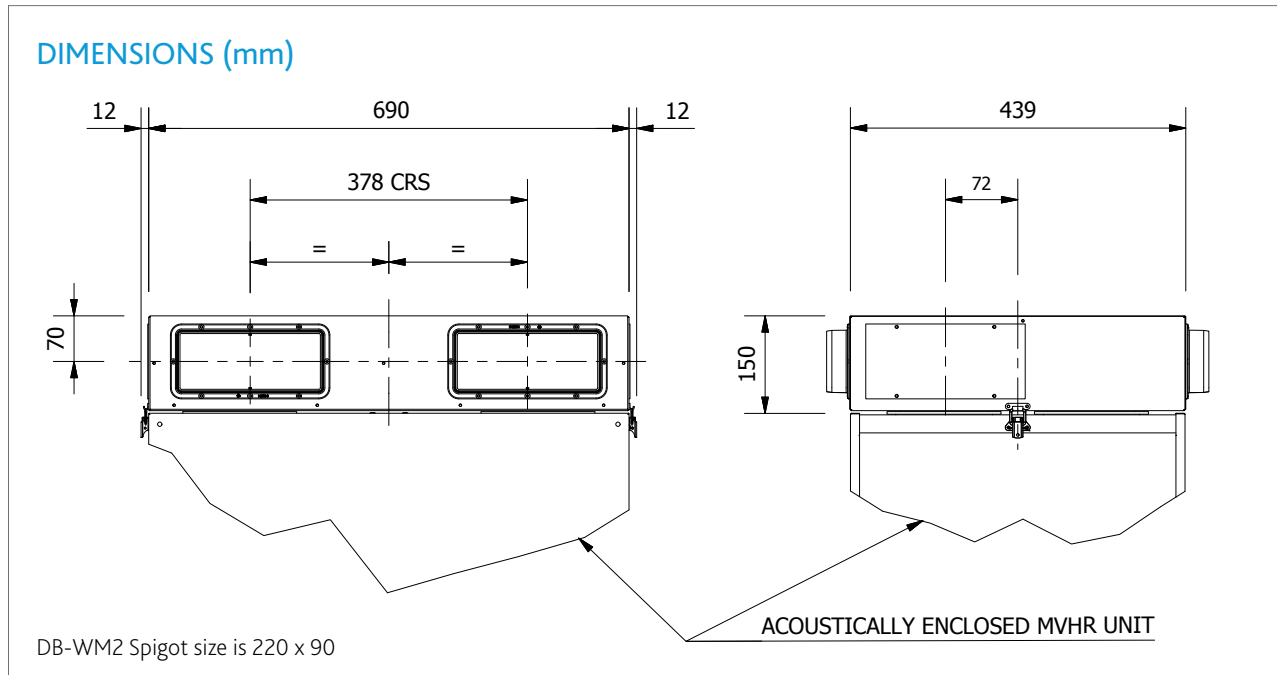

Humidity Sensor

A low voltage sensor which activates the MVHR system when the relative humidity level exceeds a set point. The MRXBOX95-HUM incorporates an overrun timer and allows the user to manually adjust the relative humidity set point.



Remote Fail Indicator

The MRXBOX95-RFI flashes warning light when fan failure occurs. This remote device will ensure you are always aware of the status of the system.



MRXBOX95-PIR (passive infra-red)

A low voltage sensor, detects movement and activates system. Incorporates overrun timer and timer adjustments.



LCD Touchscreen Controller

Simple, intuitive and discreet the Nuair LCD control- MRXBOX-VSC – puts you in total control of your MVHR system. With a wide range of functions and settings, no other product gives you the freedom to tailor performance whilst saving energy.

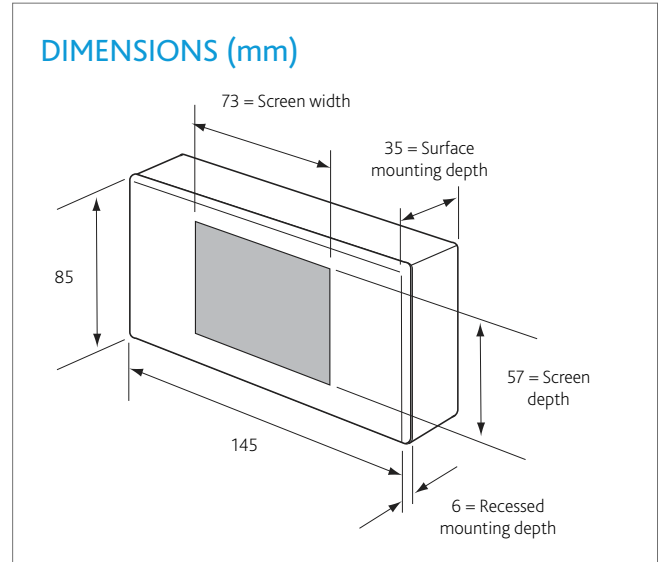

MRXBOX-VSC
CONTROL SCREEN
COMPATIBLE WITH
THIS UNIT

Technical - MRBOX95(AB)-WM2-1Z

DIMENSIONS (mm)

Weight - 58kg



View from front with cover removed

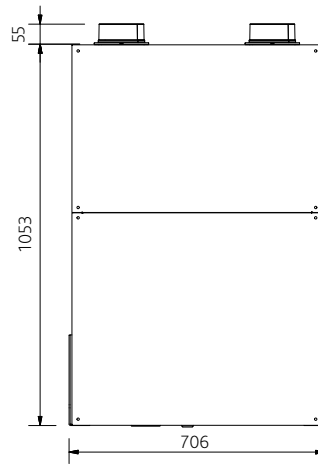

Side View



Wiring - MRBOX95(AB)-WM2-1Z

UNIT SERVING KITCHEN & BATHROOM

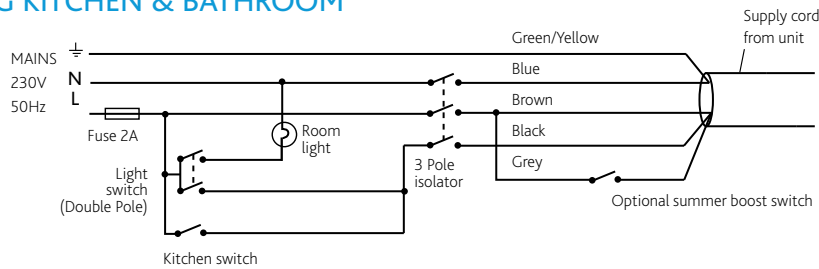

UNIT SERVING KITCHEN & TWO BATHROOMS

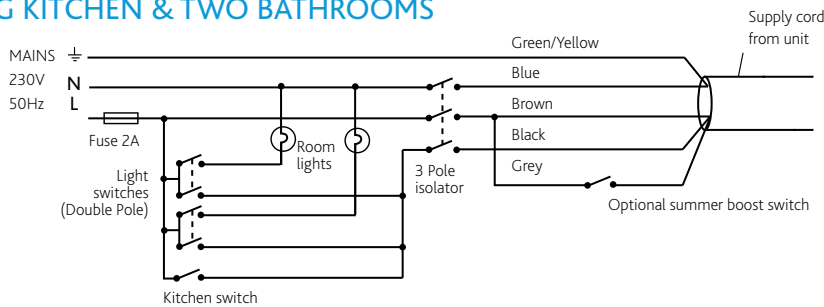

Electrical Details

Please note: the electrical connection of the unit must be carried out by a qualified electrician.

The unit is supplied with a flexible cord for connection to the mains supply.

NOTE: This unit must be earthed.

The mains power supply cable should be connected to a fixed wiring installation, via a fused isolator, in accordance with current IEE wiring regulations.

ELECTRICAL DETAILS: MRXBOX95-WM2 1Z	
Voltage:	230V 1ph 50Hz
Consumption:	WM2 - 1.3 Amp
Fuse rating:	3 Amp

Technical Data

Fan Codes: MRXBOX95AB-WM2-1Z / MRXBOX95-WM2-1Z / MRXBOX95AB-WM2-1Z-OH / MRXBOX95-WM2-1Z-OH

Acoustically Enclosed Wall Mounted Multi-room Heat Recovery unit.

SPECIFICATION

The unit shall be fully insulated providing excellent thermal and acoustic characteristics and shall be complete with a multi plate counter flow high efficiency heat exchanger block, with a thermal efficiency of up to 95%. The heat exchanger shall be protected by G3 grade filters on fresh air inlet and system extract. The heat exchanger and filters shall be accessible via the front access panel, enabling quick and easy maintenance.

The unit shall have low energy, high efficiency EC fan/motor assemblies with sealed for life bearings, the impellers shall be backward curved centrifugal type. The motors shall be suitable of an ambient temperature of 40°C.

The unit shall be supplied complete with a condensate drip tray and 21.5mm drain connection.

The unit shall be suitable for 125mm diameter circular ducting. The breakout noise level and power requirements shall be as detailed by the unit manufacturer and in accordance with the ventilation equipment schedule. Units shall be one of MRXBOX95AB-WM2-1Z, MRXBOX95-WM2-1Z, MRXBOX95AB-WM2-1Z-OH, MRXBOX95-WM2-1Z-OH as manufactured by Nuaire.

The unit shall be provided within a white pre-painted or coated steel acoustic enclosure lined with a minimum of 20mm class '0' acoustic foam insulation to reduce breakout noise.

In-duct noise shall be attenuated on Intake/Exhaust/Supply/Extract by means of a 4-way attenuator mounted within the enclosure and close coupled directly to the unit. Flexible duct connections shall be within the enclosure, pre-fitted between the attenuator section and the connection spigots on the top face of the enclosure. (Removing the need for flexible duct connectors outside of the unit which may cause breakout).

The MVHR unit and attenuator assembly shall be retained within the enclosure on a metal tray supported on turret type anti-vibration mounts of suitable deflection to ensure that vibration is not transmitted to the supporting structure.

All operational components of the MVHR unit shall be accessible via the front panel of the enclosure. The enclosure shall be supported on 3mm (minimum) prefabricated steel cantilever wall brackets or other suitable fabricated steel supporting frame. The unit shall be offered with a 5 year warranty.

The unit complies with EU regulations No.1253/2014 and No.1254/2014.

OPERATION

The supply and extract ventilation unit shall be positioned as indicated on the drawings and shall be in accordance with the particular fan schedule in the specification. This unit is also available in Opposite Hand formatting.

The combined supply and extract with heat recovery unit, shall supply filtered fresh air to each of the habitable rooms and vitiated air shall be extracted from the wet areas e.g. bathroom, en-suite, w.c, kitchen, utility

rooms, etc. The supply air shall be pre-heated by the warm extract air via the integrated counter-flow heat exchanger element. The extracted air shall also be filtered before it reaches the heat exchanger block.

The ventilation unit shall vary its speed and therefore the ventilation rate, as it receives signals from the switched live signal from light/remote switches or any ancillary sensors. When signals are received, the fan shall alter its speed to adjustable, normal and boost rates.

The unit shall have the facility to commission the supply and extract fans independently on minimum speed (continuous background ventilation), and boost speed, via inbuilt minimum and maximum speed adjustment. The fans shall have infinitely variable speed control.

INTEGRAL AUTOMATIC SUMMER BYPASS (MRXBOX95AB-WM2-1Z & MRXBOX95AB-WM2-1Z-OH only)

Including Automatic SUMMER BYPASS where intake and return air temperatures shall be measured so that supply air temperatures can be maximised during winter months and minimised as external ambient temperature rises. The Summer Bypass damper shall be opened by a wax actuator. Supply and Extract air shall be filtered irrespective of the bypass setting (open or closed).

Integral Humidity Sensor

The integral humidity sensor incorporated within the extract fan chamber will automatically boost both the extract and supply fan, to the commissioned boost speed, when the humidity level exceeds that set by the front panel mounted adjustment potentiometer.

CONTROL OPTIONS

All versions shall have the following functions integrally mounted within the fan unit on a purpose made PCB, all such components pre-wired and factory fitted by the manufacturer:

- Independent control of background supply and extract flow rates.
- Independent control of boost speed supply and extract flow rates.
- Integral fan failure indication.
- Integral S/L terminal for boost from remote switch, e.g. light switch, kitchen boost switch.
- Integral heat exchanger frost protection.
- Discreet daily run monitor.
- Integral humidistat.

OPTIONAL CONTROLS MRXBOX95-RFI

Remote fail indicator. (or Volt Free contacts to allow failure indication to BMS).

MRXBOX95-PIR (Passive Infra Red)

A low voltage sensor which detects movement and activates system. Incorporates overrun timer and timer adjustments.

MRBOX95-HUM

A low voltage sensor which activates the system when the relative humidity level is above a set point. Incorporates overrun timer and relative humidity set-point level adjustment.

MRXBOX-VSC

An LCD controller for MVHR system with a 3.2" touch screen display. Can be surface or semi-recess mounted.

MRXBOX95-WH1-1Z & MRXBOX95AB-WH1-1Z

Both the MRXBOX95-WH-1Z and MRXBOX95AB-WH-1Z are designed to provide optimised balanced (supply and extract) mechanical ventilation heat recovery, whilst offering the best all-in-one acoustic solution on the market.

Tempered air is delivered into 'living areas' whilst extracting moisture laden air from 'wet areas', creating comfortable and well ventilated homes. The unit has the facility to commission the supply and extract fans independently on both minimum and maximum speeds, and the heat exchange block can recover up to 95% of the normally wasted heat that has been extracted from 'wet rooms'. The "1Z" element of the above product codes relates to our new Q-Aire all-in-one acoustic enclosure, designed specifically for our MRXBOX range of heat recovery units. It acts as an acoustic enclosure allowing the MVHR unit and attenuator to be entirely encased in an aesthetically pleasing model which encloses the attenuators and flexible duct connections that would otherwise be visible and unsightly, all whilst making significant reduction in case-radiated noise.

Please note both of these units are available in Opposite Handed format. EU Energy rating A+ as per EU regulation No. 1254/2014. Please contact our Sales Team for further details.



Typical Installation



Limited ceiling voids in modern apartments and complex duct arrangements coupled with increased airflow demands placed on MVHR systems in an effort to reduce the risk of overheating lead to higher system resistances and running speeds.

Restrictions on utility cupboard space, practical and financial limitations frequently prevent the construction of acoustic cupboards, whilst modern light-weight wall construction methods offer little mass to absorb unit noise and vibration. This can often result in the transfer of low frequency noise and vibration into adjacent living and sleeping areas.

These factors leave designers at risk of exceeding the stringent noise requirements specified in Part F of the building regulations and further defined by CIBSE.

By integrating the MVHR unit and flexible connections within an enclosure and supporting the internals on anti-vibration mounts, noise and vibration are isolated.

Performance - MRBOX95(AB)-WH1-1Z

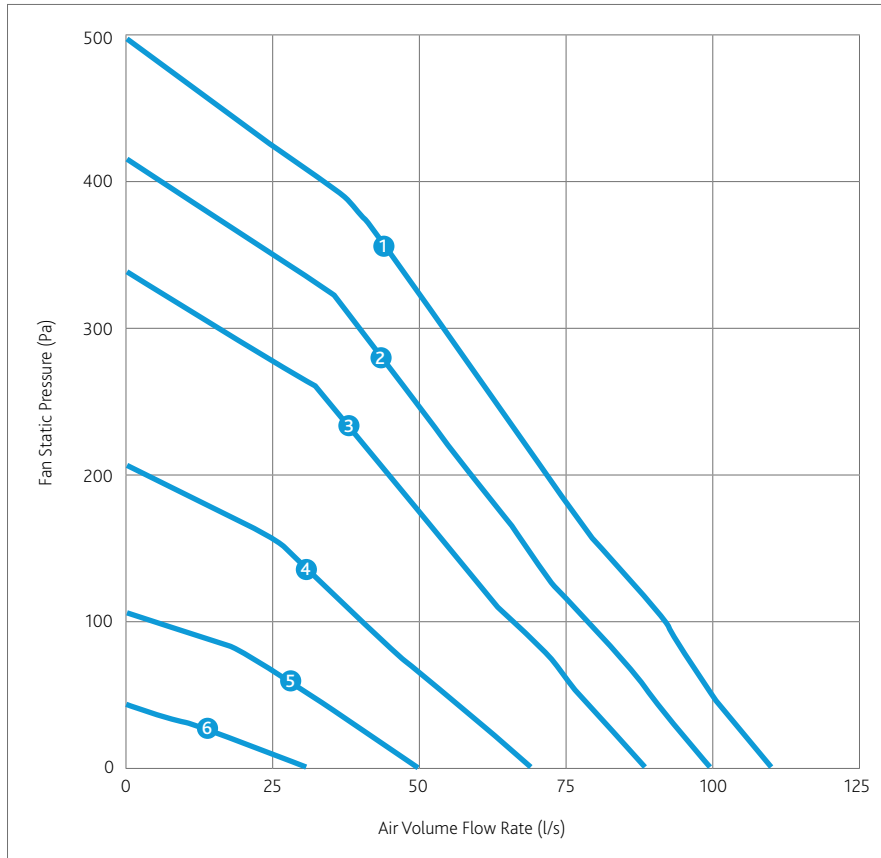

CODE DESCRIPTION

MRXBOX95-WH1-1Z

1 2 3 4 5 6

1. Multi-room supply and extract heat recovery
2. Product range
3. Efficiency
4. Wall/cupboard application
5. High Duty Model 1
6. Acoustic enclosure of MVHR unit plus Silencer

MRXBOX95AB-WH1-1Z

1 2 3 4 5 6 7

1. Multi-room supply and extract heat recovery
2. Product range
3. Efficiency
4. Automatic Summer Bypass
5. Wall/cupboard application
6. High Duty Model 1
7. Acoustic enclosure of MVHR unit plus Silencer

Electrical & Sound

WH1 Sound Data with 1Z fitted											
	Maximum power consumption	Frequency/Hz	63	125	250	500	1K	2K	4K	8K	dBA @3m
Curve	W	Sound Power Levels dB re 1pW									
1	150	Open Inlet	40	41	43	33	25	<16	<16	<16	
		Open Outlet	42	53	56	53	39	34	30	26	
		Breakout	51	59	51	38	19	<16	<16	<16	28
2	114	Open Inlet	40	40	42	32	23	<16	<16	<16	
		Open Outlet	42	52	55	52	37	32	28	24	
		Breakout	51	58	50	37	17	<16	<16	<16	27
3	75	Open Inlet	39	40	41	30	21	<16	<16	<16	
		Open Outlet	41	52	54	50	35	30	26	22	
		Breakout	50	58	49	35	15	<16	<16	<16	27
4	36	Open Inlet	38	38	38	27	<16	<16	<16	<16	
		Open Outlet	40	50	51	47	29	24	20	<16	
		Breakout	49	56	46	32	<16	<16	<16	<16	25
5	14	Open Inlet	36	35	35	22	8	<16	<16	<16	
		Open Outlet	38	47	48	42	22	17	<16	<16	
		Breakout	47	53	43	27	<16	<16	<16	<16	21
6	8	Open Inlet	33	32	29	14	<16	<16	<16	<16	
		Open Outlet	35	44	42	34	<16	<16	<16	<16	
		Breakout	44	50	37	19	<16	<16	<16	<16	18
WH1 Sound Data with 1Z & DB fitted											
1	150	Open Inlet	40	34	38	28	18	<16	<16	<16	
		Open Outlet	38	48	50	43	30	24	23	<16	
		Breakout	51	59	51	38	19	<16	<16	<16	28

The maximum power consumption shown above (Watts) is consumed on units running continuously, not taking into account any heat recovery saving and based on SAP Appendix Q testing. The breakout case-radiated dBA values are given for Hemispherical free field radiation at 3m – to obtain the spherical radiated data, subtract 3dBA.

Sap Appendix Q Test Results

Product Code	MRXBOX95AB-WH1-1Z			MRXBOX95-WH1-1Z		
SAP Identifier	MRXBOX95AB-WH1			MRXBOX95-WH1		
Application	Specific Fan Power (W/l/s)	Heat Exchange Efficiency	Energy Saving Trust Best Practice Compliant	Specific Fan Power (W/l/s)	Heat Exchange Efficiency	Energy Saving Trust Best Practice Compliant
Kitchen + 1 Wet Room	0.52	88%	Yes	0.42	91%	Yes
Kitchen + 2 Wet Room	0.56	88%	Yes	0.50	91%	Yes
Kitchen + 3 Wet Room	0.67	88%	Yes	0.61	89%	Yes
Kitchen + 4 Wet Room	0.78	86%	Yes	0.75	88%	Yes
Kitchen + 5 Wet Room	0.95	86%	Yes	0.90	87%	Yes
Kitchen + 6 Wet Room	1.16	85%	Yes	1.05	85%	Yes
Kitchen + 7 Wet Room	1.40	85%	Yes	-	-	Yes

General Arrangement

STANDARD UNIT SPIGOT LOCATION & DUCTING REFERENCES

- Spigot 1. 150mm dia. = Extract air from dwelling
- Spigot 2. 150mm dia. = Exhaust air to outside
- Spigot 3. 150mm dia. = Intake air from outside
- Spigot 4. 150mm dia. = Supply air to property

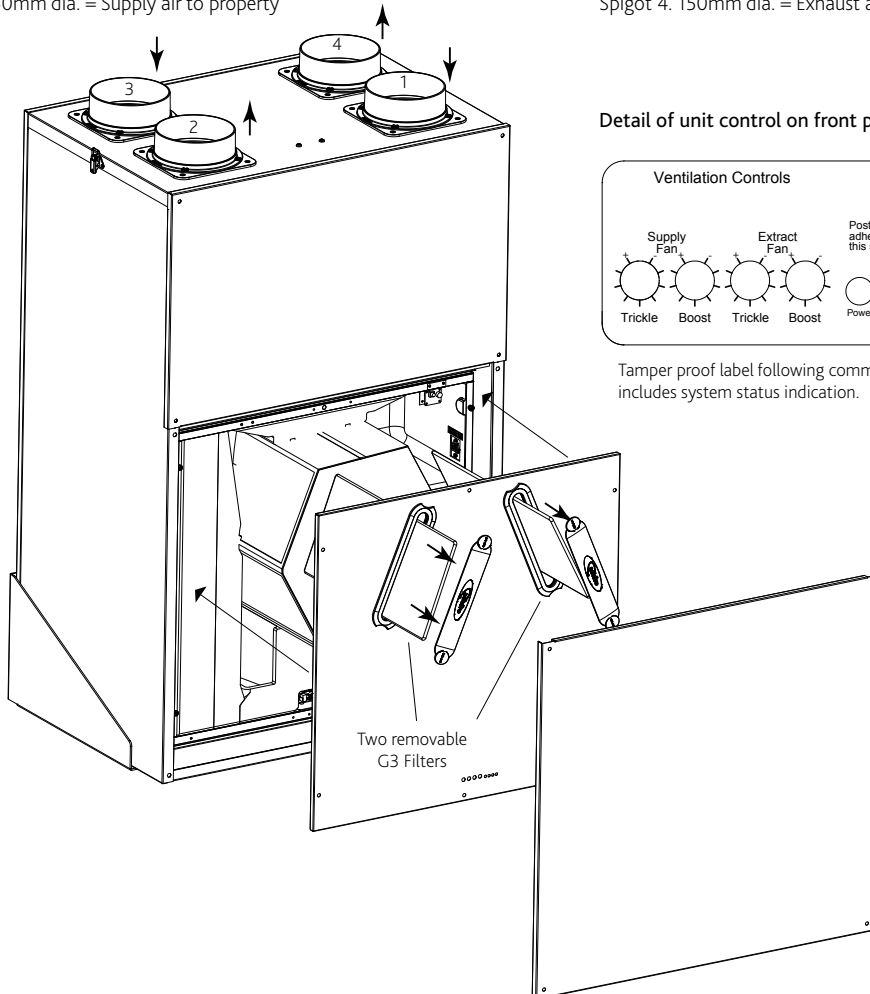

OPPOSITE HANDED UNIT SPIGOT LOCATION & DUCTING REFERENCES

- Spigot 1. 150mm dia. = Intake air from outside
- Spigot 2. 150mm dia. = Supply air to property
- Spigot 3. 150mm dia. = Extract air from dwelling
- Spigot 4. 150mm dia. = Exhaust air to outside

Detail of unit control on front panel.

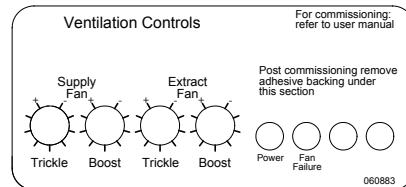

Tamper proof label following commissioning, includes system status indication.

Ancillaries

Distribution Box

The DB-WH1 is fitted on top of the MRXBOX95(AB)-WH1-1Z before installation and offers a neat arrangement by directly distributing the initial ducting. It further benefits this MVHR system by reducing any in-line noise breakout, therefore improving this acoustic solution.

*For the DB-WH1 acoustic data please refer to the bottom 3 lines of the table found on pg 39.

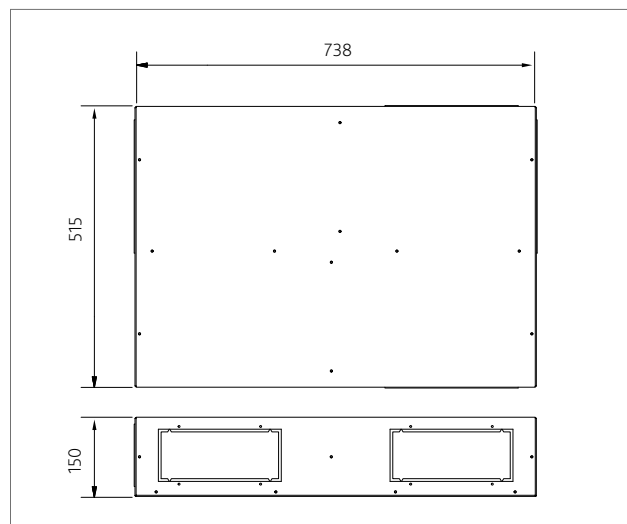
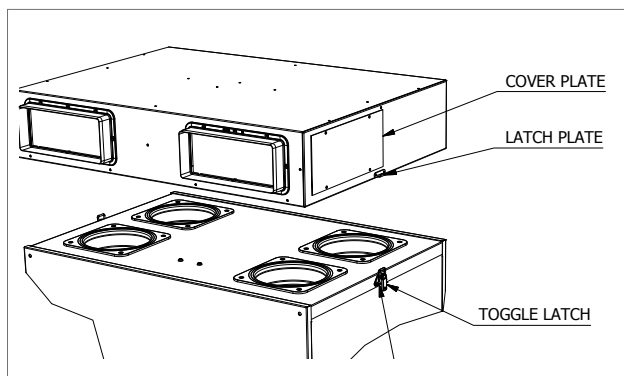
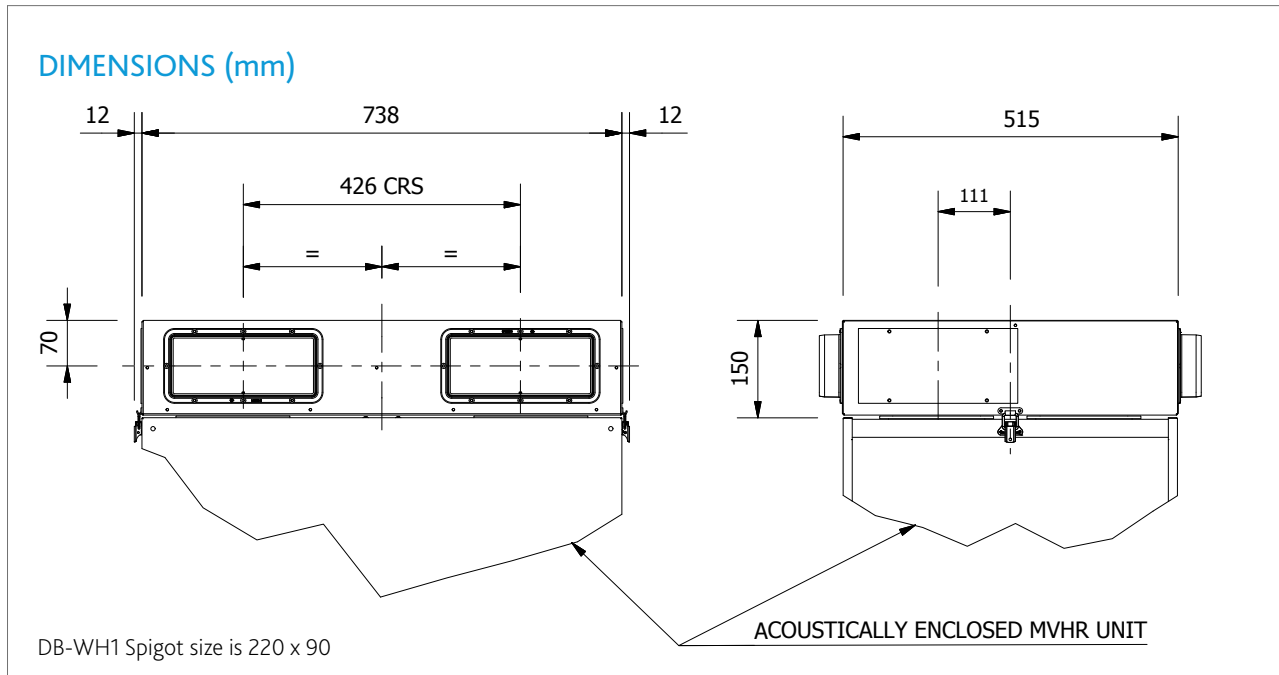

Humidity Sensor

A low voltage sensor which activates the MVHR system when the relative humidity level exceeds a set point. The MRXBOX95-HUM incorporates an overrun timer and allows the user to manually adjust the relative humidity set point.



Remote Fail Indicator

The MRXBOX95-RFI flashes warning light when fan failure occurs. This remote device will ensure you are always aware of the status of the system.



MRXBOX95-PIR (passive infra-red)

A low voltage sensor, detects movement and activates system. Incorporates overrun timer and timer adjustments.



LCD Touchscreen Controller

Simple, intuitive and discreet the Nuaire LCD control- MRXBOX-VSC – puts you in total control of your MVHR system. With a wide range of functions and settings, no other product gives you the freedom to tailor performance whilst saving energy.

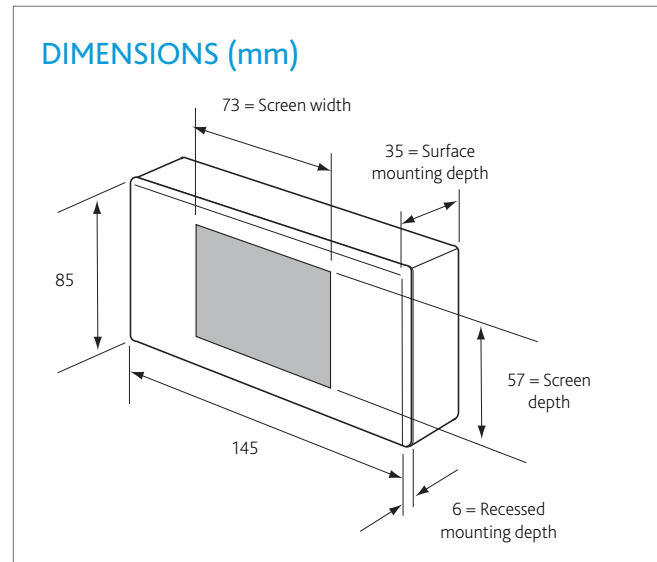

MRXBOX-VSC
 CONTROL SCREEN
 COMPATIBLE WITH
 THIS UNIT

Technical - MRBOX95(AB)-WH1-1Z

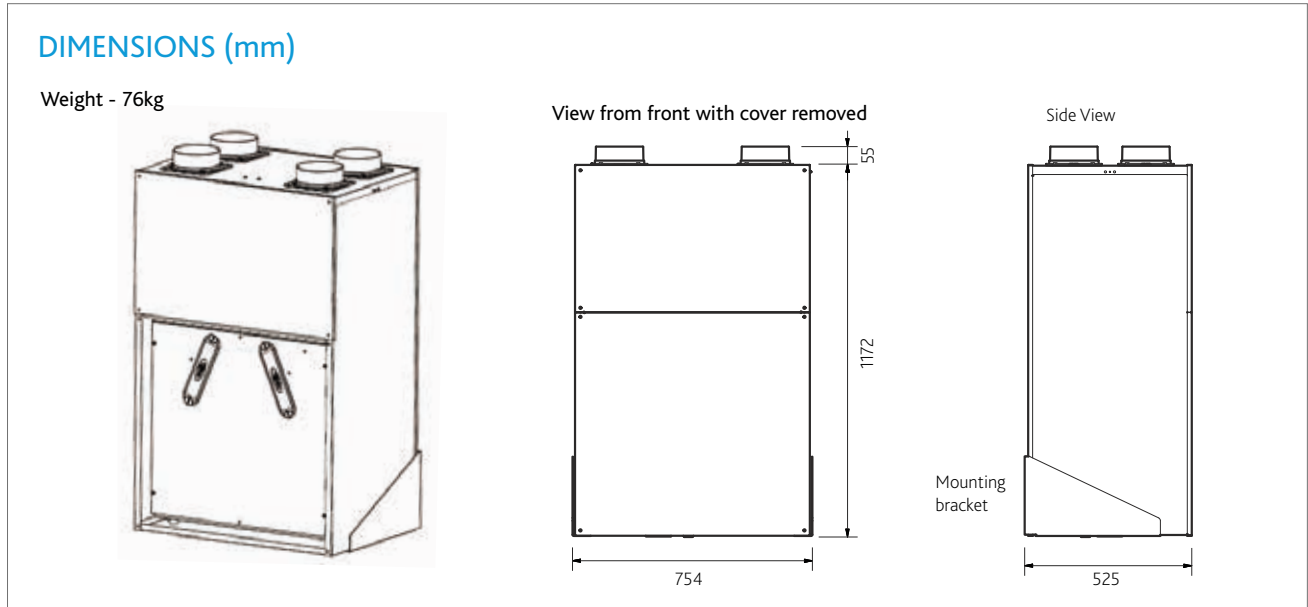

Wiring - MRBOX95(AB)-WH1-1Z

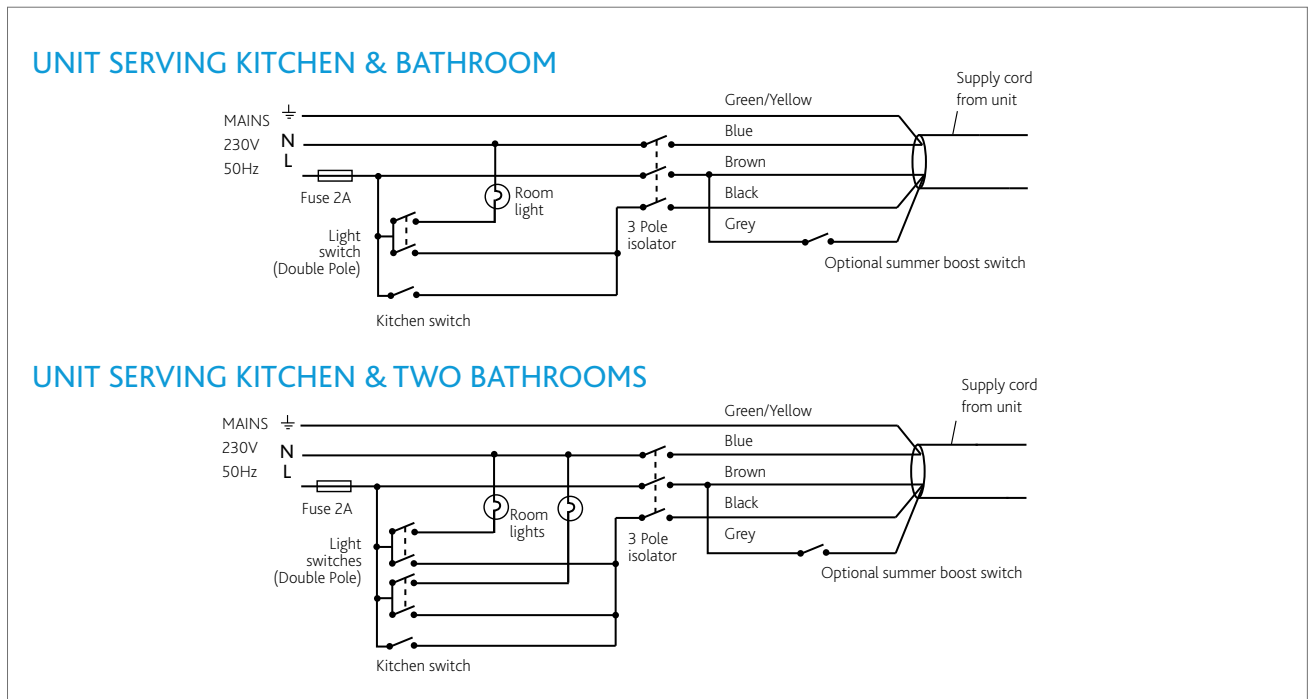

Electrical Details

Please note: the electrical connection of the unit must be carried out by a qualified electrician.

The unit is supplied with a flexible cord for connection to the mains supply.

NOTE: This unit must be earthed.

The mains power supply cable should be connected to a fixed wiring installation, via a fused isolator, in accordance with current IEE wiring regulations.

ELECTRICAL DETAILS: MRXBOX95-WH1-1Z	
Voltage:	230V 1ph 50Hz
Consumption:	WH1 - 1.3 Amp
Fuse rating:	3 Amp

Consultants Specification

TECHNICAL DATA

Fan Codes: MRXBOX95AB-WH1-1Z / MRXBOX95-WH1-1Z / MRXBOX95AB-WH1-1Z-OH / MRXBOX95-WH1-1Z-OH

Acoustically Enclosed Wall Mounted Multi-room Heat Recovery unit.

SPECIFICATION

The unit shall be fully insulated providing excellent thermal and acoustic characteristics and shall be complete with a multi plate counter flow high efficiency heat exchanger block, with a thermal efficiency of up to 95%. The heat exchanger shall be protected by G3 grade filters on fresh air inlet and system extract. The heat exchanger and filters shall be accessible via the front access panel, enabling quick and easy maintenance.

The unit shall have low energy, high efficiency EC fan/motor assemblies with sealed for life bearings, the impellers shall be backward curved centrifugal type. The motors shall be suitable of an ambient temperature of 40°C.

The unit shall be supplied complete with a condensate drip tray and 21.5mm drain connection.

The unit shall be suitable for 150mm diameter circular ducting.

The breakout noise level and power requirements shall be as detailed by the unit manufacturer and in accordance with the ventilation equipment schedule.

Units shall be one of MRXBOX95AB-WH1-1Z, MRXBOX95-WH1-1Z, MRXBOX95AB-WH1-1Z-OH, MRXBOX95-WH1-1Z-OH as manufactured by Nuair.

The unit shall be provided within a white pre-painted or coated steel acoustic enclosure lined with a minimum of 20mm class '0' acoustic foam insulation to reduce breakout noise.

In-duct noise shall be attenuated on Intake/Exhaust/Supply/Extract by means of a 4-way attenuator mounted within the enclosure and close coupled directly to the unit. Flexible duct connections shall be within the enclosure, pre-fitted between the attenuator section and the connection spigots on the top face of the enclosure. (Removing the need for flexible duct connectors outside of the unit which may cause breakout).

The MVHR unit and attenuator assembly shall be retained within the enclosure on a metal tray supported on turret type anti-vibration mounts of suitable deflection to ensure that vibration is not transmitted to the supporting structure.

All operational components of the MVHR unit shall be accessible via the front panel of the enclosure. The enclosure shall be supported on 3mm (minimum) prefabricated steel cantilever wall brackets or other suitable fabricated steel supporting frame.

The unit shall be offered with a 5 year warranty.

The unit complies with EU regulations No.1253/2014 and No.1254/2014.

OPERATION

The supply and extract ventilation unit shall be positioned as indicated on the drawings and shall be in accordance with the particular fan schedule in the specification. This unit is also available in Opposite Hand formatting.

The combined supply and extract with heat recovery unit, shall supply filtered fresh air to each of the habitable rooms and vitiated air shall be extracted from the wet areas e.g. bathroom, en-suite, w.c, kitchen, utility rooms, etc. The supply air shall be pre-heated by the warm extract air via the integrated counter-flow heat exchanger element. The extracted air shall also be filtered before it reaches the heat exchanger block.

The ventilation unit shall vary its speed and therefore the ventilation rate, as it receives signals from the switched live signal from light/remote switches or any ancillary sensors. When signals are received, the fan shall alter its speed to adjustable, normal and boost rates.

The unit shall have the facility to commission the supply and extract fans independently on minimum speed (continuous background ventilation), and boost speed, via inbuilt minimum and maximum speed adjustment. The fans shall have infinitely variable speed control.

INTEGRAL AUTOMATIC SUMMER BYPASS (MRXBOX95AB-WH1-1Z & MRXBOX95AB-WH1-1Z-OH only)

Including Automatic SUMMER BYPASS where intake and return air temperatures shall be measured so that supply air temperatures can be maximised during winter months and minimised as external ambient temperature rises. The Summer Bypass damper shall be opened by a wax actuator. Supply and Extract air shall be filtered irrespective of the bypass setting (open or closed).

Integral Humidity Sensor

The integral humidity sensor incorporated within the extract fan chamber will automatically boost both the extract and supply fan, to the commissioned boost speed, when the humidity level exceeds that set by the front panel mounted adjustment potentiometer.

CONTROL OPTIONS

All versions shall have the following functions integrally mounted within the fan unit on a purpose made PCB, all such components pre-wired and factory fitted by the manufacturer:

- Independent control of background supply and extract flow rates.
- Independent control of boost speed supply and extract flow rates.
- Integral fan failure indication.
- Integral S/L terminal for boost from remote switch, e.g. light switch, kitchen boost switch.
- Integral heat exchanger frost protection.
- Discreet daily run monitor.
- Integral humidistat.

OPTIONAL CONTROLS

MRXBOX95-RFI Remote fail indicator.
(or Volt Free contacts to allow failure indication to BMS).

MRXBOX95-PIR (Passive Infra Red)

A low voltage sensor which detects movement and activates system. Incorporates overrun timer and timer adjustments.

MRBOX95-HUM

A low voltage sensor which activates the system when the relative humidity level is above a set point. Incorporates overrun timer and relative humidity set-point level adjustment.

MRXBOX-VSC

An LCD controller for MVHR system with a 3.2" touch screen display. Can be surface or semi-recess mounted.

Bristol Harbourside: A First for Carbon Filters...

The award-winning Harbourside development of apartments in Bristol has grown with the addition of Invicta, a stylish new development of studio suites and apartments with private balconies and roof terraces.

Working for client Crest Nicholson, consultant Couch Perry Wilkes and contractor Gasworld, Nuaire manufactured and supplied the development with MVHR & MEV systems.

For the first time, this project utilises our newly launched Q-Aire Carbon Filters. These were used on two floors of one façade to prevent external levels of Nitrogen Dioxide from the nearby road from entering the apartment, ensuring compliance with planning conditions.

Whilst this impressive development may appear in an ideal setting on the waterfront, there are hidden dangers in the area. Considering the location, and the Council's enthusiasm to increase the tourist industry, it is not surprising that Ferries and local boat trips are a regular sight within the harbour. On top of these boats chugging away there are 3 active boat building companies, and some main roads within close proximity of this particular development.

Although Harbourside is no longer a heavily industrialised, working docks it would be foolish to ignore present day carbon emission problems. A Senior Technician of property developer Crest Nicholson shed some light on why they decided to employ our Q-Aire Carbon Filters within their residential construction...



“Nuaire’s carbon filter provided us with the opportunity to improve our ventilation systems by increasing the filtration of the air that entered the building. Its low profile design offered flexibility in installation; a benefit which we hope will prove equally as accommodating with regards to the maintenance of these units for the residents as all units can be accessed by home owners. Should another development require this level of pollutant filtration, I’m sure Nuaire’s Q-Aire Carbon Filter will prove a first class choice.”



NUAIRE LIMITED

Western Industrial Estate
Caerphilly
CF83 1NA

Residential product orders or enquiry:

Tel: +44 (0)29 2085 8500

Fax: +44 (0)29 2085 8555

info@nuaire.co.uk

After sales technical support:

Tel: +44(0)29 2085 8400

Fax: +44(0)29 2085 8555

info@nuaire.co.uk

www.nuaire.co.uk

 [@NuaireHomes](https://twitter.com/NuaireHomes)

As part of our policy of continuous product development Nuaire reserves the right to alter specifications without prior notice. Telephone calls may be recorded for quality and training purposes.