

One fan fits all - Kitchens, Utilities, Bathrooms, Toilets

Cl/SfB

(57.7)

1st edition



Lo-Carbon Quadra

Vent-Axia[®]
Lo-Carbon[™]

Vent-Axia Quadra

An Evolution in Residential Ventilation,
Designed especially for Social Housing

One fan fits all

Happy Installers

The fan that fits anywhere, is quick and easy to install with simple to replace components

Happy Landlords

The no maintenance fan that saves money and time, is risk free to specify and will keep tenants happy.

Happy Tenants

The fan that is discrete, quiet and cheap to operate providing them with a clean healthy home that does not cost the earth

Happy Environment

A long life fan producing less waste for landfill and lower energy use reducing our carbon footprint.



Quadra



Quadra exploded view



Fixed Chassis with a single 100mm spigot



Motor cassette - Plug in design allows for easy replacement

Probably the only fan you'll ever need!

Installers

- Easiest ever installation – saving time and money
- 100mm spigot – can replace any existing fan surface or recess mounted
- Parts can be replaced by non-Part P qualified staff
- Plug in motor assembly – Easy fit motor assembly preventing the need to rewire

Landlords

- One fan, any home, any use in any room – Quadra always fits for kitchens, utilities, bathrooms or toilets
- Safety first – IPX4 and speeds safe with open flued appliances it is Part F, J and L compliant
- Maintenance free - Filterless technology and self cleaning polymers means limited need for regular cleaning
- Intermittent or continuous – Building Regulation compliance to both systems and reducing reliance on trickle ventilators

Using our years of experience and listening to you, our customers, we believe that we have created the ideal domestic fan for use by Local Authorities and Housing Associations. By targeting its key features at the critical needs of our customers including landlords, installers, maintenance teams and the end users – the tenants we believe we have finally

found the perfect solution. The Quadra fan reduces time, money, energy and inconvenience for everyone that interacts with it. Whether you are a specifier, an Installer or a person who lives with Quadra in your home, we believe this fan is the best available.





Impeller - easily removable for cleaning



Front cover - Isolates the Impeller safely when cleaning

One fan for all your installations

Tenants

- LoWatt motors – With up to 80% less energy than a standard fan it saves money and reduces the carbon footprint
- Near silent - No intrusive running noise causing disturbance
- Small and neat – Less space and a flat front make it more discrete
- Fresh healthy home - Guaranteed Installed performance with flexible motor speed selection at installation

Environment

- Less waste – Casing designed to last the life of the building so less waste for Landfill
- Long life motor – 5 year warranty means fewer replacements
- Low energy use – LoWatt motors and computer designed impellers means up to 80% savings over traditional motors
- One size fits all - No components to dispose of at installation stage - again reducing wastage.



Vent-Axia Quadra

- allowing you to help the environment

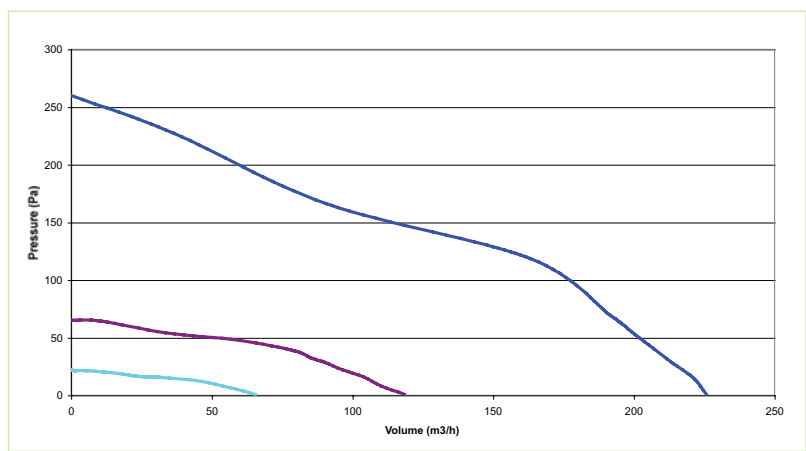

Performance points shown indicate the 3 available boost speed options for bathrooms, utility rooms and kitchens.

A choice of 3 trickle speeds at 6, 9 and 12 l/s also available at installation.

Adjustment for varying installations via Dip switches with the following options:

- Through the wall
- 1.5m ducting 1 x 90° bend
- 3.0m ducting 2 x 90° bends

Dimensions (mm)

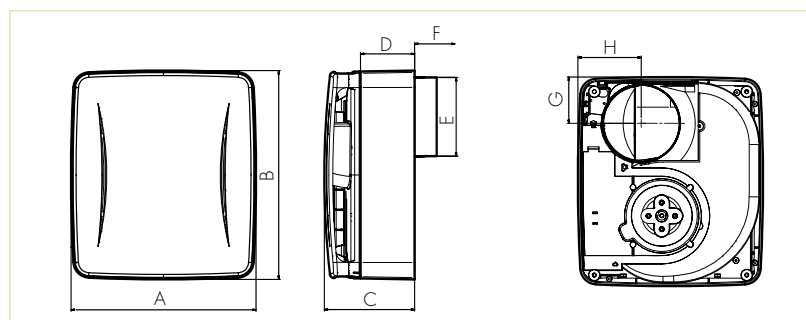

A	B	C	D	E	G	H	I
230	260	112	67	98	27	58	79

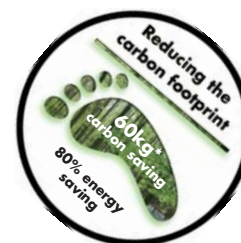

Performance

Model	Stock Ref Number	Extract Performance High		Extract Performance Low		Power High Watts	Power Low Watts	Sound dB(A) @ 3m	
		m³/h	l/s	m³/h	l/s			High	Low
Quadra TP	439251	216	60	22	6	35.7	3.8	50	20
Quadra HTP	439181	216	60	22	6	35.7	3.8	50	20
Quadra TM	439253	216	60	22	6	35.7	3.8	50	20
Accessories	Stock Ref Number								
Flush Mounting Kit	439256								
Filter	439927								

Tested at 240V 50Hz in through the wall configuration



By Appointment to H.M. The Queen
Suppliers of Unit Ventilation Equipment
Vent-Axia, Crawley, West Sussex

Vent-Axia®

VENT-AXIA CONTACT NUMBERS

Free technical, installation and sales advice is available

Sales Centre:

Domestic & Commercial

Sales Tel: 0844 856 0590
Sales Fax: 01293 565169
Tech Support Tel: 0844 856 0594
Tech Support Fax: 01293 539209

Industrial

Sales Tel: 0844 856 0591
Sales Fax: 01293 534898
Tech Support Tel: 0844 856 0595
Tech Support Fax: 01293 455197
Web: www.vent-axia.com
Email: info@vent-axia.com

Supply & Service

All sales made by Vent-Axia Limited are made only upon the terms of the Company's Conditions of Sale, a copy of which may be obtained on request. As part of the policy of continuous product improvement Vent-Axia reserves the right to alter specifications without notice.