

Centrif Duo & Centrif Duo Plus

Installation and Wiring Instructions

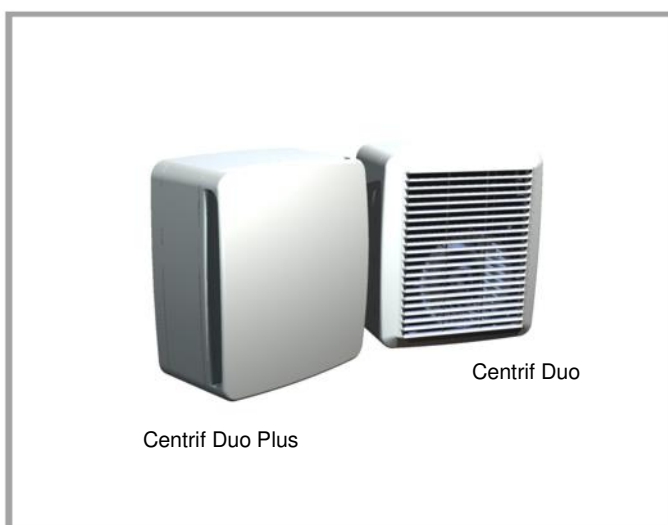

Stock Ref. N°

Centrif Duo P 25 61 20D
Centrif Duo T 25 62 20D
Centrif Duo DP 25 63 20D
Centrif Duo HTP 25 64 20D

Centrif Duo Plus P 43 16 13B
Centrif Duo Plus T 43 16 14B
Centrif Duo Plus DP 43 16 15B
Centrif Duo Plus HTP 43 16 16B

Vent-Axia®

PLEASE READ INSTRUCTIONS IN CONJUNCTION WITH ILLUSTRATIONS.
PLEASE SAVE THESE INSTRUCTIONS.



Centrif Duo and Centrif Duo Plus

Features	P	T	DP	HTP
Surface mountable	•	•	•	•
Flush mountable with accessory kit (available separately)	•	•	•	•
Washable filter (available separately for Centrif Duo Plus)	•	•	•	•
Pullcord	•		•	•
Trickle speed	•	•	•	•
LS connection (to boost from a remote switch from off or trickle speed).	•	•	•	•
Two boost speed options available (selectable during installation)	•	•	•	•
Adjustable timer overrun (1-30 mins approx)		•		•
Adjustable humidity sensor (default 75%RH approx)				•



**IMPORTANT:
READ THESE INSTRUCTIONS
BEFORE COMMENCING THE
INSTALLATION**

DO NOT install this product in areas where the following may be present or occur:

- Excessive oil or a grease laden atmosphere.
- Corrosive or flammable gases, liquids or vapours.
- Ambient temperatures higher than 40°C or less than -5°C.
- Possible obstructions which would hinder the access or removal of the fan.

SAFETY AND GUIDANCE NOTES

- A.** All wiring to be in accordance with the current I.E.E. Regulations, or the appropriate standards of your country and **MUST** be installed by a suitably qualified person.
- B.** The fan should be provided with a local isolator switch capable of disconnecting all poles, having a contact separation of at least 3mm.
- C.** Ensure that the mains supply (voltage, frequency, and phase) complies with the rating label.
- D.** The fan should only be used in conjunction with the appropriate Vent-Axia products.
- E.** It is recommended that the connection to the fan connector terminals is made with flexible cable.
- F.** When the fan is used to remove air from a room containing a fuel-burning appliance, ensure that the air replacement is adequate for both the fan and the fuel-burning appliance.
- G.** Precautions must be taken to avoid the backflow of gases into the room from the open flue of gas or other fuel burning appliances
- H.** The fan should not be used where it is liable to be subject to direct water spray for prolonged periods of time.
- I.** Where ducted fans are used to handle moisture-laden air, a condensation trap should be fitted. Horizontal ducts should be arranged to slope slightly downwards away from the fan.
- J.** This appliance is not intended for use by persons (including children) with reduced physical, sensory or mental capabilities, or lack of experience and knowledge, unless

they have been given supervision or instruction concerning use of the appliance by a person responsible for their safety.

- K.** Children should be supervised to ensure that they do not play with the appliance.

DESCRIPTION

As standard, the Centrif Duo and Centrif Duo Plus are suitable for panel/wall installations, surface mounting, either in a horizontal or vertical plane. A Flush Mount Kit (439256) is available as an accessory. Ø100mm ducting (flexible or rigid) can be attached providing rear exit as standard or side exit with the Flush Mount Kit. Adaptors for rectangular ducting can be used. For wall installations a Wall Kit (25 41 02 White / 25 41 00 Brown) can be used. Please see our catalogue or web site (www.vent-axia.com) for more information on ducting and termination options.

A. INSTALLATION

A Backdraught Shutter Assembly is supplied. It is packed inside the product during transport. It is designed to block the duct when the fan is off in order to prevent cold draughts from outside entering the building. To use it, push it on to the end of the exhaust Spigot (*fig.1*) with the hinges on the flaps vertical. It is not required when the fan is set up to run continuously.

SURFACE MOUNTING (PANEL/CEILING)

1. Remove the Front Cover Assembly by slackening the two screws by two turns (*fig.2.*) Lift the front assembly away from the bottom edge first, then the top edge.
2. Cut a Ø105mm hole, then suitable screw holes in the panel, ensuring that there is sufficient space for the product to be installed and that the filter (sold separately for the Centrif Duo Plus) can be removed for maintenance. Either the cardboard fitment or the fan chassis can be used as a template. The Spigot can be removed temporarily to make it easier. (*Fig 1 & 3*).
3. Set-up the appropriate speed selection and other features as outlined in **Section B SETUP.**
4. Remove the small Terminal Block Cover in the top right corner (*fig 3*).
5. Attach the ducting to the Spigot and locate the fan into the hole in the panel. Feed the wiring through the hole in the Chassis next to the Terminal Block as you do so. (*fig. 4*)
6. Secure into position using appropriate fixtures.
7. Select and follow the appropriate wiring diagram in **Section C WIRING.**
8. Replace the little Terminal Block Cover over the Terminal Block (*fig.4*).
9. Ensure the Impeller rotates freely (*fig.3*).
10. Replace the Front Cover Assembly and tighten the two screws (*fig.2.*).
11. Make sure that all covers are on correctly to ensure the optimum performance and water ingress protection of the fan.
12. Switch the mains power supply on and check the fan is operating correctly.

SURFACE MOUNTING (WALL)

For through-the-wall installations, a Wall Kit (25 41 02 White / 25 41 00 Brown) can be used.

1. Remove the Front Cover Assembly by slackening the two screws by two turns (*fig.2.*) Lift the Front Cover Assembly away from the bottom edge first, then the top edge.
2. Cut a Ø115mm hole through the wall, ensuring that there is sufficient space for the product to be installed and that the Filter (*fig.3*) can be removed for maintenance.
3. Insert the wall sleeve with the larger diameter sleeve on the room-side and cement the ends into position flush with the wall faces. The wall sleeve should be angled downwards, away from the fan, to allow any condensation to drain to the outside.
4. Outside Grille: Using the Grille's back plate as a template, mark the fixing hole centres on the wall. Drill and plug the wall and fix the Grille into position. Ensure the louvres are pointing downwards.
5. Set-up the appropriate speed selection and other features as outlined in **Section B SETUP.**
6. Remove the little Terminal Block Cover in the top right corner (*fig 3*).
7. Using the fan chassis as a template, carefully sliding the Spigot into the Wall Liner, mark the fixing hole centres on the wall. Alternatively, the cardboard fitment can be used as a template.
8. Drill and plug the wall using the fixings provided.
9. Feed the wiring through the hole near the Terminal Block and secure the fan into position using the screws provided.
10. Select and follow the appropriate wiring diagram in **Section C WIRING.**
11. Replace the Terminal Block Cover (*fig.4*).
12. Ensure the Impeller (*fig.3*) rotates freely.
13. Replace the Front Cover Assembly and tighten the two screws (*fig.2*).

14. Make sure that all covers are on correctly to ensure the optimum performance and water ingress protection of the fan.
15. Switch the mains power supply on and check the fan is operating correctly.

FLUSH MOUNTING (PANEL/CEILING)

A Flush Mount Kit (439256) is required.

1. Remove the Front Cover Assembly by slackening two screws by two turns (*fig.2*). Lift the front assembly slowly from the bottom edge first, then the top edge.
2. Mark and cut a rectangular hole 222mm (w) x 253mm (h) through the panel ensuring that there is sufficient space for the product to be installed and that the Filter (*fig.3*) can be removed for maintenance. **IMPORTANT: Be careful to avoid joists and hidden pipes or cables.**
3. Remove the Back Box pieces by removing the four screws (*fig 5*). Replace it with the Frame from the Flush Mount Kit.
4. Pass each of the long Panel Clip Screws (*fig.6*) supplied in the kit fully through the flange of the Chassis and screw in to the four Panel Clips allowing enough space between the clip and the flange for the thickness of the panel (so that the clips can spring open behind the panel).
5. Set-up the appropriate speed selection and other features as outlined in **Section B SETUP.**
6. Remove the Terminal Block Cover in the top right corner (*fig 3*).
7. Attach the ducting to the Spigot and locate the fan into the hole in the panel, ensuring the cable is fed into the fan Chassis and the Panel Clips spring out behind the panel.
8. Secure into position by carefully tightening the four Panel Clip Screws. **IMPORTANT: If power tools are used, set them to the minimum torque setting or preferably use a manual screwdriver. Do not over tighten.**
9. Select and follow the appropriate wiring diagram in **Section C WIRING.**
10. Replace the Terminal Block Cover.
11. Ensure the Impeller rotates freely (*fig.3*).
12. Replace the Front Cover Assembly and tighten the two screws (*fig.2*).
13. Make sure that all covers are on correctly to ensure the optimum performance and water ingress protection of the fan.
14. Switch the mains power supply on and check the fan is operating correctly.

B. SETUP



WARNING: THE FAN AND ANCILLARY CONTROL EQUIPMENT MUST BE ISOLATED FROM THE POWER SUPPLY DURING INSTALLATION OR MAINTENANCE.

TO ACCESS THE SPEED CONTROLS/PCB, REMOVE THE 2 SCREWS HOLDING THE PCB COVER IN PLACE (SEE FIG 4).

1. SELECTING THE CONSTANT TRICKLE (with Boost) OPTION

All models have the ability to have a constant trickle speed with an option to boost if required. To enable constant trickle, please refer to fig 7 and below:

- i) **P model:** Link terminals 5 and 6.
- ii) **DP model:** Pull pullcord until in the trickle speed has been selected. If you want to just use the LS to switch the DP model between trickle and boost, first set the fan running to trickle speed with the pull cord, then remove the pull cord string.
- iii) **T and HTP models:** Move dip switch 4 into the ON position.

2. SELECTING THE BOOST SPEED.

All models can boost to a higher speed via LS connection or Pullcord (pullcord not available on T model). The HTP model can boost to different speeds for Timer (LS) and Automatic Humidistat functions.

- i) P Model: Link terminal 4 to one of the following:
 - a. Terminal 1 = Low speed (same as trickle speed)
 - b. Terminal 2 = Medium (Utility) speed
 - c. Terminal 3 = High (Kitchen) speed
- ii) DP model: Link terminal 3 to one of the following:
 - a. Terminal 1 = Medium (Utility) speed
 - b. Terminal 2 = High (Kitchen) speed
- iii) T model: Move one of the following dip switches into the ON position.
 - a. Dip switch 1 = Low speed (same as trickle speed)
 - b. Dip switch 2 = Medium (Utility) speed
 - c. Dip switch 3 = High (Kitchen) speed

- iv) HTP model: The HTP model has two boost speed options, one speed option for the Timer function (via LS) or pullcord and another speed selection for the Humidistat function. Move one dip switch into the ON position for LS/pullcord and one for Humidity speed selection. It is recommended for both Kitchen and Utility room installations to set the Humidity Boost speed to Medium (utility). This will ensure the room is kept dry but reduce the noise from the fan.
 - a. Dip switch 5 = Humidity Boost Low speed (same as trickle speed)
 - b. Dip switch 6 = Humidity Boost Medium (Utility) speed
 - c. Dip switch 7 = Humidity Boost High (Kitchen) speed
 - d. Dip switch 1 = LS/Pullcord Boost Low speed (same as trickle speed)
 - e. Dip switch 2 = LS/Pullcord Boost Medium (Utility) speed
 - f. Dip switch 3 = LS/Pullcord Boost High (Kitchen)

3. TIMER ADJUSTMENT (T and HTP models only)

The overrun time period is factory set to about 15 minutes. The overrun time period may be adjusted from about 1-30 minutes by altering the lower adjuster of the two on the control PCB (*fig.4 & 7*).

- i. To REDUCE the operating time, turn the timer adjuster ANTI-CLOCKWISE.
- ii. To INCREASE the operating time, turn the timer adjuster CLOCKWISE.

4. RELATIVE HUMIDITY ADJUSTMENT (HTP model only)

NOTE:- On installation it is possible that the humidity controller will run continuously until it has acclimatized to the environment.

The fan's relative humidity (RH) set-point is factory set to switch the fan on at about 75%RH. This set point can be raised or lowered by altering the upper adjuster of the two on the PCB (*fig.4 & 7*).

- i. To LOWER the set-point, turn the humidity adjuster (*fig.4 & 7*) CLOCKWISE. This makes the fan more sensitive to RH, i.e. the fan will come on at a lower RH.
- ii. To RAISE the set-point, turn the humidity adjuster (*fig.4 & 7*) ANTI-CLOCKWISE. This makes the fan less sensitive to RH, i.e. the fan will come on at a higher RH.

The fan will continue to run at boost after the RH has dropped below the set point for the time period set by the timer adjustment (see 3. TIMER ADJUSTMENT, above)

C. WIRING.



WARNING: THE FAN AND ANCILLARY CONTROL EQUIPMENT MUST BE ISOLATED FROM THE POWER SUPPLY DURING INSTALLATION OR MAINTENANCE.

Use 0.75mm² cable

1. Select and follow the appropriate wiring diagram (*fig. 9 or 10*).
2. Use the Cable Clamp provided (*fig.4*).
3. Check all connections have been made correctly and ensure all terminal connections are securely fastened.

D. SERVICING AND MAINTENANCE.



WARNING: THE FAN AND ANCILLARY CONTROL EQUIPMENT MUST BE ISOLATED FROM THE POWER SUPPLY DURING SERVICING AND MAINTENANCE.

1. At intervals appropriate to the installation, the fan should be inspected and cleaned to ensure there is no build up of dirt or other deposits.
2. If fitted, remove the Filter (*fig.2 & 3*) and wash it and the front cover assembly in warm soapy water. Dry them before replacing.
3. Wipe the inlets and front face with a damp (not dripping wet) cloth until clean.
4. Replace the filter.
5. Turn the power to the fan back on.

The fan has sealed for life bearings, which do not require lubrication.

Fig.1.

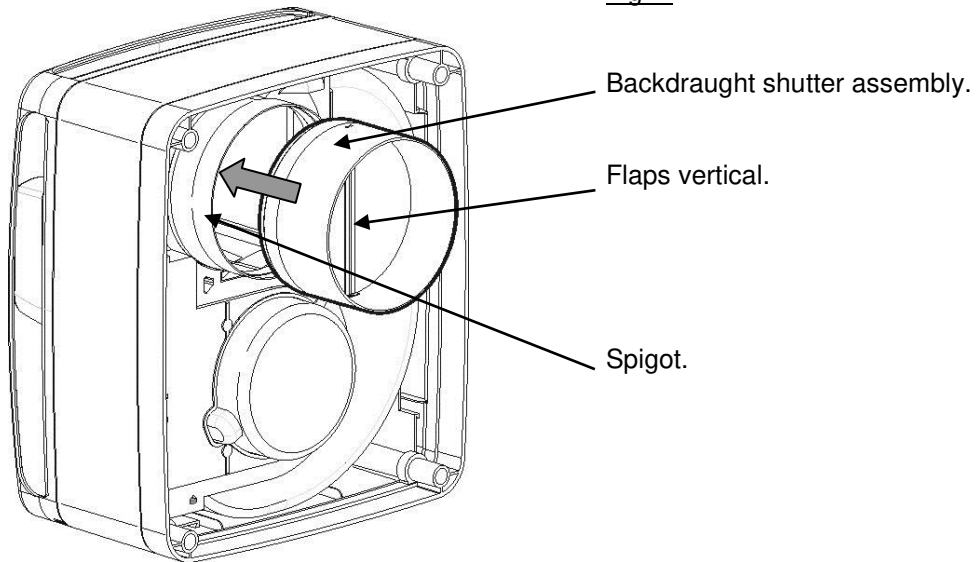
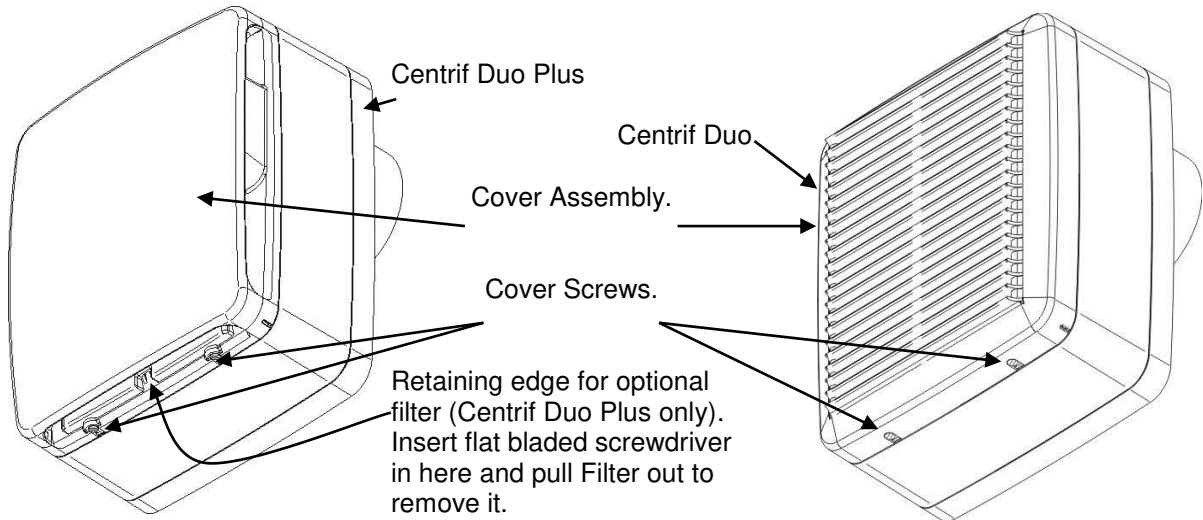

Fig.2.



Centrif Duo Plus shown

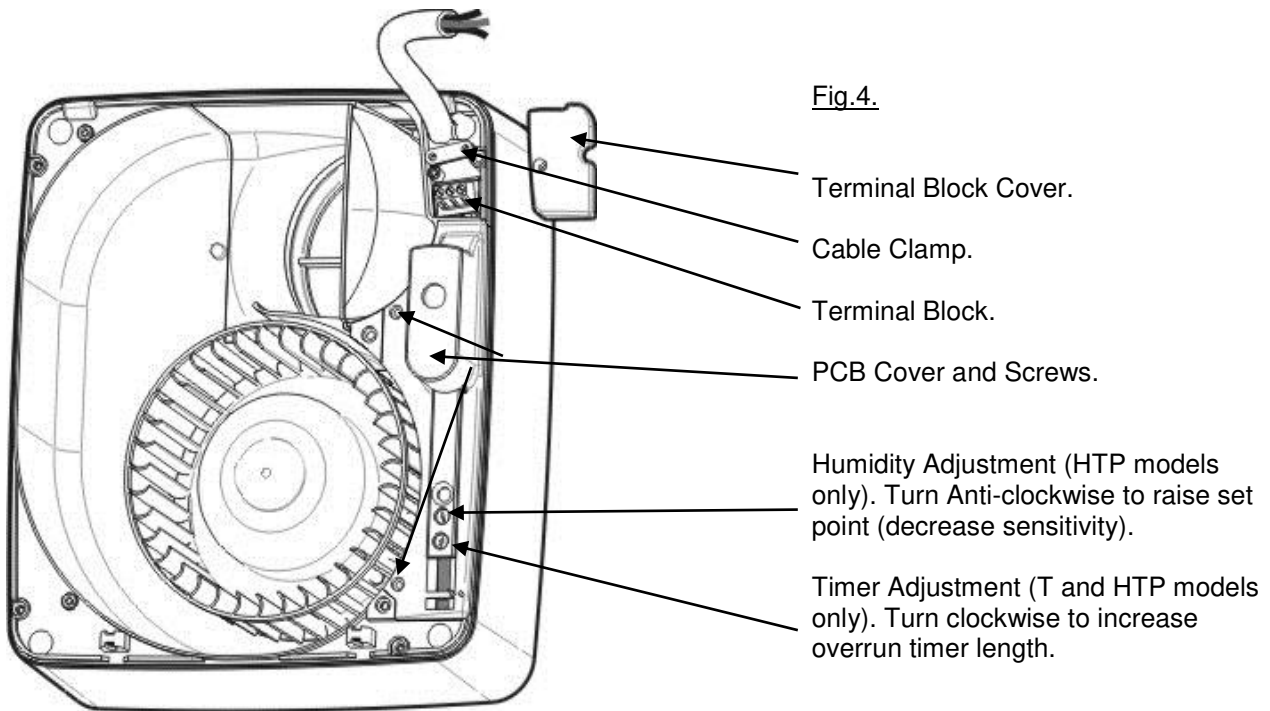
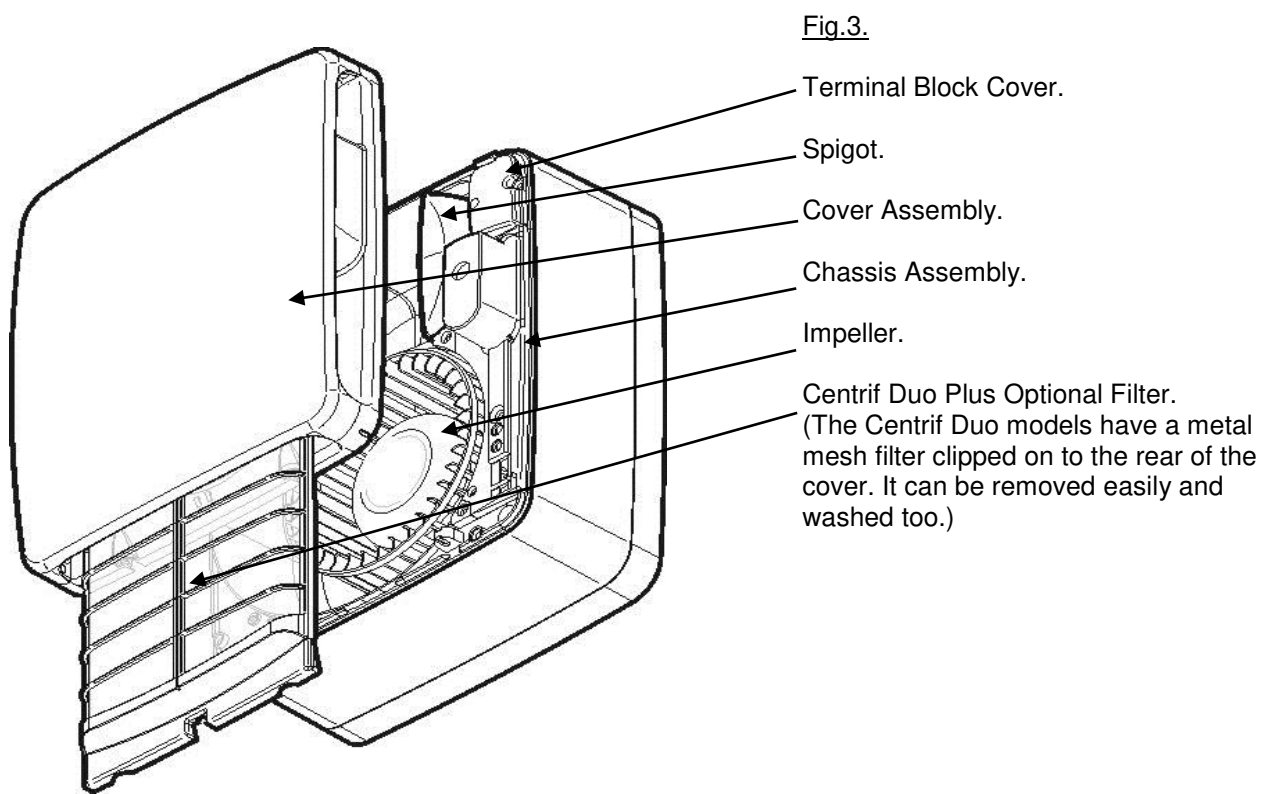

Fig.5.

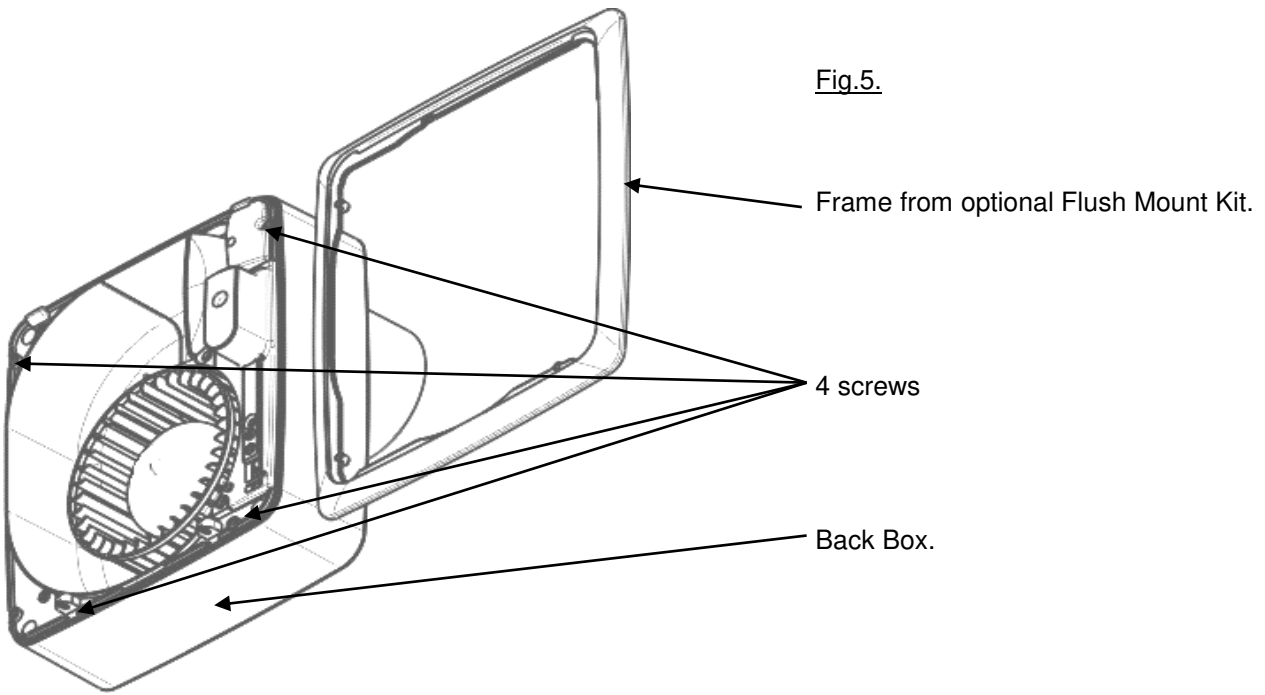

Fig.6.

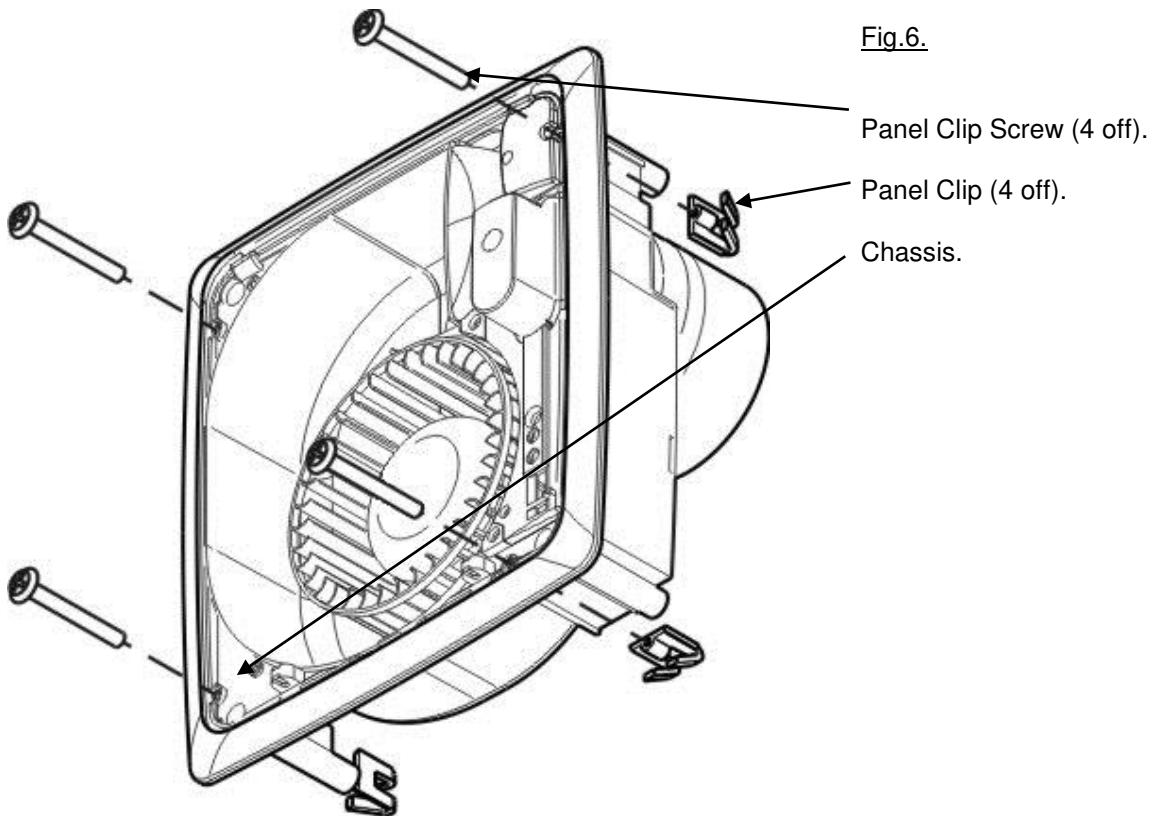
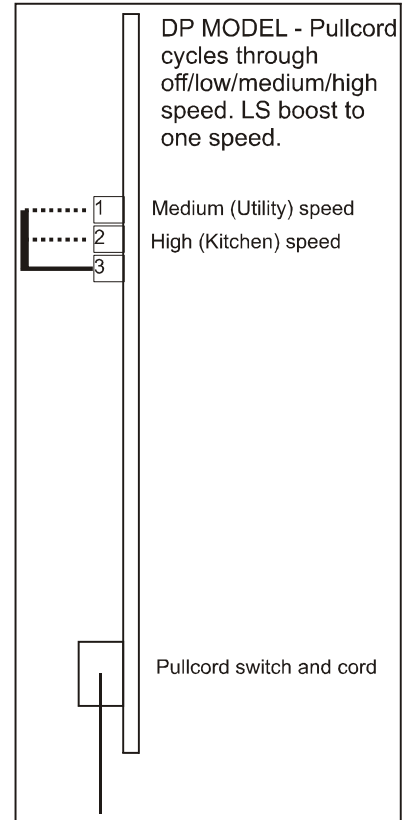
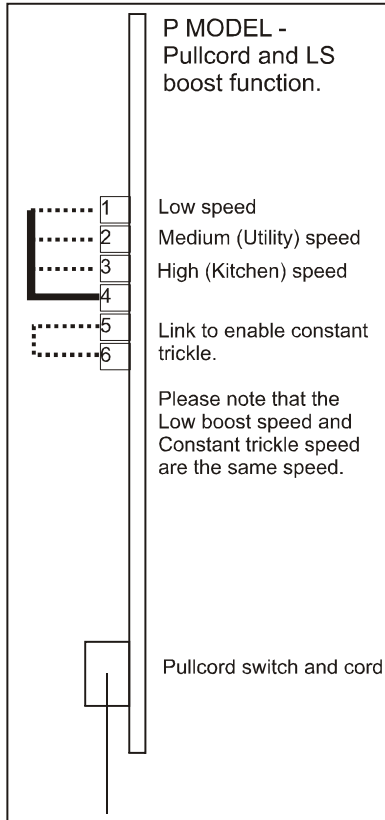
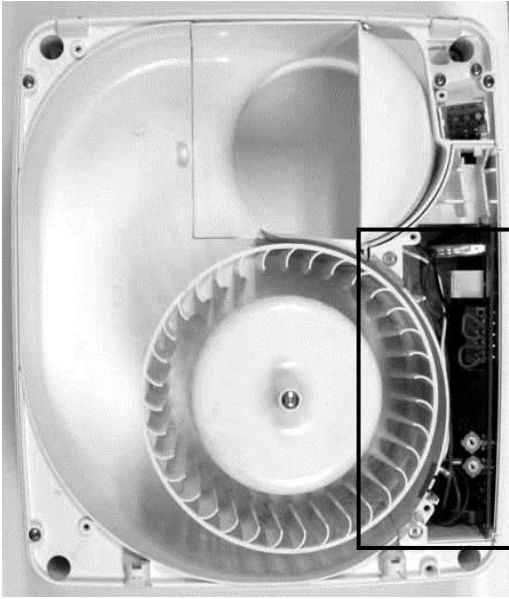

Fig 7. Setup



WARNING: THE FAN AND ANCILLARY CONTROL EQUIPMENT MUST BE ISOLATED FROM THE POWER SUPPLY DURING INSTALLATION OR MAINTENANCE.
 TO ACCESS THE SPEED CONTROLS/PCB, REMOVE THE TWO SCREWS HOLDING THE PCB COVER IN PLACE (SEE FIG 4).

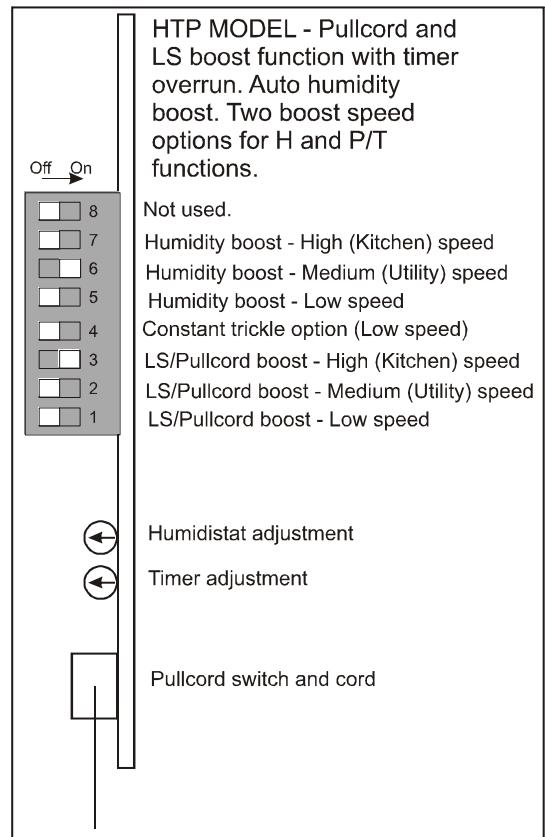
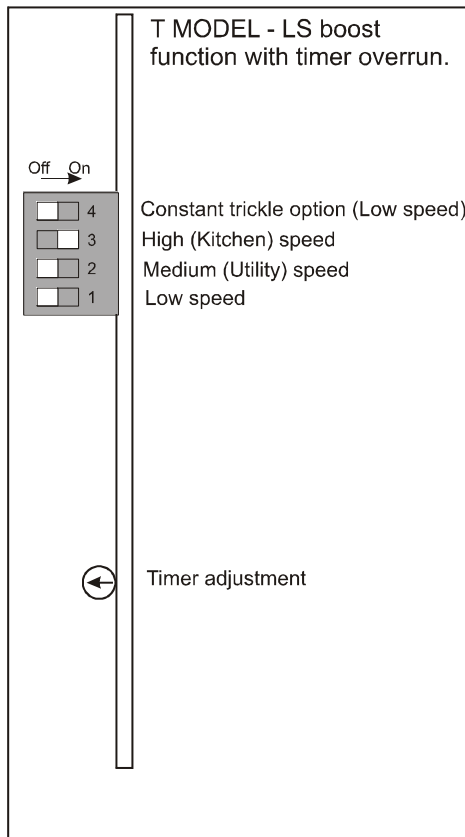

Fig 8. Siting of the fan.

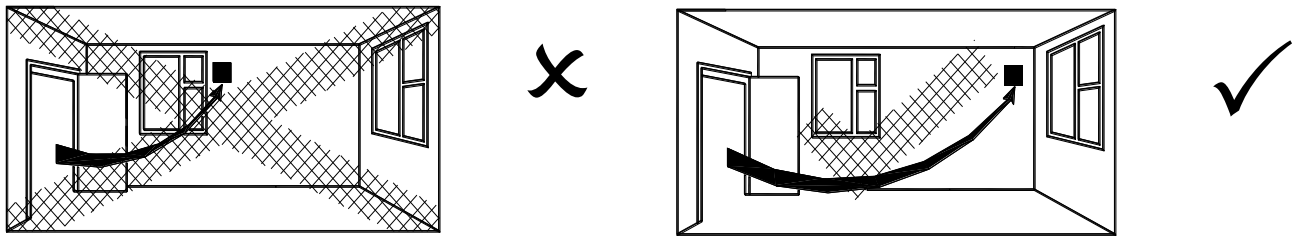

Fig 9. Wiring diagram without LS connection.

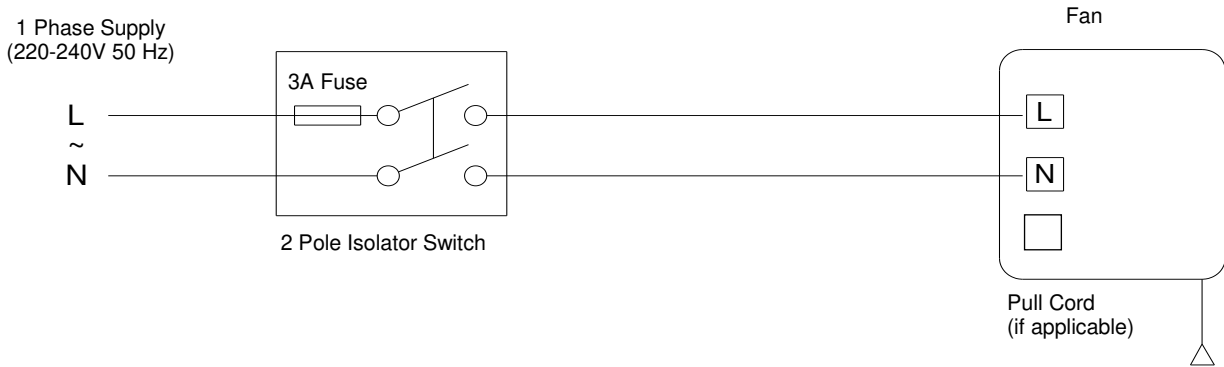
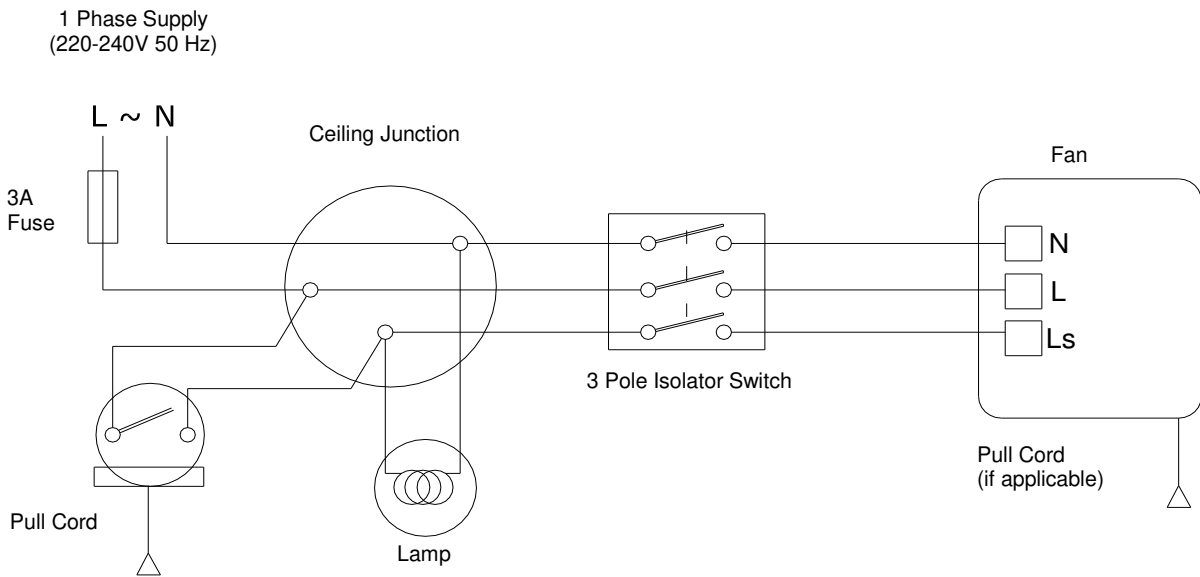

Fig 10. Wiring diagram with LS connection.



Other accessories, like pullcords, PIR sensors or humidistats, can be fitted in line with the mains live connection (L) in order to turn the fan on or off.

PRODUCT FICHE

For Residential Ventilation Units (Complying Commission Delegated Regulation (EU)
No 1254/2014)

Name:	Vent-Axia	Vent-Axia	Vent-Axia	Vent-Axia
Model ID (Stock Ref.) :	Centrif Duo P - 256120	Centrif Duo T - 256220	Centrif Duo DP - 256320	Centrif Duo HTP - 256420
SEC Class	D	D	D	D
SEC Value ('Average')	26.23	26.23	26.23	26.23
SEC Value ('Warm')	11.86	11.86	11.86	11.86
SEC Value ('Cold')	51.31	51.31	51.31	51.31
Label Required? (Yes/No=Out of scope)	Yes	Yes	Yes	Yes
Declared as: RVU or NRUVU/UVU or BVU	RVU-UVU	RVU-UVU	RVU-UVU	RVU-UVU
Speed Drive	2-Speed	2-Speed	2-Speed	2-Speed
Type HRS (Recuperative, Regenerative, None)	None	None	None	None
Thermal Eff: [(%), NA(if none)]	N/A	N/A	N/A	N/A
Max. Flow Rate (m3/h)	219.60	219.60	219.60	219.60
Max. Power Input (W): (@Max.Flow Rate)	60.00	60.00	60.00	60.00
LWA: Sound Power Level (dB)	60.42	60.42	60.42	60.42
Ref. Flow Rate (m3/s)	0.04	0.04	0.04	0.04
Ref. Pressure Diff. (Pa)	135.00	135.00	135.00	135.00
SPI [W/(m3/h)]	0.27	0.27	0.27	0.27
Control Factor & Control Typology: (CTRL/ Typology)				
Control Factor; CTRL	0.65	0.65	0.65	0.65
Control Typology	Local Demand Control	Timer control	Local Demand Control	Local Demand Control
Declared: -Max Internal & External Leakage Rates(%) for BVUs or carry over (for regenerative heat exchangers only), -&Ext. Leakage Rates (%) for Ducted UVUs;	N/A	N/A	N/A	N/A
Mixing Rate of Non-Ducted BVUs not intended to be equipped with one duct connection on either supply or extract air side;	N/A	N/A	N/A	N/A
Position and description of visual filter warning for RVUs intended for use with filters, including text pointing out the importance of regular filter changes for performance and energy efficiency of the unit	N/A	N/A	N/A	N/A
For UVUs (Instructions Install Regulated Supply/Extract Grilles Façade)	In F&W	In F&W	In F&W	In F&W
Internet Address (for Disassembly Instructions)	www.vent-axia.com	www.vent-axia.com	www.vent-axia.com	www.vent-axia.com
Sensitivity p. Variation@+20/-20 Pa: (for Non-Ducted Vus)	N/A	N/A	N/A	N/A
Air Tightness-ID/OD-(m3/h) (for Non-Ducted Vus)	N/A	N/A	N/A	N/A
Annual Electricity Consumption: AEC (kWh/a)	2.19	2.19	2.19	2.19
Annual Heating Saved: AHS (kWh/a)				
AHS: Average	26.23	26.23	26.23	26.23
AHS: Warm	11.86	11.86	11.86	11.86
AHS: Cold	51.31	51.31	51.31	51.31

Name:	Vent-Axia	Vent-Axia	Vent-Axia	Vent-Axia
Model ID (Stock Ref.) :	Centrif Duo Plus P - 431613	Centrif Duo Plus T - 431614	Centrif Duo Plus DP - 431615	Centrif Duo Plus HTP - 431616
SEC Class	D	D	D	D
SEC Value ('Average')	26.23	26.23	26.23	26.23
SEC Value ('Warm')	11.86	11.86	11.86	11.86
SEC Value ('Cold')	51.31	51.31	51.31	51.31
Label Required? (Yes/No=Out of scope)	Yes	Yes	Yes	Yes
Declared as: RVU or NRVU/UVU or BVU	RVU-UVU	RVU-UVU	RVU-UVU	RVU-UVU
Speed Drive	2-Speed	2-Speed	2-Speed	2-Speed
Type HRS (Recuperative, Regenerative, None)	None	None	None	None
Thermal Eff: [(%), NA(if none)]	N/A	N/A	N/A	N/A
Max. Flow Rate (m3/h)	219.60	219.60	219.60	219.60
Max. Power Input (W): (@Max.Flow Rate)	60.00	60.00	60.00	60.00
LWA: Sound Power Level (dB)	60.42	60.42	60.42	60.42
Ref. Flow Rate (m3/s)	0.04	0.04	0.04	0.04
Ref. Pressure Diff. (Pa)	135.00	135.00	135.00	135.00
SPI [W/(m3/h)]	0.27	0.27	0.27	0.27
Control Factor & Control Typology: (CTRL/ Typology)				
Control Factor; CTRL	0.65	0.65	0.65	0.65
Control Typology	Local Demand Control	Timer control	Timer control	Local Demand Control
Declared: -Max Internal & External Leakage Rates(%) for BVUs or carry over (for regenerative heat exchangers only), -&Ext. Leakage Rates (%) for Ducted UVUs;	N/A	N/A	N/A	N/A
Mixing Rate of Non-Ducted BVUs not intended to be equipped with one duct connection on either supply or extract air side;	N/A	N/A	N/A	N/A
Filter Warning (RVU)	N/A	N/A	N/A	N/A
For UVUs (Instructions Install Regulated Supply/Extract Grilles Façade)	In F&W	In F&W	In F&W	In F&W
Internet Address (for Disassembly Instructions)	www.vent- axia.com	www.vent- axia.com	www.vent- axia.com	www.vent- axia.com
Sensitivity p. Variation@+20/-20 Pa: (for Non-Ducted Vus)	N/A	N/A	N/A	N/A
Air Tightness-ID/OD-(m3/h) (for Non- Ducted Vus)	N/A	N/A	N/A	N/A
Annual Electricity Consumption: AEC (kWh/a)	2.19	2.19	2.19	2.19
Annual Heating Saved: AHS (kWh/a)				
AHS: Average	26.23	26.23	26.23	26.23
AHS: Warm	11.86	11.86	11.86	11.86
AHS: Cold	51.31	51.31	51.31	51.31

The **Vent-Axia** Guarantee

Applicable only to products installed and used in the United Kingdom. For details of guarantee outside the United Kingdom contact your local supplier.

Vent-Axia guarantees its products for two years from date of purchase against faulty material or workmanship. In the event of any part being found to be defective, the product will be repaired, or at the Company's option replaced, without charge, provided that the product:-

- Has been installed and used in accordance with the instructions given with each unit.
- Has not been connected to an unsuitable electricity supply. (The correct electricity supply voltage is shown on the product rating label attached to the unit).
- Has not been subjected to misuse, neglect or damage.
- Has not been modified or repaired by any person not authorised by the company.

IF CLAIMING UNDER TERMS OF GUARANTEE

Please return the complete product, carriage paid to your original supplier or nearest Vent-Axia Centre, by post or personal visit. Please ensure that it is adequately packed and accompanied by a letter clearly marked "Guarantee Claim" stating the nature of the fault and providing evidence of date and source of purchase.

The guarantee is offered to you as an extra benefit, and does not effect your legal rights

Vent-Axia

Head Office: Fleming Way, Crawley, West Sussex, RH10 9YX. Tel: 01293 526062 Fax: 01293 551188

UK NATIONAL CALL CENTRE, Newton Road, Crawley, West Sussex, RH10 9JA

SALES ENQUIRIES: Tel: 0844 8560590 Fax: 01293 565169

TECHNICAL SUPPORT: Tel: 0844 8560594 Fax: 01293 539209

Web:-www.vent-axia.com Email:- info@vent-axia.com

As part of the policy of continuous product improvement Vent-Axia reserves the right to alter specifications without notice.