

Performance Chart

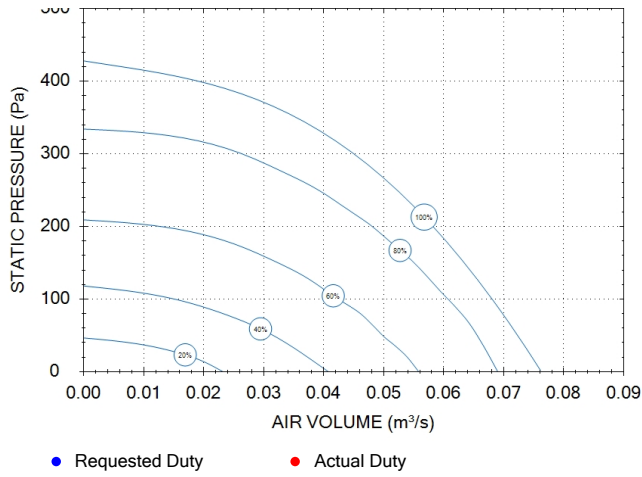

443319L

Tech Ref File:
 Stock Reference: 443319L
 Product Description: Lo-Carbon Sentinel Kinetic BH (Left)
 Product Type: Ventilation
 Product Range: Heat Recovery
 Impeller: Forward Curved
 Casing: ABS
 Speed: Variable
 Airstream Temperature: -20°C to 45°C
 dBA: 39
 Specific Fan Power & dB(A) shown are at duty point.

Warranty: Up to 5 years

Electrical Information

Supply Voltage: 220-240V/1/50Hz
 Motor IP Rating: IP22
 S.T.O.P. Protection: Yes
 Speed Controllable: In Built

Acoustic Information

	63	125	250	500	1k	2k	4k	8k	Total	dBA@3m
Inlet	66	63	60	56	51	44	36	32	69	37
Outlet	70	75	73	66	63	59	53	50	78	49
Breakout	59	55	56	55	56	53	47	41	64	39

Sound Power Level Spectra dB (re 10^{-12} Watts)

For ducted units, sound power is given as In Duct with end reflections added.

Stated dB(A) levels at 3m with spherical propagation at a reference level of 2×10^{-12} Pa

Optional Accessories

Part No	Description
433257	SENTINEL TEMP/CO2 SENSOR
442030	ISOLATOR RELAY CONTROLLER
563532	Ecotronic Humidity Sensor
563550	Ambient Response Humidity Sensor
563506	AIR QUALITY SENSOR TYPE 3

Part No	Description
459623	VISIONEX MK3 240V PIR
437320	TRICKLE/BOOST SWITCH SS
455213	TRICKLE/BOOST SWITCH ASSY

Dimensions

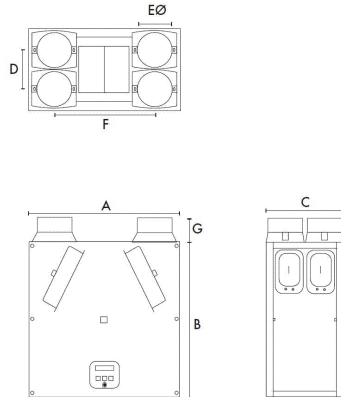

A	B	C	D	EØ	F	G	Weight
550	550	285	140	125	360	90	15

Dimensions shown in mm
 Weights in kg

SAP Appendix Q 2012

	Thermal Efficiency (%)	SFP (W/l/s)
K+1	90	0.61
K+2	90	0.74
K+3	90	0.95
K+4	90	1.19
K+5		