



NEW



MVHR - WHHR Mini DC

- with or without summer bypass
- energy efficient EC motor
- efficient, low energy solution to controlling condensation and pollution
- provides low level continuous ventilation in a kitchen and 1 other wet room
- up to 83% heat exchange efficiency
- variable choice of low (trickle) and boost speed at installation
- very compact 230 x 400mm square
- for cupboard, loft or ceiling void
- low noise levels and running costs
- compliant with Building Regulations Parts L1 2013 and F 2013
- manufactured in UK to ISO 9001
- with electronic control "Plus"

AVAILABLE NOW FROM

i-sells.co.uk



Unit 6 Chiltonian
203 Manor Lane
Lee, London
SE12 0TX

SALES: 0208 463 9696
FAX: 08456 44 60 02
EMAIL: sales@i-sells.co.uk
WEB: http://www.i-sells.co.uk



WHHR Mini DC

GENERAL FEATURES

- for 1 or 2 bedroom apartments, hotel rooms, student accommodation, extra care facilities etc
- Up to 29.8 litre/sec at 50Pa - max 34 litre/sec capacity
- up to 83% of heat recovered from extracted air
- easy and economical installation and maintenance
- ideal for fitting into voids, false ceilings or cupboards (bottom access only)
- variable low (trickle) and boost options
- boost speed triggered by a switched live connection from:
 - a light switch (if more than one light switch is used, **each one must be a double pole switch**)
 - DRH240 (dynamic remote humidistat)
 - PIRFF (passive infra red)
 - THM (thermostat)
 - a remote switch/pull cord
- low noise levels - below 20dB(A)
- low running costs
- extra security - no need to open windows
- 2 year warranty

MODELS AVAILABLE:

- WHHR Mini L - left drain
- WHHR Mini R - right drain
- WHHR Mini LH - humidistat, left drain
- WHHR Mini RH - humidistat, right drain
- WHHR Mini LB - bypass, left drain
- WHHR Mini RB - bypass, right drain
- WHHR Mini LBH - bypass, humidistat, left drain
- WHHR Mini RBH - bypass, humidistat, right drain

TECHNICAL FEATURES

- compact unit
- casing from steel sheet - epoxy paint finish
- thermo-acoustic lining
- low energy EC brushless motor
- single width, single inlet, direct drive, backward curved impellers
- operates in temperature up to 60°C
- uses standard, disposable G3 filters
- counter flow heat exchanger
- manufactured in UK to ISO 9001

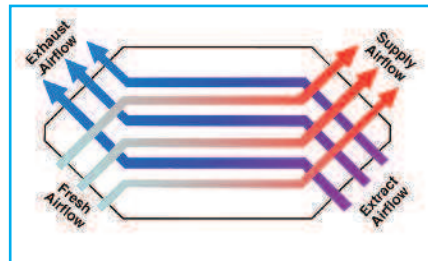

COMPLIES WITH

- Part L1 2013 of Building Regulations for enhanced energy saving capability
- Part F 2013 of Building Regulations for reliable, efficient ventilation
- EU RoHS Directive Compliant.
- Conforms to requirements of EC Council directives relating to Electromagnetic Compatibility and Electrical Safety: 2006/95/CE (LVD), 2004/108/CE (EMC), EN 60335-2-80
- CE marked
- **SAP Q eligible**

- Incoming fresh air
- Warmed fresh air
- Extracted warm, moist, stale air
- Cooled outgoing stale air
- WHHR Mini DC

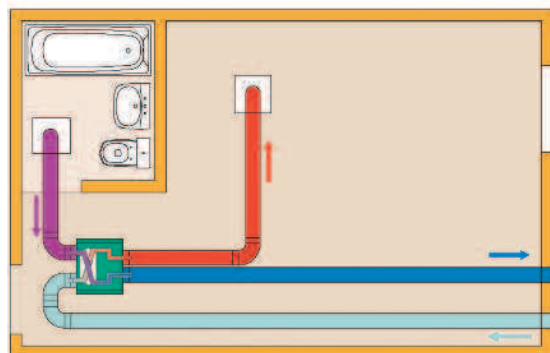

CONTROL FEATURES

Standard

- > **variable adjustment** - trickle and boost speeds set at installation for both motors independently
 - > **boost setting** - with integral overrun timer adjustable up to 20 minutes
 - > **optional delay-on-timer** - boost speed does not operate if switched off within 2 minutes (adjustable from 0-20 mins)
 - > **integral frost-stat** - proportionally reduces intake motor speed as temperature falls
 - > **water level sensor** - shows if condensate exit is blocked and stops unit
- ### Factory Set Options
- > **change of ductwork handing**
 - > **purge boost** - for rapid air change
 - > **BMS connections** - for remote motor shut off
 - > **integral humidistat** - proportionally increases motor speeds with rising humidity
 - > **summer bypass** - automatic bypass of heat exchanger

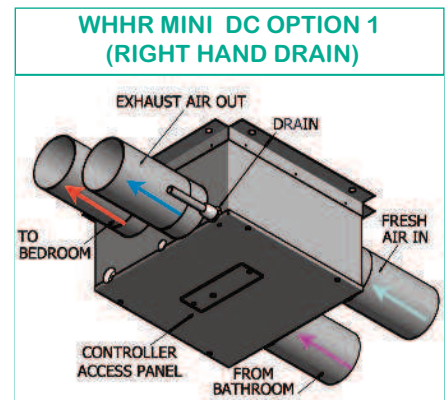
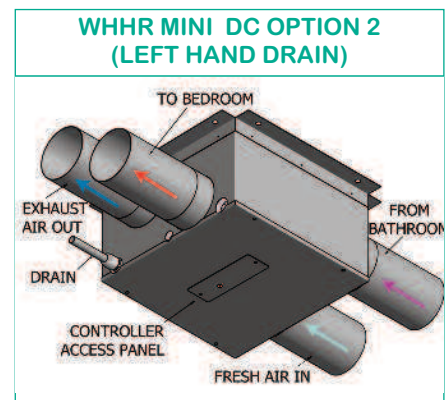



WHHR Mini DC

TECHNICAL CHARACTERISTICS										
Model	Airflow l/sec					Power - Watts				
	maxboost	max trickle	80%	60%	40%	max boost	max trickle	80%	60%	40%
WHHR Mini DC	34	32	28	18	12	80	68	46	24	15

RESULTS for SAP CALCULATIONS			
ENERGY LEVEL PERFORMANCE - using rigid ducting only			
Exhaust Terminal Configuration	Specific Fan Power (W/l/s)	Heat Exchange Efficiency	Airflow Rate (l/sec)
Kitchen + 1 additional wet room	1.11	83 %	15.0
Kitchen + 2 additional wet rooms	1.4	82 %	21.0

Figures from BRE test results at minimum flow rate conditions

WHHR Mini DC		Sound Power Levels, L_w (dB) - Octave Bands Frequency Hz.								Sound Pressure dBA @3m
Curve Ref		63	125	250	500	1k	2k	4k	8k	
Max Boost (34 l/sec)	Extract	65	58	61	63	55	46	36	27	37
	Supply	66	64	70	73	67	64	55	45	
	Breakout	73	59	62	58	49	35	32	24	
Max Trickle (32 l/sec)	Extract	64	56	60	62	54	45	35	26	36
	Supply	65	63	69	72	66	63	54	44	
	Breakout	72	58	61	57	48	34	31	23	
80% (28 l/sec)	Extract	54	54	59	54	45	34	24	22	30
	Supply	55	57	65	62	56	51	42	31	
	Breakout	62	53	57	48	39	31	21	21	
60% (18 l/sec)	Extract	46	50	53	45	37	26	20	21	24
	Supply	50	55	58	48	47	42	33	26	
	Breakout	56	51	50	41	31	23	18	20	
40% (12 l/sec)	Extract	39	46	47	39	29	19	15	21	18
	Supply	45	54	51	47	39	34	23	21	
	Breakout	49	49	44	34	23	16	16	20	

TYPICAL SPECIFICATION

Supply and install a Vectaire WHHR Mini DC energy efficient MVHR as manufactured by Vectaire Ltd, Lincoln Road, Cressex Business Park, High Wycombe, Bucks, HP12 3RH. The unit is to give low level, continuous ventilation to a kitchen and one other wet room. The unit should be for loft or void installation and recover up to 83% of heat from extracted air separating the airflows using a counter flow heat exchanger. The unit should incorporate a low energy EC motor with sealed for life bearings for low noise levels and low energy consumption, and have as standard: variable adjustment; boost setting with integral overrun timer; optional delay-on timer; integral frost-stat; and a water level sensor. It should also have the facility for: change of ductwork handling; purge boost; BMS connections; integral proportional dynamic humidistat; and an automatic summer bypass. The unit should be capable of being fitted to 125mm dia ducting without the need for adaptors, have EPS lining for low noise levels and low heat loss. The unit should comply with Part L1 2013 and Part F 2013 of Building Regulations, be EU RoHS Directive Compliant, conform to the requirements of EC Council directives relating to Electromagnetic Compatibility and Electrical Safety: 2006/95/CE (LVD), 2004/108/CE (EMC), EN 60335-2-80, be CE marked and SAP Q Eligible

Vectaire Ltd can supply all accessories for use with these units, including air filter cassettes, silencers, fire ampers, air valves, ducting, outside grilles and wall cowls. Additionally, Vectaire offers a design service to ensure that the unit installed is the best possible to provide efficient, effective, low energy and low running cost ventilation. Vectaire can also organise installation, commissioning and maintenance of these products

WHHR Mini DC



PERFORMANCE (curves are for guidance only)

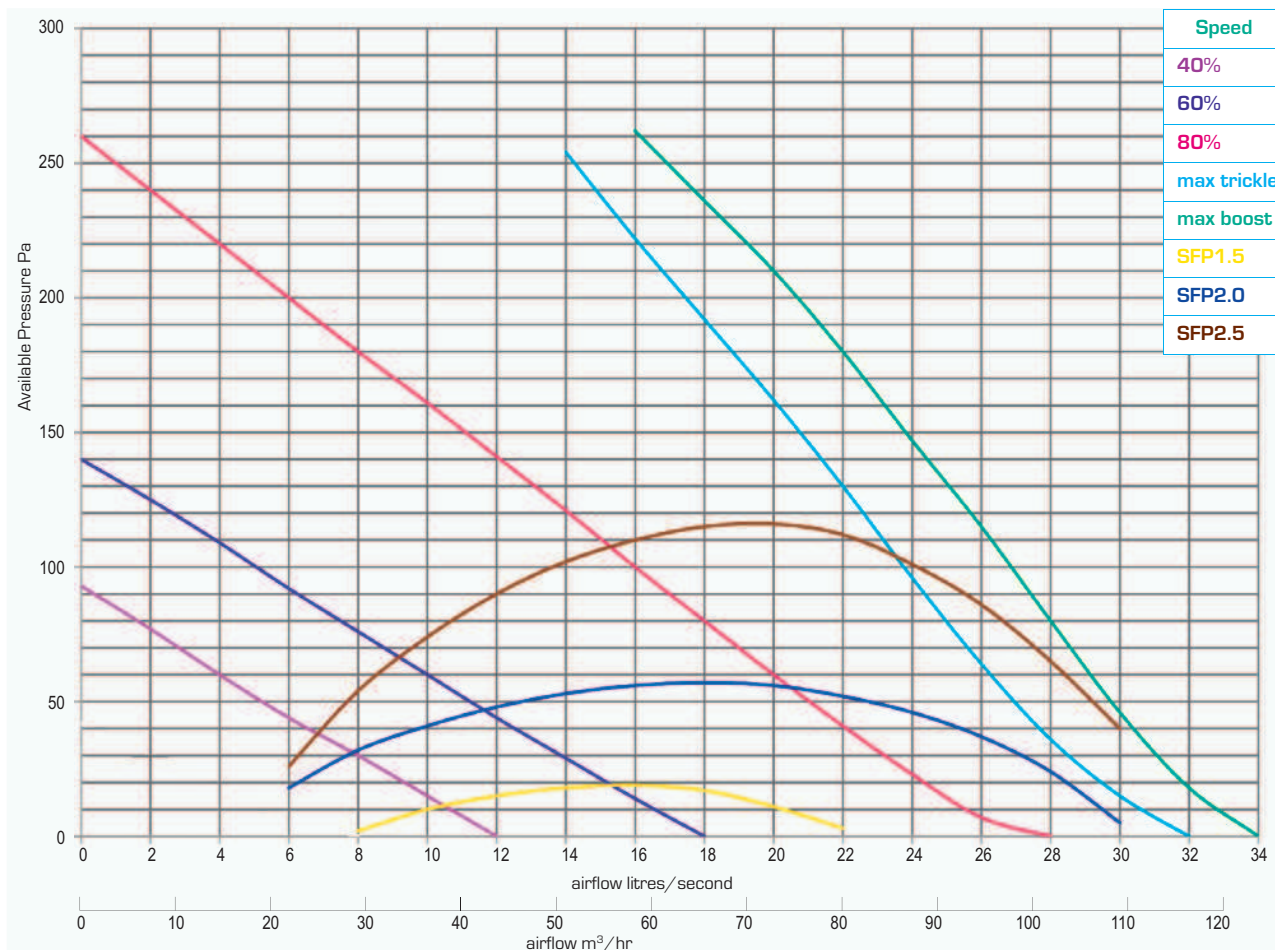

DIMENSIONS - mm (bottom access only)

