

Zest Iris Duct Dampers



- Easily readable built in scale.
- Differential pressure measuring facility.
- Comprehensive size range.
- 100% open position allows for easy cleaning.
- Accurate volume control.

Introduction

The Zest Iris Duct Damper is an ideal air flow regulator and measuring device for circular ducts. Accurate control, smooth and quiet air flow and reliable measuring results are achieved by the special iris construction.

An easily readable scale assists quick and simple adjustment. In the fully open position the Iris Damper provides 100% free area with no control mechanism in the airstream allowing easy and effective cleaning of the ductwork system.

Use as a control damper

The reducing orifice arrangement maintains a uniform airflow over the cross section of the duct.

Closure of the iris produces an accurate throttling of air volume with an even air flow pattern, resulting in low noise levels.

Use as a measuring device

The Zest Iris Duct Damper can be used for measuring air flow rates by means of the orifice plate principle. The accurate control mechanism guarantees exact opening dimensions corresponding to the adjustment scale. Each damper is provided with manometer connections for measuring the differential pressure which then can be directly used to determine the air flow from the measurement scale on the damper casing. The result of the regulation is thus immediately available and any subsequent checks can be carried out very quickly.

Air tightness

The Zest Iris Duct Damper has a 'through the case' air tightness which meets the requirements of the Eurovent Class B.

Temperature

The Zest Iris Duct Damper is suitable for continuous use from - 10°C up to +80°C (if there is moisture in the air the damper may freeze but will not be damaged in this condition unless operated whilst frozen).

Installation

For the best results the Zest Iris Duct Damper should be installed in straight runs of ductwork. The damper may be fixed to ducting with rivets or self-tapping screws. We recommend joints are sealed with Tectape XT or Tecseal sealant to ensure an airtight connection. Flexible ducting may be fixed to the damper using Tecfix banding or clips.

Size range

The Zest Iris Duct Damper is available in a comprehensive range of sizes from 100mm to 400mm.

Construction

The Zest Iris Duct Damper is manufactured from galvanised steel sheet and equipped with an adjustment scale and measuring connections. The tamper proof control knob is adjusted with the spanner provided. Spigots are fitted as standard with rubber gaskets.

Dimensional data

Size 100 ... 400

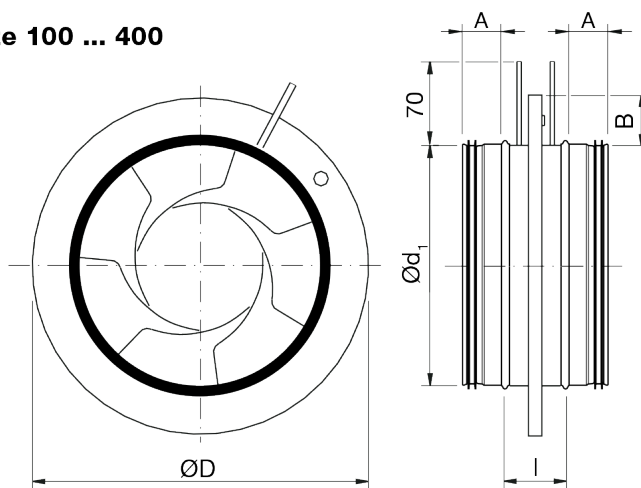

Ød_1 nom	Ød_1 mm	ØD mm	l mm	A mm	B (mm)
100	99	165	110	30	32
125	124	210	110	30	42
150	149	230	120	30	35
160	159	230	110	30	35
200	199	285	110	30	42
250	249	335	135	40	42
300	299	410	140	35	42
315	314	410	135	40	47
400	398	525	190	60	62

Measuring

The balancing graphs show the flow, q_v (l/s), as a function of the measured differential pressure, Δp_m (Pa).

$$q_v = k \cdot \sqrt{\Delta p_m}$$

The formula is only accurate for air with the density 1,2 kg/m³. For air with other density, (ρ_{other}) the flow, (q_{other}), is given according to the formula.

$$q_{other} = q_v \times \sqrt{\frac{1,2}{\rho_{other}}}$$

Measurement accuracy

The required straight distance after or before any disturbance to airflow, as detailed on the card attached to the damper must be observed to obtain accurate flow measurement.

If the velocity profile is asymmetric, the measurement values can differ from the ideal values. For this reason, Zest Iris Duct Dampers should never be located close to any flow disturbance. The measuring accuracy in the table below can vary greatly if these minimum distances are not observed.

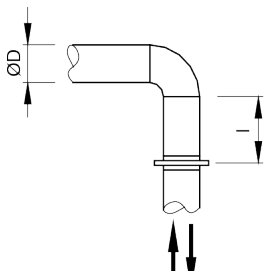
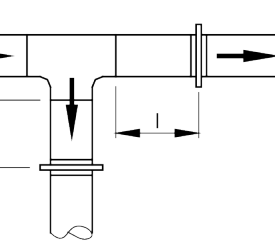
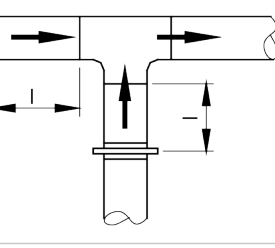
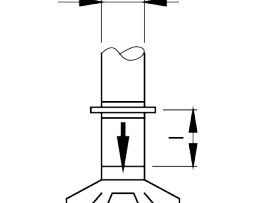
l = straight distances before and after disturbances	Accuracy $\pm 10\%$
	$l \geq 1 D$
	$l \geq 2 D$
	$l \geq 2 D$
	$l \geq 2 D$

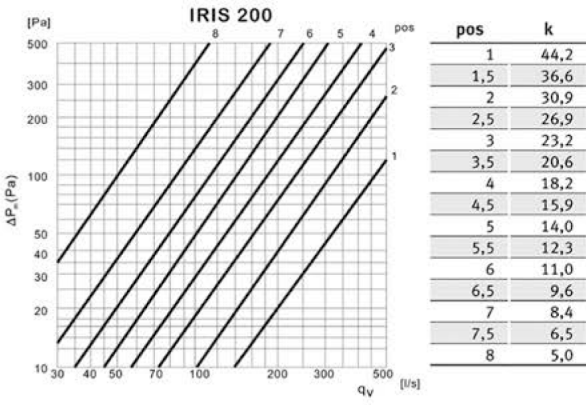
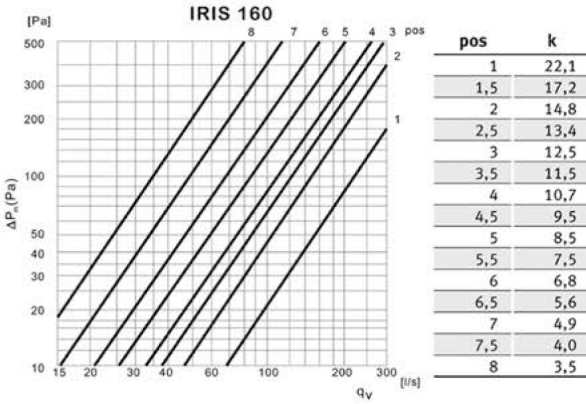
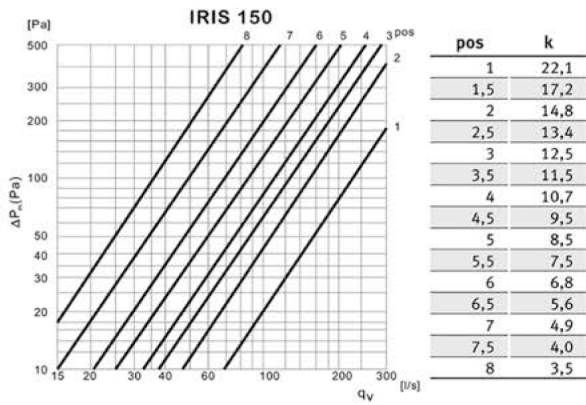
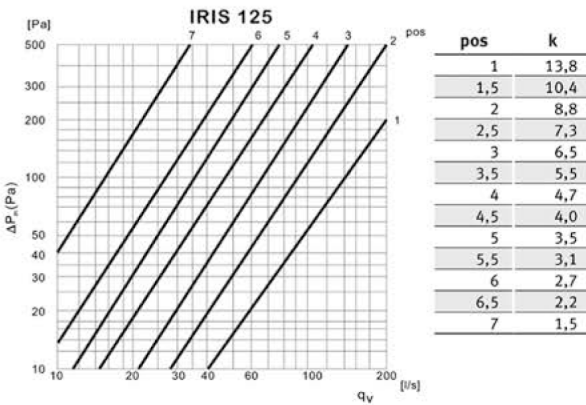
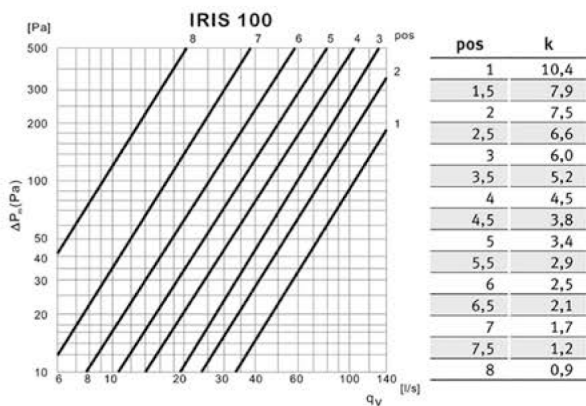

Sound characteristics

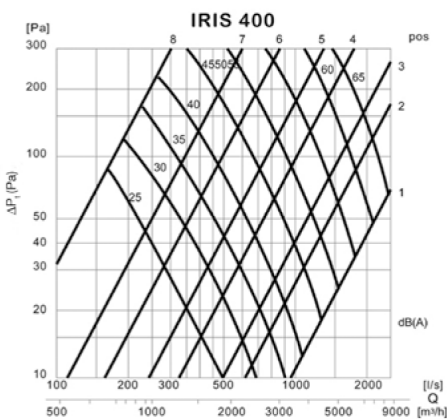
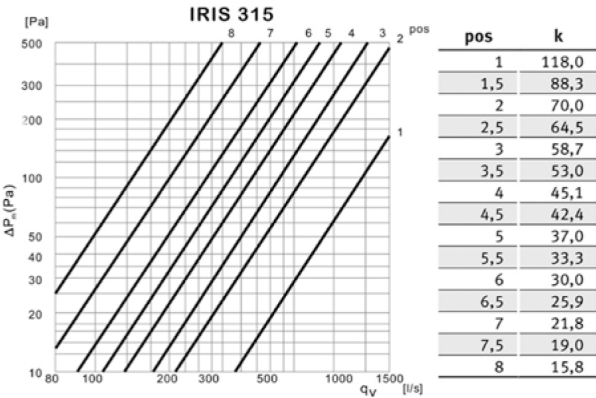
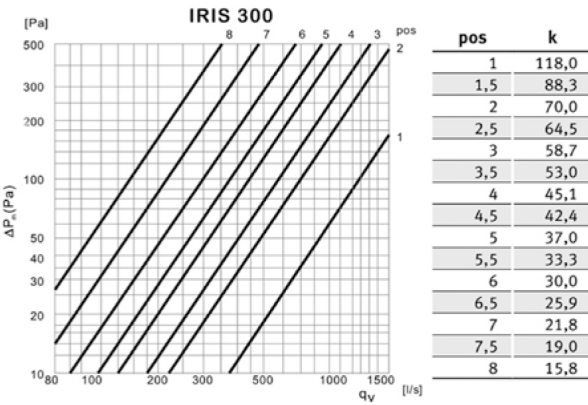
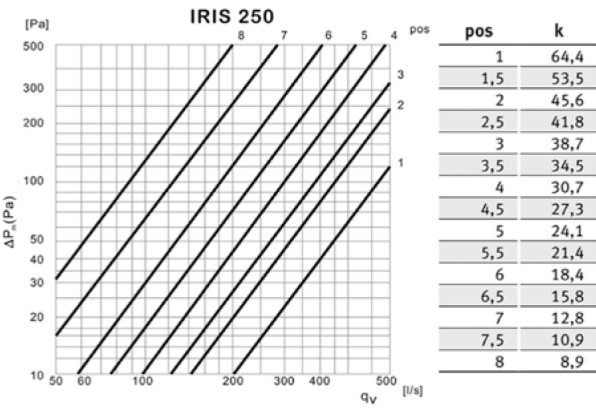

CORRECTION K_{Ooct} (dB)								
IRIS	Middle frequency by octave band (Hz)							
	63	125	250	500	1000	2000	4000	8000
100	25	21	16	9	4	-6	-12	-25
125	17	17	13	7	1	-4	-6	-17
150	21	20	14	8	0	-6	-16	-29
160	19	18	14	6	-1	-6	-13	-25
200	20	17	12	5	-2	-5	14	-26
250	16	12	8	3	1	-4	-17	-32
315	24	12	5	0	1	-2	-13	-27
400	15	9	6	2	-1	-4	-9	-13
Tol.	+6	3	2	2	2	2	2	3

The sound power levels of the duct for each octave band are obtained by adding the corrections K_{Ooct} of octave bands (see table) to the total sound pressure level L_{p10A} dB(A) according to the following formula:

$$L_{\text{woct}} = L_{p10A} + K_{\text{Ooct}}$$

Correction K_{Ooct} is the average in the range of use of the IRIS regulation and measuring device.