

Fitting Instructions

Rytons LookRyt® AirCore®



NOTE: Screws to fix the internal panel are supplied. Screws to fix the external components are not included. Choose screws and fixings suitable for your external surface.

TIP: DO NOT clip the internal LookRyt® face plate to the backplate until the backplate is fixed to the wall.

Tube

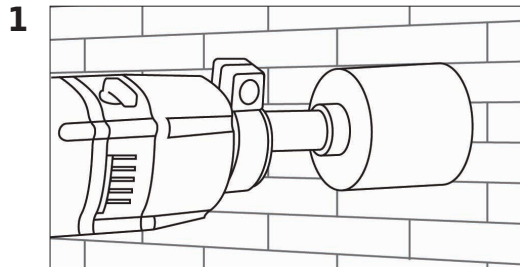

For Rytons 127mm (5") LookRyt® AirCore® range use a 127mm dia. core drill.

For Rytons Mini LookRyt® AirCore® use a 78mm dia. core drill.

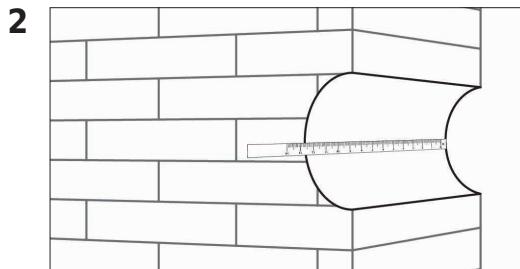

3

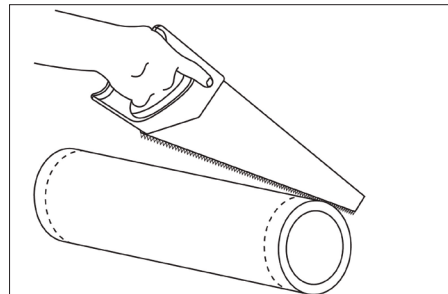

TIP: Cut each end of the tube equally to keep the external water baffle in the centre of the tube.

NOTE: A maximum reduction of 63mm may be cut from each end of a tube containing internal baffles.

TIP: Should cracks occur on the inside after drilling a 127mm dia. hole they can be covered quickly and easily with a Rytons Self-adhesive Wall Plate (code SA5PLATE). Call our sales office to order.

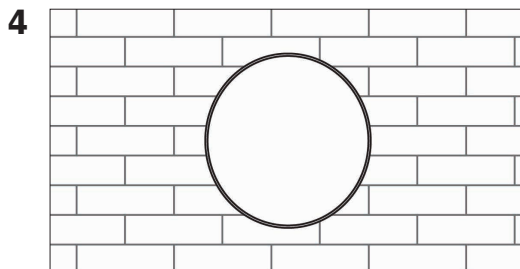

External Grille

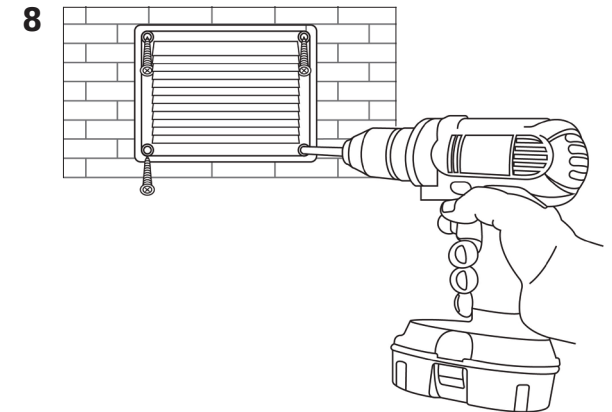
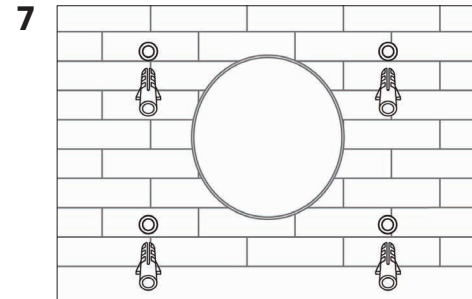
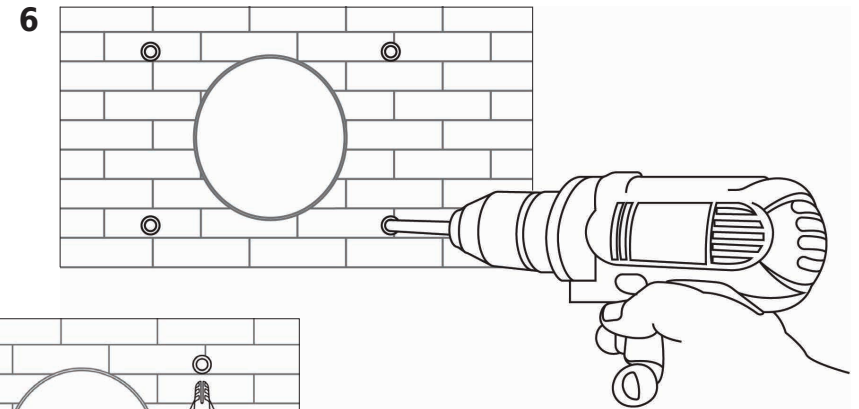
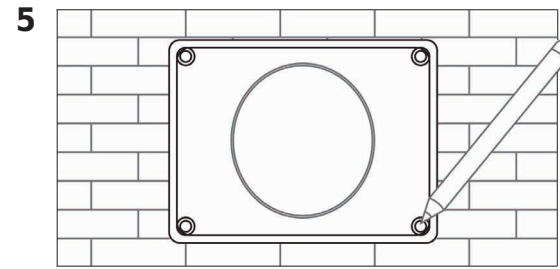

High Rise Models

Mastic around the top ring of the circular external grille and fit into the tube. Ensure the groove in the grille is aligned with the lug inside the tube. Insert the grille and tube assembly into the hole from inside the property.

External Cowl (*if supplied)

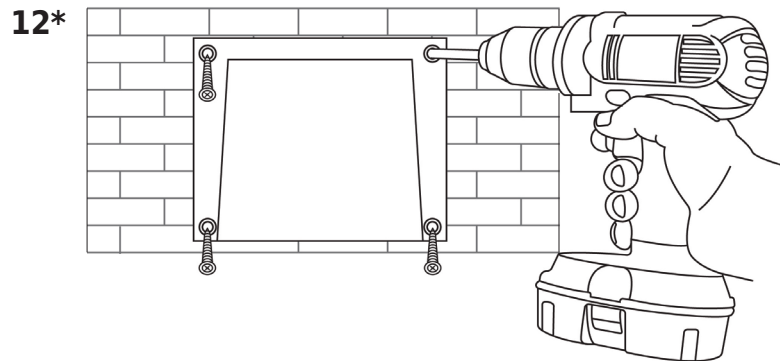
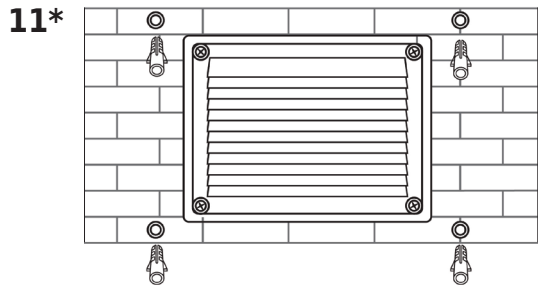
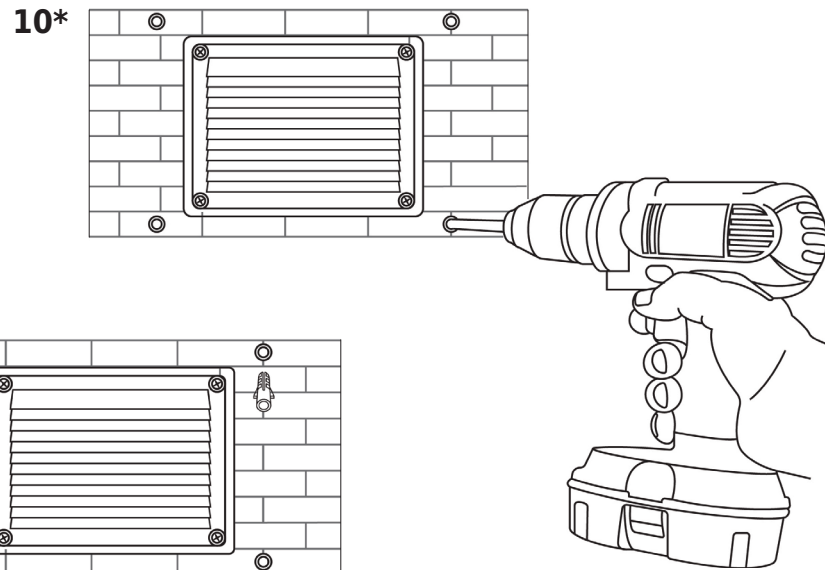
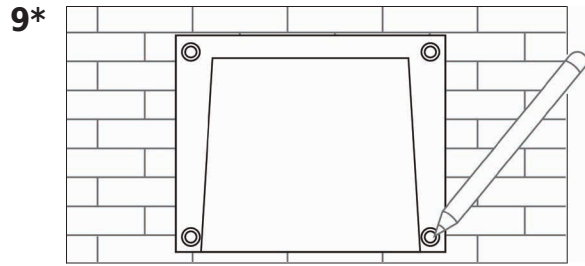

Internal LookRyt® Panel

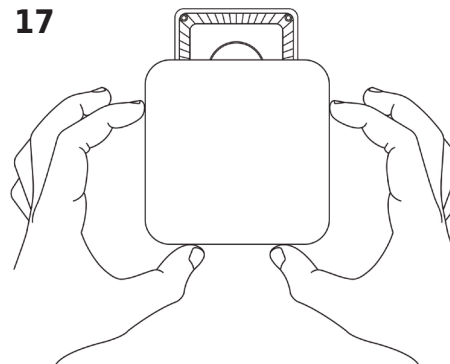
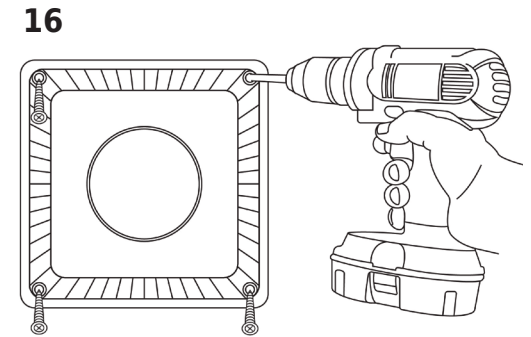
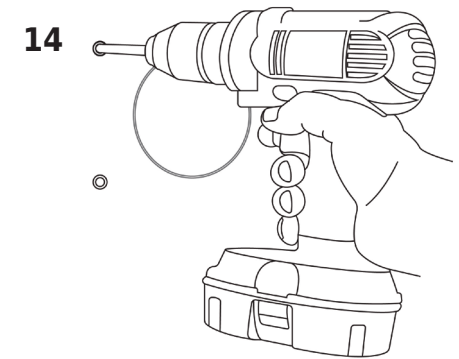
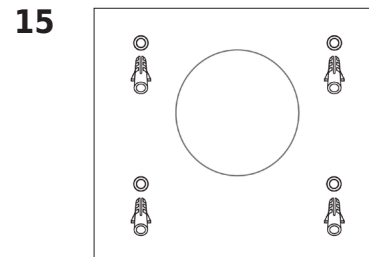
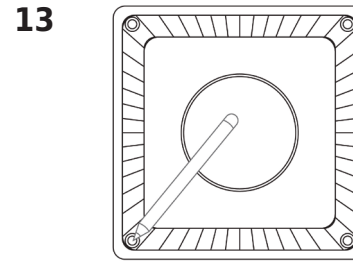

TIP: The LookRyt® face plate may be painted or wallpapered to match the room décor.

18(i)

Controllable model operated by a simple push/pull or tilt action of the flat face plate.

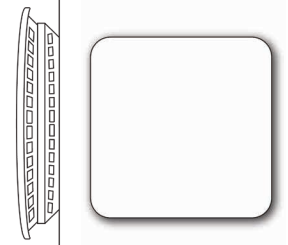

18(ii)

Fixed open model for the provision of combustion air to boilers, stoves and fires.

